



**IL&FS** | Environment

# TECHNICAL EIA GUIDANCE MANUAL FOR DISTILLERIES

Prepared for  
**The Ministry of Environment and Forests**  
Government of India



by  
**IL&FS Ecosmart Limited**  
Hyderabad

August 2010



## PROJECT TEAM

<b>Project Coordination</b>	<b>Dr. Nalini Bhat</b>
<b>Ministry of Environment &amp; Forests</b>	Advisor, Ministry of Environment and Forests
	<b>Dr. T. Chandni</b>
	Director, Ministry of Environment and Forests
<b>Core Project Coordination Team</b>	<b>Mr. Mahesh Babu</b>
<b>IL&amp;FS Environment</b>	CEO
	<b>Mr. N. Sateesh Babu</b>
	Vice President & Project Director
	<b>Dr. A. L. Aggarwal</b>
	Senior Project Consultant
	<b>Mr. B.S.V. Pavan Gopal</b>
	Manager –Technical
	<b>Ms. Tamil Ezhil .G</b>
	Environmental Planner
	<b>Ms. Suman Benedicta Thomas</b>
	Technical Writer
<b>Resource Person</b>	<b>Prof. B. Subba Rao</b>
	President, Environmental Protection Research Foundation and International School of Environmental Management Studies
<b>Expert Core &amp; Peer Committee</b>	
<b>Chairman</b>	<b>Dr. V. Rajagopalan, IAS</b>
	Additional Secretary
	Ministry of Chemicals & Fertilizers
<b>Core Members</b>	<b>Dr. R. K. Garg</b>
	Former Chairman, EIA Committee, Ministry of Environment and Forests
	<b>Mr. Paritosh C. Tyagi</b>
	Former Chairman, Central Pollution Control Board
	<b>Prof. S.P. Gautam</b>
	Chairman, Central Pollution Control Board
	<b>Dr. Tapan Chakraborti</b>
	Director, National Environmental Engineering Research Institute
	<b>Mr. K. P. Nyati</b>
	Former Head, Environmental Policy, Confederation of Indian Industry
	<b>Dr. G.K. Pandey</b>
	Former Advisor, Ministry of Environment and Forests
	<b>Dr. Nalini Bhat</b>
	Advisor, Ministry of Environment and Forests
	<b>Dr. G.V. Subramaniam</b>
	Advisor, Ministry of Environment and Forests
	<b>Dr. B. Sengupta</b>
	Former Member Secretary, Central Pollution Control Board
	<b>Dr. R. C. Trivedi</b>
	Former Scientist, Central Pollution Control Board
<b>Peer Member</b>	<b>Prof. N.J.Rao</b>
	Director, JAYPEE Institute of Engineering and Technology
<b>Member Convener</b>	<b>Mr. N. Sateesh Babu</b>
	Project Director

# TABLE OF CONTENTS

<b>1. INTRODUCTION TO THE TECHNICAL EIA GUIDANCE MANUALS PROJECT .....</b>	<b>1-1</b>
1.1 Purpose	1-2
1.2 Project Implementation.....	1-4
1.3 Additional Information .....	1-4
<b>2. CONCEPTUAL FACETS OF EIA.....</b>	<b>2-1</b>
2.1 Environment in EIA context .....	2-1
2.2 Pollution Control Strategies.....	2-2
2.3 Tools for Preventive Environmental Management.....	2-2
2.3.1 Tools for assessment and analysis .....	2-3
2.3.2 Tools for action.....	2-5
2.3.3 Tools for communication.....	2-10
2.4 Objectives of EIA .....	2-10
2.5 Types of EIA.....	2-11
2.6 Basic EIA Principles.....	2-12
2.7 Project Cycle.....	2-13
2.8 Environmental Impacts .....	2-13
2.8.1 Direct impacts .....	2-14
2.8.2 Indirect impacts.....	2-14
2.8.3 Cumulative impacts .....	2-15
2.8.4 Induced impacts .....	2-15
2.9 Significance of Impacts.....	2-16
2.9.1 Criteria/methodology to determine the significance of the identified impacts.....	2-17
<b>3. ABOUT DISTILLERIES INCLUDING PROCESS AND POLLUTION CONTROL TECHNOLOGIES.....</b>	<b>3-1</b>
3.1 Introduction.....	3-1
3.1.1 Industrial distillation process – history .....	3-2
3.1.2 Ethanol production– world scenario .....	3-2
3.2 Indian context .....	3-3
3.3 Distilling Processes Based on Raw Materials.....	3-6
3.3.1 Distilled liquor based on cereals .....	3-6
3.3.2 Distilled liquor based on molasses.....	3-7
3.4 Process of Distilleries Based on Molasses.....	3-12
3.4.1 Alcohol .....	3-12
3.4.2 Rectified spirit.....	3-14
3.5 Ethanol.....	3-16
3.5.1 Cellulosic ethanol .....	3-17
3.5.2 Grades of ethanol .....	3-17
3.5.3 Sequence of steps for production of ethanol.....	3-18
3.6 Raw Material Inputs in the Production Line.....	3-21

3.7	Industrial Processes of Various Products of Distillery Industry .....	3-23
3.7.1	Manufacturing process of spirits (whisky, vodka & gin).....	3-23
3.7.2	Gin manufacturing process .....	3-28
3.7.3	Vodka manufacturing process.....	3-29
3.7.4	Brandy manufacturing process .....	3-29
3.7.5	Beer production processes .....	3-29
3.7.6	Wine manufacturing process.....	3-31
3.8	In Plant Practices .....	3-32
3.9	Emissions from Distillery Industry .....	3-33
3.9.1	Emissions from beer & wine industries .....	3-33
3.10	In plant Pollution Control in Distilleries.....	3-36
3.10.1	Fermenter sludge.....	3-37
3.10.2	Spent wash .....	3-38
3.11	Classification of Distilleries for Wastewater Treatment Methods.....	3-39
3.11.1	Treatment schemes .....	3-40
3.12	Summary of Applicable National Regulations .....	3-40
3.12.1	General description of major statutes .....	3-40
3.12.2	General standards for discharge of environmental pollutants.....	3-40
<b>4.</b>	<b>OPERATIONAL ASPECTS OF EIA.....</b>	<b>4-1</b>
4.1	Coverage of Distillery Industry Under the Purview of Notification.....	4-1
4.2	Screening .....	4-5
4.2.1	Applicable conditions for Category B projects.....	4-5
4.2.2	Criteria for classification of Category B1 and B2 projects .....	4-5
4.2.3	Application for prior environmental clearance .....	4-6
4.2.4	Siting guidelines .....	4-6
4.3	Scoping for EIA Studies .....	4-7
4.3.1	Pre-feasibility report .....	4-9
4.3.2	Guidance for Filling Information in Form 1 .....	4-10
4.3.3	Identification of appropriate valued environmental components.....	4-10
4.3.4	Methods for identification of impacts.....	4-10
4.3.5	Testing the Significance of impacts.....	4-16
4.3.6	Terms of reference for EIA studies.....	4-16
4.4	Environmental Impact Assessment.....	4-20
4.4.1	EIA team.....	4-21
4.4.2	Baseline quality of the environment .....	4-22
4.4.3	Impact prediction tools .....	4-25
4.4.4	Significance of the impacts.....	4-25
4.5	Social Impact Assessment.....	4-26
4.6	Risk Assessment .....	4-28
4.6.1	Disaster management plan .....	4-32
4.7	Mitigation Measures .....	4-35
4.7.1	Important considerations for mitigation methods .....	4-35
4.7.2	Hierarchy of elements of mitigation plan .....	4-37
4.7.3	Typical mitigation measures .....	4-38
4.8	Environmental Management Plan.....	4-40
4.9	Reporting .....	4-42

**Table of Contents**

4.10 Public Consultation .....	4-43
4.11 Appraisal .....	4-46
4.12 Decision-making .....	4-48
4.13 Post-clearance Monitoring Protocol .....	4-49
<b>5. STAKEHOLDERS' ROLES AND RESPONSIBILITIES .....</b>	<b>5-1</b>
5.1 SEIAA 5-4	
5.2 EAC and SEAC .....	5-7

## LIST OF TABLES

Table 3-1: Capacity of Fermentation Vessels in Distilleries .....	3-7
Table 3-2: Process & Non-Process Application of Water for Molasses Based Distilleries.....	3-8
Table 3-3: Material Balance for One kL of Rectified Spirit (Batch process) .....	3-9
Table 3-4: Process Stream Discharge from Distilleries Based on Molasses.....	3-10
Table 3-5: Characteristics of Spent Wash.....	3-10
Table 3-6: Important Components of Dried Fermenter’s Sludge .....	3-11
Table 3-7: Quantity and Characteristics of Process Wastewater .....	3-11
Table 3-8: Characteristics of Spent Wash from Various Types of Manufacturing Process.....	3-13
Table 3-9: Characteristics of Spent Lees .....	3-14
Table 3-10: Benchmark for Energy Consumption.....	3-22
Table 3-11: Potential Sources of Contaminants in Brewing Operation .....	3-33
Table 3-12 Possible Emissions from Beer and Wine Industries .....	3-34
Table 3-13: Classification of Distilleries based on Capacity .....	3-39
Table 3-14: Total Effluent Volume Proposed for Treatment.....	3-40
Table 3-15: Standards for Wastewater Discharges from Distilleries.....	3-41
Table 4-1: Advantages and Disadvantages of Impact Identification Methods .....	4-11
Table 4-2: Matrix of Impacts .....	4-13
Table 4-3: List of Important Physical Environment Components and Indicators of EBM.....	4-23
Table 4-4: Guidance for Accidental Risk Assessment.....	4-30
Table 4-5: Typical Mitigation Measures.....	4-39

**Acronyms**

Table 5-1: Roles and Responsibilities of Stakeholders Involved in Prior Environmental Clearance 5-1

Table 5-2: Organization-Specific Functions ..... 5-3

Table 5-3: SEIAA: Eligibility Criteria for Chairperson / Members / Secretary ..... 5-5

Table 5-4: EAC/SEAC: Eligibility Criteria for Chairperson / Members / Secretary ..... 5-9

## LIST OF FIGURES

Figure 2-1: Inclusive Components of Sustainable Development.....	2-1
Figure 2-2: Types of Impacts.....	2-14
Figure 2-3: Cumulative Impact.....	2-15
Figure 3-1: Global Per capita Consumption (Unweighed) till 2001 .....	3-3
Figure 3-2: Water Balance for a Distillery - Model Case .....	3-12
Figure 3-3: Process Block Diagram of Distillery (Molasses Based) .....	3-15
Figure 3-4: Block Flow Diagram of Ethanol Plant.....	3-18
Figure 3-5: Preliminary Process Flow Sheet Depicting Fermentation of Molasses .....	3-19
Figure 3-6: Process Flow Sheet Depicting Distillation of Ethanol.....	3-19
Figure 3-7: Process Flow Sheet Depicting Azeotropic Distillation Process.....	3-20
Figure 3-8: Process Flow Sheet Depicting Molecular Seive Dehydration Process .....	3-20
Figure 3-9: Mechanism of Whisky Aging Process .....	3-26
Figure 3-10: Process Flow Sheet Depicting Whisky Production.....	3-28
Figure 3-11: Process Flow Sheet Depicting Wine Production.....	3-31
Figure 4-1: Prior Environmental Clearance Process for Activities Falling Under Category A .....	4-3
Figure 4-2: Prior Environmental Clearance Process for Activities Falling Under Category B .....	4-4
Figure 4-3: Approach for EIA Study .....	4-21
Figure 4-4: Risk Assessment – Conceptual Framework.....	4-30
Figure 4-5: Comprehensive Risk Assessment - At a Glance .....	4-31
Figure 4-6: Hierarchy of Elements of Mitigation Plan .....	4-37



# ANNEXURES

## **Annexure I**

Manufacturing Process of Rectified Spirit Based on Molasses (Biostil Process)

## **Annexure II**

A Compilation of Legal Instruments

## **Annexure III**

General standards for Discharge of Environmental Pollutants as per CPCB

## **Annexure IV**

Form 1 (Application Form for Obtaining EIA Clearance)

## **Annexure V**

Critically Polluted Industrial Areas and Clusters/Potential Impact Zone

## **Annexure VI**

Pre-feasibility Report: Additional Points for Possible Coverage

## **Annexure VII**

Types of Monitoring and Network Design Considerations

## **Annexure VIII**

Guidance for Assessment of Baseline Components and Attributes

## **Annexure IX**

Sources of Secondary Data

## **Annexure X**

Impact Prediction Tools

## **Annexure XI**

Form through which the State Governments/Administration of the Union Territories Submit Nominations for SEIAA and SEAC for the Consideration and Notification by the Central Government

**Annexure XII**

Composition of EAC/SEAC

**Annexure XIII**

Best Practices & Latest Technologies available and reference

## ACRONYMS

AAQ	Ambient Air Quality
ABV	Alcohol by Volume
ADB	Asian Development Bank
APHA	American Public Health Association
BIS	Bureau of Indian Standards
BOD	Biological Oxygen Demand
BOQ	Bill of Quantities
BOT	Build Operate Transfer
CAGR	Compound Average Growth Rate
CCA	Conventional Cost Accounting
CDS	Condensed Distiller Solubles
CER	Corporate Environmental Reports
CFE	Consent for Establishment
CHP	Combined Heat and Power
CO <sub>2</sub>	Carbon Dioxide
COD	Chemical Oxygen Demand
CP	Cleaner Production
CPCB	Central Pollution Control Board
CRZ	Coastal Regulatory Zone
CSR	Corporate Social Responsibility
DDG	Distiller Dried Grains
DDS	Distiller Dried Solubles
DO	Dissolved Oxygen
EAC	Expert Appraisal Committee
EBM	Environmental Baseline Monitoring
EcE	Economic-cum-Environmental
ECI	Environmental Condition Indicators
EFI	Electronic Fuel Injection
EIA	Environmental Impact Assessment
EPI	Environmental Performance Indicators
EMS	Environmental Management System
ETP	Effluent Treatment Plant
FCA	Full Cost assessment

GIS	Geographical Information Systems
HAP	Hazardous Air Pollutant
HTL	High Tide Line
IL&FS	Infrastructure Leasing and Financial Services
IMFL	Indian Made Foreign Liquor
kL	Kilolitre
km	kilometre
l	litres
LCA	Life Cycle Assessment
LDAR	Leak Detection and Repair
MoEF	Ministry of Environment & Forests
$\mu\text{g}/\text{m}^3$	milligrams per cubic meter
MT	Metric Tonne
PSA	Pressure Swing Adsorption
QRA	Quantitative Risk Assessment
R&D	Research and Development
R&R	Resettlement and Rehabilitation
RSPM	Respirable Suspended Particulate Matter
RS	Rectified Spirit
SEAC	State Level Expert Appraisal Committee
SEIAA	State Level Environment Impact Assessment Authority
SEZ	Special Economic Zone
SO <sub>2</sub>	Sulphur Dioxide
SO <sub>4</sub>	Sulphate
SWI	Specific Water Intake
TCA	Total Cost Assessment
TDS	Total Dissolved Solids
TEQM	Total Environmental Quality Movement
TGM	Technical EIA Guidance Manual
TSS	Total Suspended Solids
UNEP	United Nations Environment Programme
UT	Union Territories
UTEIAA	Union Territory Level Environment Impact Assessment Authority
VOC	Volatile Organic Compound
VEC	Valued Environmental Components
WBCSD	World Business Council on Sustainable Development

**Mahesh Babu**  
*Chief Executive Officer*

### Acknowledgement

The Notification issued on the prior environmental clearance process by the Ministry of Environment and Forests (MoEF) on September 14, 2006 delegated substantial powers to the State Level Environment Impact Assessment Authorities (SEIAA) to grant environmental clearance for certain categories of developmental activities/projects. It was felt that proper guidance to the stakeholders would enhance appreciation of environmental impacts of proposed projects and possible mitigation measures. Further, such a guidance would also help ensure that decision making authorities across different States and Union Territories could adopt similar considerations and norms with due weightage for site-specific considerations.

We feel privileged to be part of the interventions being spearheaded by Sh. Jairam Ramesh, Hon'ble Minister, MoEF, Government of India, to mainstream environmental considerations in the decision making process. IL&FS Ecosmart as part of this important initiative, prepared Technical EIA Guidance Manuals for 27 identified development activities. In view of the diversity of 27 developmental activities entrusted to IL&FS Ecosmart Ltd., in consultation with the MoEF, an expert Peer and Core Committee was constituted to review and finalize each of the draft Manuals. The Manuals prepared by IL&FS were technically reviewed and up-dated by the respective sector-specific expert resource persons.

The Manuals designed by the Expert Committee have benefitted from the advise and feedback received from MoEF. The Manuals are designed to provide readers with an in-depth understanding of the environmental clearance mechanism, developmental activity specific environmental impacts with possible mitigation measures, environmentally compliant manufacturing/ production processes and pollution control technologies, etc.

IL&FS Ecosmart hopes that these Manuals are a step forward to realize the MoEF's desired objective of enhancing functional efficiency and effectiveness in the environmental clearance process. We hope the stakeholders will find the Manuals useful.

We take this opportunity to convey our appreciation to the MoEF team under the leadership of Mr. J.M. Mauskar, Additional Secretary, for the technical inputs, guidance and support extended throughout the project period for successful completion of the project. The technical guidance and support extended by the Expert Peer and Core Committee under the Chairmanship of Dr. V. Rajagopalan, former Chairman, Central Pollution Control Board and inputs of the sector-specific resource persons are gratefully acknowledged.

  
(Mahesh Babu)

15<sup>th</sup> November 2010



22<sup>nd</sup> December 2010

## FOREWORD

The Ministry of Environment & Forests (MOEF) introduced the Environmental Impact Assessment (EIA) Notification 2006 on 14<sup>th</sup> September 2006, which not only reengineered the entire environment clearance (EC) process specified under the EIA Notification 1994, but also introduced a number of new developmental sectors which would require prior environmental clearance. The EIA Notification 2006 has notified a list of 39 developmental sectors which have been further categorised as A or B based on their capacity and likely environmental impacts. Category B projects have been further categorised as B1 and B2. The EIA Notification 2006 has further introduced a system of screening, scoping and appraisal and for the setting up of Environment Impact Assessment Authority (EIAA) at the Central level and State Level Environment Impact Assessment Authorities (SEIAAs) to grant environmental clearances at the Central and State level respectively. The Ministry of Environment & Forests is the Environment Impact Assessment Authority at the Central level and 25 State Level Environment Impact Assessment Authorities (SEIAAS) have been set up in the various States/UTs. The EIA Notification 2006 also stipulates the constitution of a multi-disciplinary Expert Appraisal Committee (EAC) at the Centre and State level Expert Appraisal Committees (SEACs) at State/UT Level for appraisal of Category A or B projects respectively and to recommend grant/rejection of environmental clearance to each project/activities falling under the various sectors to the EIAA/SEIAAs respectively.

Although the process of obtaining environmental clearance consisting of Screening, Scoping and Appraisal and for undertaking public consultation including the process of conduct of Public Hearing has been elaborated under the EIA Notification 2006, the Notification itself provides for bringing out guidelines from time to time on the EIA Notification 2006 and the EC process with a view to bringing clarity on the EC process for expediting environmental clearance. This need was further reinforced after the constitution of SEIAAs and SEACs in various States, who were assigned the task for the first time and for addressing the concerns of standardization of the quality of appraisal and in reducing inconsistencies between SEACs/SEIAAs in granting ECs for similar projects in different States.

The Technical Guidance Manual of "Distilleries" sector describes types of process and pollution control technologies, operational aspects of EIA with model TOR of that Sector, technological options with cleaner production and waste minimization techniques, monitoring

of environmental quality, post clearance monitoring protocol, related regulations, and procedure of obtaining EC if linked to other clearances for e.g., CRZ, etc.

The main source of pollution from the distillery industry is the spentwash. Generally, biomethane followed by bio-composting or construction of spent wash and then incineration are recommended for the treatment of effluent. Standards for treated wastewater discharges from distillation are notified and should be strictly followed. Multi-effect evaporators are generally recommended to control gaseous emissions. India's industrial competitiveness and environmental future depends on Industries such as Distilleries adopting energy and resource efficient technologies. Recycling and reuse of materials is critical.

To keep pace with changing technologies and needs of sustainable development, the manual would require regular updating in the future. The manual will be available on the MoEF website and we would appreciate receiving responses from stakeholders for further improvements.

I congratulate the entire team of IL&FS Ecosmart Ltd., experts from the sector who were involved in the preparation of the Manuals, Chairman and members of the Core and Peer Committees of various sectors and various Resource Persons whose inputs were indeed valuable in the preparation and finalization of the Manuals.



(Jairam Ramesh)

# 1. INTRODUCTION TO THE TECHNICAL EIA GUIDANCE MANUALS PROJECT

Environmental Impact Assessment (EIA) is a process of identifying, predicting, evaluating and mitigating the biophysical, social, and other relevant effects of development proposals prior to major decisions being taken and commitments made. These studies integrate the environmental concerns of developmental activities into the process of decision-making.

EIA has emerged as one of the successful policy innovations of the 20th Century in the process of ensuring sustained development. Today, EIA is formalized as a regulatory tool in more than 100 countries for effectively integration of environmental concerns in the economic development process. The EIA process in India was made mandatory and was also given a legislative status through a Notification issued by the Ministry of Environment and Forests (MoEF) in January 1994. However, the Notification covered only a few selected industrial developmental activities. While there are subsequent amendments, the Notification issued on September 14, 2006 supersedes all the earlier Notifications, and has brought out structural changes in the clearance mechanism.

The basic tenets of this EIA Notification could be summarized into following:

- Pollution potential as the basis for prior environmental clearance instead of investment criteria; and
- Decentralization of clearing powers to the State/Union Territory (UT) level Authorities for certain developmental activities to make the prior environmental clearance process quicker, transparent and effective.

Devolution of the power to grant clearances at the state-level for certain categories of the developmental activities / projects is a step forward to fulfill the basic tenets of the re-engineering *i.e.*, quicker, transparent and effective process but many issues impede/hinder its functional efficiency. These issues could be in technical and operational as listed below:

## Technical Issues

- Ensuring level playing ground to avoid arbitrariness in the decision-making process
- Classification of projects which do not require public hearing and detailed EIA (Category B2)
- Variations in drawing the Terms of Reference (ToR) for EIA studies for a given developmental activity across the States/UTs
- Varying developmental-activity-specific expertise requirement for conducting EIA studies and their appraisal
- Availability of adequate sectoral experts and variations in competency levels
- Inadequate data verification, cross checking tools and supporting institutional framework

- Meeting time targets without compromising with the quality of assessments/ reviews
- Varying knowledge and skill levels of regulators, consultants and experts
- Newly added developmental activities for prior environmental clearance, *etc.*

### **Operational Issues**

- State level /UT level EIA Authorities (SEIAA/UTEIAA) are formulated for the first time and many are functioning
- Varying roles and responsibilities of involved organizations
- Varying supporting institutional strengths across the States/UTs
- Varying manpower availability *etc.*

## **1.1 Purpose**

The purpose of developing the sector-specific technical EIA guidance manuals (TGMs) is to provide clear and concise information on EIA to all the stakeholders *i.e.*, the project proponent, the consultant, the reviewer, and the public. The TGMs are organized to cover following:

**Chapter 1 (Introduction):** This chapter provides a brief introduction on the EIA, basic tenets of EIA Notification, technical & operational issues in the process of clearance, purpose of the TGMs, project implementation process and additional information.

**Chapter 2 (Conceptual facets of an EIA):** This chapter covers the discussion on environment in EIA context *i.e.*, sustainable development, pollution control strategies, preventive environmental management tools, Objectives of EIA, types and basic principles of EIA, project cycle for distilleries, understanding on type of environmental impacts and the criteria for the significance analysis.

**Chapter 3 (Distilleries):** The purpose of this chapter is to provide the reader precise information on all the relevant aspects of the industry, which is essential to realize the likely interaction of such developmental activities on the receiving environment. Besides, this Chapter gives a holistic understanding on the sources of pollution and the opportunities of the source control.

The specific coverage which provides precise information on the industry include (i) Introduction - Industrial distillation process–history, Ethanol production–world scenario, (ii) Indian context, (iii) Distilling processes based on raw materials - distilled liquor based on cereals, distilled liquor based on molasses, (iv) Process of distilleries based on molasses - alcohol, rectified spirit, (v) Ethanol - cellulosic ethanol, grades of ethanol, sequence of steps for production of ethanol, (vi) Raw material inputs in the production line, (vii) Industrial processes of various products of distillery industry - manufacturing process of spirits (whisky, vodka & gin), gin manufacturing process, vodka manufacturing process, brandy manufacturing process, beer production processes, wine manufacturing process, (viii) In plant practices, (ix) Emissions from distillery industry - emissions from beer & wine industries, (x) In plant pollution control in distilleries - fermenter sludge, Spent wash, (xi) Classification of distilleries for wastewater treatment methods - treatment schemes and (xii) Summary of applicable national regulations - general description of major statutes.



**Chapter 4 (Operational aspects):** The purpose of this chapter is to facilitate the stakeholders to extend clear guidance on coverage of legislative requirements, sequence of procedures for obtaining the EIA clearance and each step-wise provisions and considerations.

The coverage of the Chapter include provisions in the EIA Notification regarding distilleries, screening (criteria for categorization of B1 and B2, siting guidelines, *etc.*), scoping (pre-feasibility report, guidance for filling form 1, identification of valued environmental components, identification of impacts, *etc.*), arriving at terms of reference for EIA studies, impact assessment studies (EIA team, assessment of baseline quality of environment, impact prediction tools, significance of impacts), social impact assessment, risk assessment considerations, typical mitigation measures, designing considerations for environmental management plan, structure of EIA report for incorporation of study findings, process of public consultation, project appraisal, decision making process and post-clearance monitoring protocol.

**Chapter 5 (Roles and responsibilities of various organizations involved in the process of prior environmental clearance):** The purpose of this chapter is to brief the stakeholders on the institutional mechanism and roles & responsibilities of the stakeholders involved in the process of prior environmental clearance. The coverage of the chapter include (i) Roles and responsibilities of the stakeholders, (ii) Organization specific functions, (iii) Constitution, composition and decision making process of SEIAA and (iv) EAC & SEAC and (v) Other conditions which may be considered.

For any given industry, each topic listed above could alone be the subject of a lengthy volume. However, in order to produce a manageable document, this project focuses on providing summary information for each topic. This format provides the reader with a synopsis of each issue. Text within each section was researched from many sources, and was condensed from more detailed sources pertaining to specific topics.

The contents of the document are designed with a view to facilitate addressing of the relevant technical and operational issues as mentioned in the earlier section. Besides, facilitates various stakeholders involved in the EIA clearance process *i.e.*

- Project proponents will be fully aware of the procedures, common ToR for EIA studies, timelines, monitoring needs, *etc.*, in order to plan the projects/studies appropriately.
- Consultants across India will gain similar understanding about a given sector, and also the procedure for EIA studies, so that the quality of the EIA reports gets improved and streamlined.
- Reviewers across the States/UTs will have the same understanding about an industrial sector and would able to draw a benchmark to establish the significant impacts for the purpose of prescribing the ToR for EIA studies and also in the process of review and appraisal.
- Public who are concerned about new or expansion projects, use this manual to get a basic idea about the manufacturing/production details, rejects/wastes from the operations, choice of cleaner/ control technologies, regulatory requirements, likely environmental and social concerns, mitigation measures, *etc.*, in order to seek clarifications appropriately in the process of public consultation. The procedural clarity in the document will further strengthen them to understand the stages involved in clearance and roles and responsibilities of various organizations.

- In addition, these manuals would substantially ease the pressure on reviewers at the scoping stage and would bring in functional efficiency at the central and state levels.

## 1.2 Project Implementation

The Ministry of Environment & Forests (MoEF), Government of India took up the task of developing sector-specific TGMs for all the developmental activities listed in the re-engineered EIA Notification. The Infrastructure Leasing and Financial Services Ecosmart Limited (IL&FS Ecosmart), has been entrusted with the task of developing these manuals for 27 industrial and related sectors. Distilleries are one of these sectors, for which this manual is prepared.

The ability to design comprehensive EIA studies for specific industries depends on the knowledge of several interrelated topics. Therefore, it requires expert inputs from multiple dimensions *i.e.*, administrative, project management, technical, scientific, social, economic, risk, *etc.*, in order to comprehensively analyze the issues of concern and to draw logical interpretations. Thus, Ecosmart has designed a well-composed implementation framework to factor inputs of the experts and stakeholders in the process of finalization of these manuals.

The process of manual preparation involved collection & collation of the secondary available information, technical review by sectoral resource persons and critical review and finalization by a competent Expert Committee composed of core and sectoral peer members.

The MoEF appreciates the efforts of Ecosmart, Expert Core and Peer Committee, resource persons and all those who have directly and indirectly contributed to this Manual.

## 1.3 Additional Information

This TGM is brought out by the MoEF to provide clarity to all the stakeholders involved in the 'prior environmental clearance' process. As such, the contents and clarifications given in this document do not withstand in case of a conflict with the statutory provisions of the Notifications and Executive Orders issued by the MoEF from time-to-time.

TGMs are not regulatory documents. Instead, these are the tools designed to assist in successful completion of an EIA. For the purpose of this project, the key elements considered under TGMs are: conceptual aspects of EIA; developmental activity-specific information; operational aspects; and roles and responsibilities of involved stakeholders.

This manual is prepared considering the Notification issued on September 14, 2006 and latest amendment as on 1<sup>st</sup> December, 2009. For recent updates, if any, may please refer the website of the MoEF, Government of India *i.e.*, <http://moef.nic.in/index.php>.

## 2.

# CONCEPTUAL FACETS OF EIA

It is an imperative requirement to understand the basic concepts concerned to the pollution control and the environmental impact assessment in an overall objective of the sustainable development. This chapter highlights the pollution control strategies and their tools besides the objectives, types & principles of EIA, type of impacts their significance analysis, in order to provide consistent understanding to the reader before assessing the development of activity-specific environmental concerns in Chapter 3 and identification & prediction of significant impacts in order to design mitigation measures as detailed in Chapter 4.

### 2.1 Environment in EIA context

‘Environment’ in EIA context mainly focuses, but is not limited to physical, chemical, biological, geological, social, economical, and aesthetic dimensions along with their complex interactions, which affect individuals, communities and ultimately determines their forms, character, relationship, and survival. In EIA context, ‘effect’ and ‘impact’ can often be used interchangeably. However, ‘impact’ is considered as a value judgment of the significance of an effect.

Sustainable development is built on three basic premises *i.e.*, economic growth, ecological balance and social progress. Economic growth achieved in a way that does not consider the environmental concerns, will not be sustainable in the long run. Therefore, sustainable development needs careful integration of environmental, economic, and social needs in order to achieve both an increased standard of living in short-term, and a net gain or equilibrium among human, natural, and economic resources to support future generations in the long-term.

“It is necessary to understand the links between environment and development in order to make choices for development that will be economically efficient, socially equitable and responsible, as well as environmentally sound.” Agenda 21

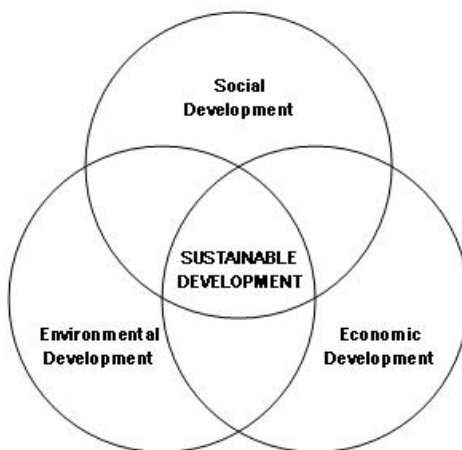

**Figure 2-1: Inclusive Components of Sustainable Development**

## 2.2 Pollution Control Strategies

Pollution control strategies can be broadly categorized in to preventive and reactive. The reactive strategy refers to the steps that may be applied once the wastes are generated or contamination of the receiving environment takes place. The control technology or a combination of technologies to minimize the impact due to the process rejects/wastes varies with quantity and characteristics, desired control efficiency and economics.

Many combinations of techniques could be adopted for treatment of a specific waste or the contaminated receiving environment, but are often judged based on techno-economic feasibility. Therefore, the best alternative is to take all possible steps to avoid pollution itself. This preventive approach refers to a hierarchy that involves i) prevention & reduction; ii) recycling and re-use; iii) treatment; and iv) disposal, respectively.

Therefore, there is a need to shift the emphasis from the reactive to preventive strategy *i.e.*, to promote preventive environmental management. Preventive environmental management tools may be grouped into management based tools, process based tools and product based tools. A few of them are given below:

Management Based Tools	Process Based Tools	Product Based Tools
Environmental Management System (EMS)	Environmental Technology Assessment	Industrial Ecology
Environmental Performance Evaluation	Toxic Use Reduction	Extended Producers Responsibility
Environmental Audits	Best Operating Practices	Eco-labeling
Environmental Reporting and Communication	Environmentally Best Practice	Design for Environment
Total Cost Accounting	Best Available Technology (BAT)	Life Cycle Assessment (LCA)
Law and Policy	Waste Minimization	
Trade and Environment	Pollution Prevention	
Environmental Economics	Cleaner Production	
	4-R Concept	
	Cleaner Technology	
	Eco-efficiency	

## 2.3 Tools for Preventive Environmental Management

The tools preventive environmental management can be broadly classified in to following three groups.

- Tools for assessment and analysis - risk assessment, life cycle assessment, total cost assessment, environmental audit / statement, environmental benchmarking, environmental indicators
- Tools for action - environmental policy, market based economic instruments, innovative funding mechanism, EMS and ISO certification, total environmental quality movement, eco-labeling, cleaner production, eco-efficiency, industrial ecosystem or metabolism, voluntary agreements
- Tools for communication - state of environment, corporate environmental reporting

Specific tools under each group are discussed precisely in next sections.

## 2.3.1 Tools for assessment and analysis

### 2.3.1.1 Risk assessment

Risk is associated with the frequency of failure and consequence effect. Predicting such situations and evaluation of risk is essential to take appropriate preventive measures. The major concern of the assessment is to identify the activities falling in a matrix of high & low frequencies at which the failures occur and the degree of its impact. The high frequency, low impact activities can be managed by regular maintenance *i.e.* LDAR (Leak detection and repair) programmes. Whereas, the low frequency, high impact activities (accidents) are of major concern in terms of risk assessment. As the frequency is low, often the required precautions are not realized or maintained. However, risk assessment identifies the areas of major concerns which require additional preventive measures; likely consequence distances considering domino effects, which will give the possible casualties and ecological loss in case of accidents. These magnitudes demand the attention for preventive and disaster management plans (DMP). Thus is an essential tool to ensure safety of operations

### 2.3.1.2 Life cycle assessment

A broader approach followed to deal with environmental impacts during manufacturing is called LCA. This approach recognizes that environmental concerns are associated with every step of processing w.r.t manufacturing of products and also examines environmental impacts of the product at all stages of project life cycle. LCA includes the product design, development, manufacturing, packaging, distribution, usage and disposal. LCA is concerned with reducing environmental impacts at all stages and considering the total picture rather than just one stage of production process.

Industries/firms may apply this concept to minimize the costs incurred on environmental conservation throughout the project life cycle.

### 2.3.1.3 Total cost assessment

Total Cost Assessment (TCA) is an enhanced financial analysis tool that is used to assess the profitability of alternative courses of action ex. raw material substitution to reduce the costs of managing the wastes generated by process; an energy retrofit to reduce the costs of energy consumption. This is particularly relevant for pollution prevention options. These options, because of their nature, often produce financial savings that are overlooked in conventional financial analysis, either because they are misallocated, uncertain, hard to quantify, or occur more than three to five years after the initial investment. TCA includes all relevant costs and savings associated with an option so that it can compete for scarce capital resources fairly, on a level playing field. The assessments are often beneficial w.r.t the following:

- Identification of costly resource inefficiencies
- Financial analysis of environmental activities/projects such as investment in cleaner technologies
- Prioritization of environmental activities/projects
- Evaluation of product mix and product pricing
- Bench marking against the performance of other processes or against the competitors

A comparison of cost assessments is given below:

- Conventional cost accounting (CCA): Direct and indirect financial costs+ Recognized contingent costs
- Total Cost Assessment (TCA): A broader range of direct, indirect, contingent and less quantifiable costs
- Full Cost assessment (FCA): TCA + External social costs borne by society

#### 2.3.1.4 Environmental audit/statement

Key objectives of an environmental audit include compliance verification, problem identification, environmental impact measurement, environmental performance measurement, conforming effectiveness of EMS, providing a database for corrective actions and future actions, developing company's environmental strategy, communication and formulating environmental policy.

The MoEF, Government of India (GOI) issued Notification on 'Environmental Statements' (ES) in April, 1992 and further amended in April 1993. As per the Notification, the industries are required to submit environmental statements to the respective State Pollution Control Boards (SPCBs). ES is a pro-active tool for self-examination of the industry to reduce/minimize pollution by adopting process modifications, recycling and reusing of the resources. The regular submission of ES will indicate the systematic improvement in environmental pollution control being achieved by the industry. In other way, specific points in ES may be used as environmental performance indicators for relative comparison, implementation and to promote better practices.

#### 2.3.1.5 Environmental benchmarking

Environmental performance and operational indicators could be used to navigate, manage and communicate significant aspects and give enough evidence of good environmental house keeping. Besides the existing prescribed standards, an insight to identify the performance indicators and prescribing schedule for systematic improvement in performance of these indicators will yield better results.

Relative indicators may be identified for different industrial sectors and be integrated in companies and organizations to monitor and manage different environmental aspects of the company, to benchmark and compare two or more companies from the same sector. These could cover water consumption, wastewater generation, energy consumption, solid/hazardous waste generation, chemical consumption *etc.* per tonne of final product. Once these bench marks are developed, the industries which are below the benchmark may be guided and enforced to reach them while those which are better than the benchmark may be encouraged further by giving incentives *etc.*

#### 2.3.1.6 Environmental indicators

Indicators can be classified in to environmental performance indicators (EPI) and environmental condition indicators (ECI). The EPIs can be further divided into two categories *i.e.* operational performance indicators and management performance indicators.

The operational performance indicators are related to the process and other operational activities of the organization. These would typically address the issue of raw material consumption, energy consumption, water consumption in the organization, the quantities

of wastewater generated, other solid wastes & emissions generated from the organization *etc.*

Management performance indicators are related to management efforts to influence environmental performance of organizational operations.

The environmental condition indicators provide information about the environment. These indicators provide information about the local, regional, national or global condition of the environment. This information helps an organization to understand the environmental impacts of its activities and thus help in making decision to improve the environmental performance.

Indicators are basically used to evaluate environmental performance against the set standards and thus indicate the direction in which to proceed. Selection of type of indicators for a firm or project depends upon its relevance, clarity and realistic cost of collection and its development.

## 2.3.2 Tools for action

### 2.3.2.1 Environmental policy

An environmental policy is a statement of an organization's overall aim and principles of action w.r.t the environment, including compliance with all relevant regulatory requirements. It is a key tool in communicating environmental priorities of the organization to all its employees. To ensure organization's commitment towards a formulated environmental policy, it is essential that top management be involved in the process of formulating the policy and setting priorities. Therefore, the first step is to get the commitment from the higher levels of management. The organization should then conduct an initial environmental review and draft an environmental policy. This draft should be discussed and approved by the board of directors. The approved environmental policy statement should then be communicated internally among all its employees and should also be made available to the public.

### 2.3.2.2 Market-based economic instruments

Market based instruments are regulations that encourage behavior through market signals rather than through explicit directives regarding pollution control levels. These policy instruments such as tradable permits, pollution charge, *etc.*, are often described as harnessing market forces. Market-based instruments can be categorized into four major categories, which are discussed below:

- **Pollution charge:** Charge system will assess a fee or tax on the amount of pollution a firm or source generates. It is worthwhile for the firm to reduce emissions to the point, where its marginal abatement cost are equal to the tax rate. Thus firms control pollution to different degrees *i.e.*, High cost controllers – less; low-cost controllers – more. The charge system encourages the industries to reduce the pollutants further. The collected charges can form a fund for restoration of the environment. Another form of pollution charge is a deposit refund system, where consumers pay a surcharge when purchasing a potentially polluting product, and receive a refund on return of the product after useful life span at appropriate centers. The concept of extended producers' responsibility is brought in to avoid accumulation of dangerous products in the environment.

- **Tradable permits:** Under this system, firms that achieve the emission levels below their allotted level may sell the surplus permits. Similarly the firms, which are required to spend more to attain the required degree of treatment/allotted levels, can purchase permits from others at lower costs and may be benefited.
- **Market barrier reductions:** Three known market barrier reduction types are as follows:
  - Market Creation: Measures that facilitate the voluntary exchange of water rights and thus promote more efficient allocation of scarce water supplies
  - Liability Concerns: Encourage firms to consider potential environmental damages of their decisions
  - Information Programmes: Ecolabeling and energy- efficiency product labeling requirements
- **Government subsidy reduction:** Subsidies are the mirror images of taxes and, in theory, can provide incentive to address environmental problems. However, it has been reported that the subsidies encourage economically inefficient and environmentally unsound practices, and often lead to market distortions due to differences in area. However, in the national interest, subsidies are important to sustain the expansion of production. In such cases, the subsidy may be comparable to the net social benefit.

### 2.3.2.3 Innovative funding mechanism

There are many forums under which the fund is made available for the issues which are of global/regional concern (GEF, OECD, Deutch green fund *etc.*) *i.e.* climate change, Basal Convention and further fund sources are being explored for the Persistent Organic Pollutants Convention. Besides the global funding mechanism, there needs to be localized alternative mechanisms for boosting the investment in environmental pollution control. For example, in India the Government has established mechanism to fund the common effluent treatment plants, which are specifically serving the small and medium scale enterprises *i.e.* 25% share by the state Government, matching grants from the Central Government and surety for 25% soft loan. It means that the industries need to invest only 25% initially, thus encouraging for voluntary compliance.

There are some more options *i.e.* if the pollution tax/charge is imposed on the residual pollution being caused by the industries, municipalities *etc.*, fund will automatically be generated, which in turn, can be utilized for funding the environmental improvement programmes. The emerging concept of build-operate-transfer (BOT) is an encouraging development, where there is a possibility to generate revenue by application of advanced technologies. There are many opportunities, which can be explored. However, what is required is the paradigm shift and focused efforts.

### 2.3.2.4 EMS and ISO certification

EMS is that part of the overall management system, which includes the organizational structure, responsibilities, practices, procedures, process and resources for determining and implementing the forms of overall aims, principles of action w.r.t the environment. It encompasses the totality of organizational, administrative and policy provisions to be taken by a firm to control its environmental influences. Common elements of an EMS are the identification of the environmental impacts and legal obligations, the development of



a plan for management & improvement, the assignment of the responsibilities and monitoring of the performance.

### 2.3.2.5 Total environment quality movement

Quality is regarded as

- A product attribute that had to be set at an acceptable level and balanced against the cost
- Something delivered by technical systems engineered by experts rather than the organization as a whole
- Assured primarily through the findings and correction of mistakes at the end of the production process

One expression of the total environment quality movement (TEQM) is a system of control called Kaizen. The principles of Kaizen are

- Goal must be continuous improvement of quality instead of acceptable quality
- Responsibility of quality shall be shared by all members of an organization
- Efforts should be focused on improving the whole process and design of products

With some modifications, TQM approach can be applied in improvement of corporate environmental performance in both process and product areas.

### 2.3.2.6 Eco-Labeling

Eco-labelling is the practice of supplying information on the environmental characteristics of a product or service to the general public. These labeling schemes can be grouped into three types:

- Type I: Multiple criteria base; third party (Govt. or non-commercial private organizations) programme claims overall environmental preferability
- Type II: Specific attribute of a product; often issued by a company/industrial association
- Type III: Agreed set of indices; provide quantified information; self declaration

Among the above, Type I are more reliable because they are established by a third party and considers the environmental impacts of a product from cradle to grave. However, the labeling program will only be effective if linked with complementary program of consumer education and up on restriction of umbrella claims by the producers.

### 2.3.2.7 Cleaner production

Cleaner production is one of the tools, which has lot of bearing on environmental pollution control. It is also seen that the approach is changing with time *i.e.*, dumping-to-control-to-recycle-to-prevention. Promotion of cleaner production principles involves an insight into the production processes not only to get desired yield, but also to optimize on raw material consumption *i.e.* resource conservation and implications of the waste treatment and disposal.

### 2.3.2.8 4-R concept

The concept endorses utilization of wastes as by-product to the extent possible *i.e.*, Recycle, Recover, Reuse, Recharge. Recycling refers to using wastes/by-products in the process again as a raw material to maximize production. Recovery refers to engineering means such as solvent extraction, distillation, precipitation, *etc.*, to separate useful constituents of wastes, so that these recovered materials can be used. Re-use refers to the utilization of waste from one process as a raw material to other. Recharging is an option in which the natural systems are used for renovation of waste for further use.

### 2.3.2.9 Eco-efficiency

The World Business Council on Sustainable Development (WBCSD) defines eco-efficiency as “the delivery of competitively priced goods and services that satisfy human needs and bring quality of life, while progressively reducing ecological impacts and resource intensity throughout the life cycle, to a level at least in line with earth’s carrying capacity”. The business implements the eco-efficiency on four levels *i.e.* optimized processes, recycling of wastes, eco-innovation and new services. Fussler (1995) defined six dimensions of eco efficiency, which are given below to understand/examine the system:

- **Mass:** There is an opportunity to significantly reduce mass burdens (raw materials, fuels, utilities consumed during the life cycle)
- **Reduce Energy Use:** The opportunity is to redesign the product or its use to provide significant energy savings
- **Reduce Environmental Toxins:** This is a concern to the environmental quality and human health. The opportunity here is to significantly control the dispersion of toxic elements
- **Recycle when Practical:** Designing for recyclability is important
- **Working with Mother Nature:** Materials are borrowed and returned to the nature without negatively affecting the balance of the ecosystem
- **Make it Last Longer:** It relates to useful life and functions of products. Increasing the functionality of products also increases their eco efficiency

The competitiveness among the companies and long-term survival will continue and the successful implementation of eco efficiency will contribute to their success. There is a need to shift towards responsible consumerism equal to the efficiency gains made by corporations – doing more with less.

### 2.3.2.10 Industrial ecosystem or metabolism

Eco-industrial development is a new paradigm for achieving excellence in business and environmental performance. It opens up innovative new avenues for managing business and conducting economic development by creating linkages among local ‘resources’, including businesses, non-profit groups, governments, unions, educational institutions, and communities. They can creatively foster dynamic and responsible growth. Antiquated business strategies based on isolated enterprises are no longer responsive enough to market, environmental and community requirements.

Sustainable eco-industrial development looks systematically at development, business and environment, attempting to stretch the boundaries of current practice - on one level. It is as directly practical as making the right connections between the wastes and resources needed for production and at the other level, it is a whole new way of thinking about doing business and interacting with communities. At a most basic level, it is each organization seeking higher performance within it self. However, most eco-industrial activity is moving to a new level by increasing the inter connections between the companies.

Strategic partnership, networked manufacturing and performed supplier arrangements are all the examples of ways used by the businesses to ensure growth, contain costs and to reach out for new opportunities.

For most businesses, the two essentials for success are the responsive markets and access to cost-effective, quality resources for production or delivering services. In absence of these two factors, virtually every other incentive becomes a minor consideration.

Transportation issues are important at two levels, the ability to get goods to market in an expeditious way is essential to success in this day of just in time inventories. The use of least impact transportation with due consideration of speed and cost supports business success and addresses the concerned in community.

Eco-industrial development works because it consciously mixes a range of targeted strategies shaped to the contours of the local community. Most importantly, it works because the community wants nothing less than the best possible in or near their neighborhood. For companies, it provides a path towards significantly higher operating results and positive market presence. For our environment, it provides great hope that the waste will be transformed into valued product and that the stewardship will be a joint pledge of both businesses and communities.

### 2.3.2.11 Voluntary agreements

Voluntary environmental agreements among the industries, government, public representatives, NGOs and other concerned towards attaining certain future demands of the environment are reported to be successful. Such agreements may be used as a tool where Government would like to make the standards stringent in future (phase-wise-stringent). These may be used when conditions are temporary and require timely replacements. Also these may be used as supplementary/ complimentary in implementation of the regulation. The agreements may include:

- Target objectives (emission limit values/standards)
- Performance objectives (operating procedures)
- R&D activities – Government and industry may have agreement to establish better control technologies.
- Monitoring & reporting of the agreement conditions by other agents (NGOs, public participants, civil authority *etc.*)

In India, the MoEF has organized such programme, popularly known as the corporate responsibility for environment protection (CREP) considering identified 17 categories of high pollution potential industrial sectors. Publication in this regard, is available with Central Pollution Control Board (CPCB).

### 2.3.3 Tools for communication

#### 2.3.3.1 State of environment

The Government of India has brought out the state of environment report for entire country and similar reports are available for many of the states. These reports are published at regular intervals to record trends and to identify the required interventions at various levels. These reports consider the internationally accepted DPSIR framework for the presentation of the information. DPSIR refers to

- D – Driving forces – causes of concern *i.e.* industries, transportation *etc.*
- P – Pressure – pollutants emanating from driving forces *i.e.* emission
- S – State – quality of environment *i.e.* air, water & soil quality
- I – Impact – Impact on health, ecosystem, materials, biodiversity, economic damage *etc.*
- R – Responses – action for cleaner production, policies (including standards/guidelines), targets *etc.*

Environment reports including the above elements give a comprehensive picture of specific target area in order to take appropriate measures for improvement. Such reports capture the concerns which could be considered in EIAs.

#### 2.3.3.2 Corporate environmental reporting

Corporate environmental reports (CERs) are only one form of environmental reporting defined as publicly available, stand alone reports, issued voluntarily by the industries on their environmental activities. CER is just a means of environmental improvement and greater accountability, not an end in itself.

Three categories of environmental disclosure are:

- Involuntary Disclosure: Without its permission and against its will (env. Campaign, press *etc.*)
- Mandatory Disclosure: As required by law
- Voluntary Disclosure: The disclosure of information on a voluntary basis

## 2.4 Objectives of EIA

Objectives of EIA include the following:

- To ensure environmental considerations are explicitly addressed and incorporated into the development decision-making process;
- To anticipate and avoid, minimize or offset the adverse significant biophysical, social and other relevant effects of development proposals;
- To protect the productivity and capacity of natural systems and the ecological processes which maintain their functions; and
- To promote development that is sustainable and optimizes resource use as well as management opportunities

## 2.5 Types of EIA

Environmental assessments could be classified into four types *i.e.* strategic environmental assessment, regional EIA, sectoral EIA and project level EIA. These are precisely discussed below:

### Strategic environmental assessment

Strategic Environmental Assessment (SEA) refers to systematic analysis of the environmental effects of development policies, plans, programmes and other proposed strategic actions. SEA represents a proactive approach to integrating environmental considerations into the higher levels of decision-making – beyond the project level, when major alternatives are still open.

### Regional EIA

EIA in the context of regional planning integrates environmental concerns into development planning for a geographic region, normally at the sub-country level. Such an approach is referred to as the economic-cum-environmental (EcE) development planning). This approach facilitates adequate integration of economic development with management of renewable natural resources within the carrying capacity limitation to achieve sustainable development. It fulfils the need for macro-level environmental integration, which the project-oriented EIA is unable to address effectively. Regional EIA addresses the environmental impacts of regional development plans and thus, the context for project-level EIA of the subsequent projects, within the region. In addition, if environmental effects are considered at regional level, then cumulative environmental effects of all the projects within the region can be accounted.

### Sectoral EIA

Instead of project-level-EIA, an EIA should take place in the context of regional and sectoral level planning. Once sectoral level development plans have the integrated sectoral environmental concerns addressed, the scope of project-level EIA will be quite narrow. Sectoral EIA will help in addressing specific environmental problems that may be encountered in planning and implementing sectoral development projects.

### Project level EIA

Project level EIA refers to the developmental activity in isolation and the impacts that it exerts on the receiving environment. Thus, it may not effectively integrate the cumulative effects of the development in a region.

From the above discussion, it is clear that EIA shall be integrated at all the levels *i.e.* strategic, regional, sectoral and the project level. Whereas, the strategic EIA is a structural change in the way the things are evaluated for decision-making, the regional EIA refers to substantial information processing and drawing complex inferences. The project-level EIA is relatively simple and reaches to meaningful conclusions. Therefore in India, project-level EIA studies take place on a large-scale and are being considered. However, in the re-engineered Notification, provisions have been incorporated for giving a single clearance for the entire industrial estate for *e.g.*, Leather parks, pharma cities *etc.*, which is a step towards the regional approach.

As we progress and the resource planning concepts emerge in our decision-making process, the integration of overall regional issues will become part of the impact assessment studies.

## 2.6 Basic EIA Principles

By integrating the environmental impacts of the development activities and their mitigation early in the project planning cycle, the benefits of EIA could be realized in all stages of a project, from exploration and planning, through construction, operations, decommissioning, and beyond site closure.

A properly-conducted-EIA also lessens conflicts by promoting community participation, informing decision makers, and also helps in laying the base for environmentally sound projects. An EIA should meet at least three core values (EIA Training Resource Manual, UNEP 2002,):

- Integrity: The EIA process should be fair, objective, unbiased and balanced
- Utility: The EIA process should provide balanced, credible information for decision-making
- Sustainability: The EIA process should result in environmental safeguards

Ideally an EIA process should be:

- Purposive- should inform decision makers and result in appropriate levels of environmental protection and community well-being.
- Rigorous- should apply “best practicable” science, employing methodologies and techniques appropriate to address the problems being investigated.
- Practical- should result in providing information and acceptable and implementable solutions for problems faced by proponents.
- Relevant- should provide sufficient, reliable and usable information for development planning and decision making.
- Cost-effective-. should impose minimum cost burdens in terms of time and finance on proponents and participants consistent with meeting accepted requirements and objectives of EIA
- Efficient- should achieve the objectives of EIA within the limits of available information, time, resources and methodology.
- Focused- should concentrate on significant environmental effects and key issues; *i.e.*, the matters that need to be taken into account in making decisions.
- Adaptive- should be adjusted to the realities, issues and circumstances of the proposals under review without compromising the integrity of the process, and be iterative, incorporating lessons learned throughout the project life cycle.
- Participative- should provide appropriate opportunities to inform and involve the interested and affected publics, and their inputs and concerns should be addressed explicitly in the documentation and decision making.
- Inter-disciplinary- should ensure that appropriate techniques and experts in relevant bio-physical and socio-economic disciplines are employed, including use of traditional knowledge as relevant.

- Credible- should be carried out with professionalism, rigor, fairness, objectivity, impartiality and balance, and be subject to independent checks and verification.
- Integrated- should address the interrelationships of social, economic and biophysical aspects.
- Transparent- should have clear, easily understood requirements for EIA content; ensure public access to information; identify the factors that are to be taken into account in decision making; and acknowledge limitations and difficulties.
- Systematic- should result in full consideration of all relevant information on the affected environment, of proposed alternatives and their impacts, and of the measures necessary to monitor and investigate residual effects.

## 2.7 Project Cycle

The generic project cycle including that of Distilleries has six main stages:

1. Project concept
2. Pre-feasibility
3. Feasibility
4. Design and engineering
5. Implementation
6. Monitoring and evaluation

It is important to consider the environmental factors on an equal basis with technical and economic factors throughout the project planning, assessment and implementation phases. Environmental consideration should be introduced at the earliest in the project cycle and must be an integral part of the project pre-feasibility and feasibility stage. If the Environmental considerations are given due respect in the site selection process by the project proponent, the subsequent stages of the environmental clearance process would get simplified and would also facilitate easy compliance to the mitigation measures throughout the project life cycle.

A project's feasibility study should include a detailed assessment of significant impacts and the EIA include a detailed prediction and quantification of impacts and delineation of Environmental Management Plans (EMP). Findings of the EIA study should preferably be incorporated in the project design stage so that the project is studied, site alternatives are required and necessary changes, if required, are incorporated in the project sight at the design stage. This practice will also help the management in assessing the negative impacts and in designing cost-effective remedial measures. In general, EIA enhances the project quality and improves the project planning process.

## 2.8 Environmental Impacts

Environmental impacts resulting from proposed actions can be grouped into following categories:

- Beneficial or detrimental
- Naturally reversible or irreversible
- Repairable via management practices or irreparable
- Short term or long term

- Temporary or continuous
- Occurring during construction phase or operational phase
- Local, regional, national or global
- Accidental or planned (recognized before hand)
- Direct (primary) or Indirect (secondary)
- Cumulative or single

The category of impacts as stated above, and its significance will facilitate the expert appraisal committee (EAC)/State Level EAC (SEAC) to take a look at the ToR for EIA studies, as well as, in decision making process about the developmental activity.

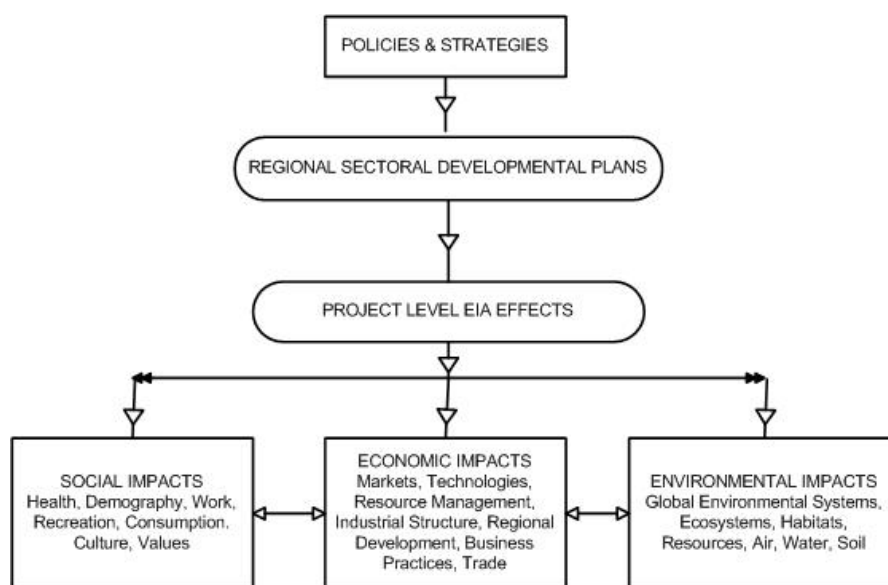

**Figure 2-2: Types of Impacts**

The nature of impacts could fall within three broad classifications *i.e.*, direct, indirect and cumulative, based on the characteristics of impacts. The assessment of direct, indirect and cumulative impacts should not be considered in isolation or considered as separate stages in the EIA. Ideally, the assessment of such impacts should form an integral part of all stages of the EIA. The TGM does not recommend a single method to assess the types of impacts, but suggests a practical framework/approach that can be adapted and combined to suit a particular project and the nature of impacts.

### 2.8.1 Direct impacts

Direct impacts occur through direct interaction of an activity with an environmental, social, or economic component. For example, a discharge of distilleries or an effluent from the Effluent Treatment Plant (ETP) from the Distillery units into a river may lead to a decline in water quality in terms of high biochemical oxygen demand (BOD) or dissolved oxygen (DO).

### 2.8.2 Indirect impacts

Indirect impacts on the environment are those which are not a direct result of the project, often produced away from or as a result of a complex impact pathway. The indirect impacts are also known as secondary or even tertiary level impacts. For example, ambient air SO<sub>2</sub> rise due to stack emissions may deposit on land as SO<sub>4</sub> and cause acidic



soils. Another example of indirect impact, is the decline in water quality due to rise in temperature of water bodies receiving cooling water discharge from the nearby industry. This, in turn, may lead to a secondary indirect impact on aquatic flora in that water body and may further cause reduction in fish population. Reduction in fishing harvests, affecting the incomes of fishermen is a third level impact. Such impacts are characterized as socio-economic (third level) impacts. The indirect impacts may also include growth-inducing impacts and other effects related to induced changes to the pattern of land use or additional road network, population density or growth rate. In the process, air, water and other natural systems including the ecosystem may also be affected.

### 2.8.3 Cumulative impacts

Cumulative impact consists of an impact that is created as a result of the combination of the project evaluated in the EIA together with other projects in the same vicinity causing related impacts. These impacts occur when the incremental impact of the project is combined with the cumulative effects of other past, present and reasonably foreseeable future projects. Figure 2-3 depicts the same. Respective EAC may exercise their discretion on a case-by-case basis for considering the cumulative impacts.

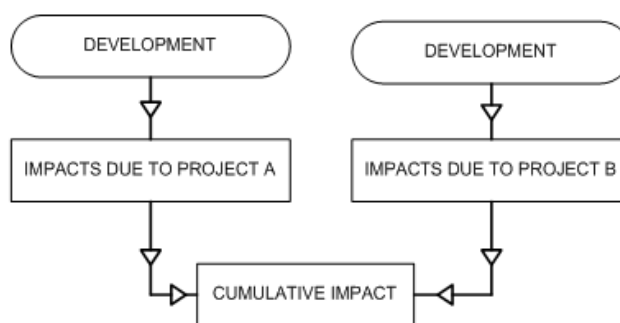

Figure 2-3: Cumulative Impact

### 2.8.4 Induced impacts

The cumulative impacts can be due to induced actions of projects and activities that may occur if the action under assessment is implemented such as growth-inducing impacts and other effects related to induced changes to the pattern of future land use or additional road network, population density or growth rate (e.g. excess growth may be induced in the zone of influence around a distillery project, and in the process causing additional effects on air, water and other natural ecosystems). Induced actions may not be officially announced or be a part of any official plan. Increase in workforce and nearby communities contributes to this effect.

They usually have no direct relationship with the action under assessment, and represent the growth-inducing potential of an action. New roads leading from those constructed for a project, increased recreational activities (e.g., hunting, fishing), and construction of new service facilities are examples of induced actions.

However, the cumulative impacts due to induced development or third level or even secondary indirect impacts are difficult to be quantified. Because of higher levels of uncertainties, these impacts cannot normally be assessed over a long time horizon. An EIA practitioner usually can only guess as to what such induced impacts may be and the

possible extent of their implications on the environmental factors. Respective EAC may exercise their discretion on a case-by-case basis for considering the induced impacts.

## 2.9 Significance of Impacts

This TGM establishes the significance of impacts first and proceeds to delineate the associated mitigation measures. So the significance here reflects the “worst-case scenario” before mitigation is applied, and therefore provides an understanding of what may happen if mitigation fails or is not as effective as predicted. For establishing significance of different impacts, understanding the responses and interaction of the environmental system is essential. Hence, the impact interactions and pathways are to be understood and established first. Such an understanding will help in the assessment process to quantify the impact as accurately as possible. Complex interactions, particularly in the case of certain indirect or cumulative impacts, may give rise to non-linear responses which are often difficult to understand and therefore their significance is difficult to assess. It is hence understood that indirect or cumulative impacts are more complex than the direct impacts. Currently the impact assessments are limited to direct impacts. In case mitigation measures are delineated before determining significance of the effect, the significance represents the residual effects.

However, the ultimate objective of an EIA is to achieve sustainable development. The development process shall invariably cause some residual impacts even after implementing an EMP effectively. Environmentalists today are faced with a vital, not-easy-to-answer question—“What is the tolerable level of environmental impact within the sustainable development framework?” As such, it has been recognized that every ecosystem has a threshold for absorbing deterioration and a certain capacity for self-regeneration. These thresholds based on concept of carrying capacity are as follows:

- Waste emissions from a project should be within the assimilative capacity of the local environment to absorb without unacceptable degradation of its future waste absorptive capacity or other important services.
- Harvest rates of renewable resource inputs should be within the regenerative capacity of the natural system that generates them; depletion rates of non-renewable inputs should be equal to the rate at which renewable substitutes are developed by human invention and investment.

The aim of this model is to curb over-consumption and unacceptable environmental degradation. But because of limitation in available scientific basis, this definition provides only general guidelines for determining the sustainable use of inputs and outputs. To establish the level of significance for each identified impact, a three-stage analysis may be referred:

- First, an impact is qualified as being either negative or positive.
- Second, the nature of impacts such as direct, indirect, or cumulative is determined using the impact network
- Third, a scale is used to determine the severity of the effect; for example, an impact is of low, medium, or high significance.

It is not sufficient to simply state the significance of the effect. This determination must be justified, coherent and documented, notably by a determination methodology, which must be described in the methodology section of the report. There are many recognized methodologies to determine the significance of effects.

### 2.9.1 Criteria/methodology to determine the significance of the identified impacts

The criteria can be determined by answering some questions regarding the factors affecting the significance. This will help the EIA stake-holders, the practitioner in particular, to determine the significance of the identified impacts eventually. Typical examples of such factors (one approach reported by Duval and Vonk 1994) include the following:

- Exceedance of a threshold: Significance may increase if a threshold is exceeded. *e.g.* Emissions of SO<sub>2</sub> and/or PM10 exceed the permissible threshold.
- Effectiveness of mitigation: Significance may increase as the effectiveness of mitigation measures decreases. *e.g.*, control technologies, which may not assure consistent compliance to the requirements.
- Size of study area: Significance may increase as the zone of effects increases *e.g.* High temperature discharge from a cooling tower in sea may impact the mangrove ecology at a distant location.
- Incremental contribution of effects from action under review: Significance may increase as the relative contribution of an action increases.
- Relative contribution of effects of other actions: Significance may decrease as the significance of nearby larger actions increase.
- Relative rarity of species: Significance may increase as species becomes increasingly rare or threatened.
- Significance of local effects: Significance may increase as the significance of local effects is high.
- Magnitude of change relative to natural background variability: Significance may decrease if effects are within natural assimilative capacity or variability.
- Creation of induced actions: Significance may increase as induced activities also highly significant.
- Degree of existing disturbance: Significance may increase if the surrounding environment is pristine:

For determining significance of impacts, it is important to remember that secondary and higher order effects can also occur as a result of a primary interaction between a project activity and the local environment. Wherever a primary effect is identified, the practitioner should always think if secondary or tertiary effects on other aspects of the environment could also arise.

The EIA should also consider the effects that could arise from the project due to induced developments, which take place as a consequence of the project. Ex Population density and associated infrastructure and jobs for people attracted to the area by the project. It also requires consideration of cumulative effects that could arise from a combination of the effects due to other projects with those of other existing or planned developments in the surrounding area. So the necessity to formulate a qualitative checklist is suggested to test significance, in general.

# 3. ABOUT DISTILLERIES INCLUDING PROCESS AND POLLUTION CONTROL TECHNOLOGIES

## 3.1 Introduction

A distilled beverage, liquor, or spirit is a potable liquid containing ethanol produced by distillation of fermented grain, fruit, or vegetables. There are about 295 distilleries in India, mostly concentrated in Maharashtra, Uttar Pradesh, Andhra Pradesh, Karnataka, Tamil Nadu, Gujarat and Madhya Pradesh. The process of distillation results in release of large amounts of waste and wastewater, which have a considerable environmental impact by polluting both water bodies and soil, by causing an adverse climatic effect as well as odour nuisance. The effluent generated from the distillery is highly colored and contains high organic as well as inorganic substances. The effluents of distillery require comprehensive treatment to meet the prescribed standard for disposal into inland water. Distillery is, therefore, one of the highly water polluting industry and is also listed as one among the 17 categories of highly polluting industries.

### Etymology of liquor

The source for 'liquor' and its close relative, liquid, come from the Latin verb *liquere*, meaning 'to be fluid.' According to the Oxford English Dictionary (OED), an early use of the word in English, meaning simply 'a liquid', can be dated back to 1225. From early use to the mid 1300s 'liquor' according to OED was the 'liquid for drinking', while it was referred as an 'intoxicating alcoholic drink' by the 16<sup>th</sup> Century.

### Chemistry of alcohol

In chemistry, alcohol is a general term for any organic compound in which a hydroxyl group (-OH) is bound to a carbon atom, which in turn may be bound to other carbon atoms and further hydrogens. Ethanol is classified as a primary alcohol, meaning that the carbon to which its hydroxyl group is attached has at least two hydrogen atoms attached to it as well.

The chemistry of ethanol is largely that of its hydroxyl group. (CH<sub>3</sub>CH<sub>2</sub>OH), the active ingredient in alcoholic drinks, for consumption purposes is always produced by fermentation – the metabolism of carbohydrates – by certain species of yeast in the absence of oxygen. The process of culturing yeast under alcohol-producing conditions is referred to as brewing. The same process produces CO<sub>2</sub> in situ, and may be used to carbonate the drink. However, this method leaves yeast residues and on the industrial scale, carbonation is usually done separately.

Drinks with a concentration of more than 50% ethanol by volume (100 US proof) are flammable liquids and easily ignited. Some exotic drinks gain their distinctive flavours through intentional ignition, such as the Flaming Dr. Pepper. Spirits with higher ethanol content can be ignited with ease by heating slightly, e.g., adding the spirit to a warmed shot glass.

Other alcohols such as propylene glycol and the sugar alcohols may appear in food or beverages regularly, but these alcohols do not make them alcoholic. Methanol (one carbon), the propanols (three carbons giving two isomers), and the butanols (four carbons, four isomers) are all commonly found alcohols, and none of these three should ever be consumed in any form. Alcohols are toxicated into the corresponding aldehydes and then into the corresponding carboxylic acids. These metabolic products cause a poisoning and acidosis. In the case of other alcohols than ethanol, the aldehydes and carboxylic acids are poisonous and the acidosis can be lethal. In contrast, fatalities from ethanol are mainly found in extreme doses and related to induction of unconsciousness or chronic addiction (alcoholism).

### 3.1.1 Industrial distillation process – history

The first evidence of distillation comes from Babylonia and dates from the 2<sup>nd</sup> millennium BC. Specially-shaped clay pots were used to extract small amounts of distilled alcohol through natural cooling for use in perfumes. By the 3<sup>rd</sup> century A.D. alchemists in Alexandria, Egypt, may have used an early form of distillation to produce alcohol for sublimation or for colouring metal.

In 1437 burned water (brandy) was mentioned in the records of the county of Katzenelnbogen in Germany. It was served in a tall, narrow glass called a ‘*goderulffe*’

Claims upon the origin of specific beverages are controversial, often invoking national pride, but they are plausible after the 12<sup>th</sup> century A.D., when Irish whisky and German brandy became available. These spirits would have had a much lower alcohol content (about 40% ABV) than the alchemists’ pure distillations, and they were likely first thought of as medicinal Elixirs. Consumption of distilled beverages rose dramatically in Europe in and after the mid 14<sup>th</sup> Century, when distilled liquors were commonly used as remedies for the Black Death. Around 1400 it was discovered how to distill spirits from wheat, barley, and rye beers; even sawdust was used to make alcohol, a much cheaper option than grapes. Thus began the ‘national’ drinks of Europe: *jenever* (Belgium and the Netherlands), gin (England), *schnapps* (Germany), *grappa* (Italy), *akvavit* (Scandinavia), vodka (Russia and Poland), *rakia* (the Balkans), *poitín* (Ireland). The actual names only emerged in the 16<sup>th</sup> Century but the drinks were well-known prior to that date.

### 3.1.2 Ethanol production– world scenario

World production of ethanol in 2006 was 51 giga litres (1.3×10<sup>10</sup> US gal), with 69% of the world supply coming from Brazil and the United States. More than 20% of the Brazilian fleet of cars on the streets is able to use 100% ethanol as fuel, which includes ethanol-only engines and flex-fuel engines. Flex-fuel engines in Brazil are able to work with all ethanol, all gasoline or any mixture of both. In the US flex-fuel vehicles can run on 0% to 85% ethanol (15% gasoline) since higher ethanol blends are not yet allowed. Brazil supports the population of ethanol-burning automobiles with large national infrastructure that produces ethanol from domestically grown sugarcane. Sugarcane not only has a greater concentration of sucrose than corn (by about 30%), but also is much easier to extract. The bagasse generated by the process is not wasted, but is utilized in power plants as a surprisingly efficient fuel to produce electricity.

Figure 3-1 shows the unweighed means of adult per capita consumption across all countries for total consumption, and beer, wine and spirits separately. Unweighed here means that the corresponding population size of countries was not used, and hence each

country received the same weight. From the total alcohol consumption, close to equal parts are made up of beer, wine and spirits respectively. For all years, the mean adult per capita is 5.1 litres of pure alcohol, of which beer accounts for 1.9 litres, wine 1.3 litres and spirits 1.7 litres.

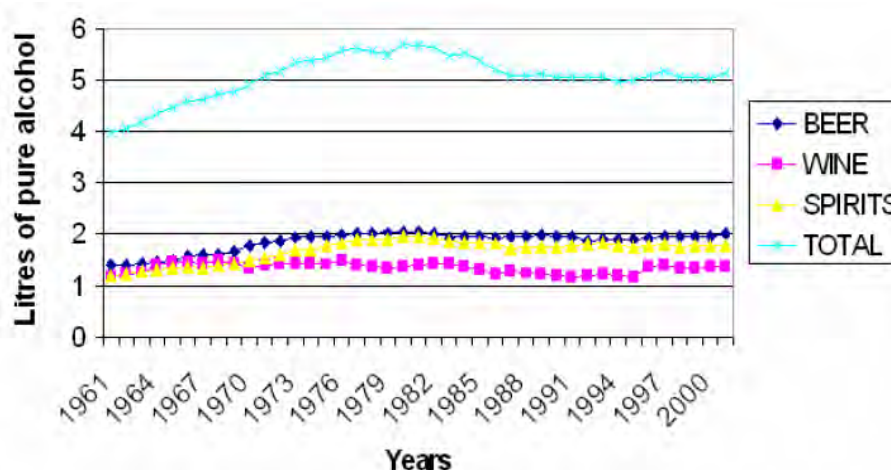

Figure 3-1: Global Per capita Consumption (Unweighed) till 2001

### 3.2 Indian context

There are basically five categories of alcoholic beverages – beer; wine, and Indian Made Foreign Liquor (IMFL), country liquor and toddy. IMFL includes whisky, rum, vodka and other similar spirits. Country liquor is the indigenous equivalent of IMFL – essentially, flavoured alcohol, with alcohol content somewhat less than the standard for IMFL. Toddy is a mildly fermented juice extracted from palm and may be considered the indigenous equivalent of beer, in terms of alcohol content.

An estimated current production of alcoholic beverage industry’s 480 million cases – consisting of country liquor (local spirits such as feni, toddy, and arrack are collectively called country liquor), whisky, brandy, rum, vodka, beer and wine.

Wine production is a little above 785,000 cases (twelve 0.75 litre bottles), which is relatively negligible when compared with the other alcoholic beverages. Though dwarfed in market size and volume by other categories in the alcoholic beverage industry, wine has attracted a great deal of the country’s attention in recent years. The Indian wine industry, although miniscule in size when compared to other countries worldwide, is in its infancy and holds promise buoyed by impressive economic growth and growth of the consuming class. A compound average growth rate (CAGR) of over 25% over the last six years, although from a lower base, has attracted high participation from local entrepreneurs, foreign liquor companies and private equity firms, which has caused increased local interest in understanding the various growth drivers, industry structure and strategic decisions shaping the Indian wine industry.

The term ‘fermentation industry’ in India, covers a very large number of industries in which the reactions with the help of micro organisms is the major feature. Many of these industries do not exist in India while only a few fermentation industries are in function that too at the rate of only one or two plants in the country. So the Indian fermentation industry categorized as Maltry, Brewery and Distillery based on either molasses or grain.

### a) Maltry

Malt is produced from grains, usually barley and less commonly wheat or other cereals. The major process steps are steeping, germination and kilning. Steeping is done to clean the grain and initiate germination. The operation comprises adding water in adequate quantity, along with certain additives if required. The water is changed two-to-four times and a total steep cycle of 24-60 hours is employed, as determined by the subjective judgement of the maltry depending on a variety of factors, from dormancy of the grain to climatic conditions. The germination or malting may be done in a variety of ways. In India, the common practice is floor malting. In this the steeped grain is put in a couch, and when germination begins, it is spread on the floor for 7-10 days, depending on the nature of the grain and germination conditions. When it is judged that an optimum amount of enzymatic breakdown of the original high molecular weight compounds has taken place, the green malt is kilned to arrest germination and fix the desirable properties like flavour, aroma and viability. The kilning process comprises of initial drying at 30-40°C followed by curing at 70-105 °C.

The plant practices that lead to pollution are:

- Throwing the skimmings from steep vessels on the floor, which are eventually drained during floor washing.
- Spillage of grains during manual transfer from one germination box to another;
- Spillage of rootlets

In general, the wastewater in open drains of maltries is rich in suspended solids and creates a characteristic foul odour due to deterioration.

### b) Brewery

In the breweries, the malt is milled to very coarse flour called 'grist', which is then extracted in water in a process called 'mashing'. There are three chief methods of mashing, viz. infusion mashing, decoction mashing and double mashing. In India, the common practice is decoction mashing in which, unlike in the other systems, cooking of the malted cereal is not involved. The extract from the mashing step, called 'sweet wort' is fed into 'lauter tun' where about 25-30% of the grain fed for mashing is removed. The sweet wort is then boiled in the 'brew kettle' to arrest the enzymatic action, sterilize it and precipitate some protein matters. Hops, which impart the characteristics flavour and bitterness to the beer, and sugar are also added in the brew kettle. The spent hops are separated in a 'hop jack' or on a strainer, and the 'bitter wort' is passed through whirlpools, where it entraps some air and some of the resins are precipitated. The bitter wort is cooled to 10-15°C and fermented by yeast over a period of 6-14 days, the usual cycle in India being 10 days. The 'green beer' so obtained is lagered for 1-2 months, during which much of the suspended matter settles down. It is then filtered, bottled and pasteurised.

The brewery in general is a clean industry. Most plants are imported and foreign plant practices are generally followed, as the brew masters are usually trained abroad. In some plants hop extract is used instead of hops, when there are no spent hops to be disposed off.

### c) Distillery

In India, the potable alcohols of different varieties are not made from different feedstock. Practically, all are made by blending suitable colours, flavours, additives, *etc.*, to rectified spirit made from the fermentation of molasses. Only a small amount of alcohol is made from malt for preparation of whisky. The major quantity of rectified spirit is used for industrial purposes.

#### i) Distilleries based on cereals

In the distilleries based on cereals, malt is the starting material and the initial processing steps are very similar to those in a brewery, except that the mash is not brewed and hops is not added. Yeast is propagated separately in the medium of malt mash of about 15% solids content and, added to the prepared wort in fermenters, where the alcohol concentration rises to 6.5 - 8.5% by volume. This beer is distilled in a beer still and the hops, after steam stripping in an aldehyde column, are further fractionated in a rectifying column to obtain 190° proof alcohol. The bottom discharge from the beer still is practically free from alcohol but contains other organic and inorganic solids in solution of about 6-8% concentration, is called 'stillage' and is the major wastewater stream, corresponding to the spent wash from molasses-based distilleries.

The plant practices are closely guarded and not much is known about the variations.

#### ii) Distilleries based on molasses

Molasses, a by-product of sugar industry is used as raw material by most of the distilleries for production of alcohol by fermentation and distillation processes. The molasses contains about 40-50% sugar, which is diluted to bring sugar contents to 10-15% or 20-25° Brix for further fermentation process. The pH is adjusted by addition of sulphuric acid, if necessary.

Yeast culture is done in the laboratory and propagated in a series of fermenters, each about 10 times larger than the previous one. The diluted molasses is inoculated with about 10% by volume of yeast inoculum. In the fermenters the reducible sugars are broken down to ethyl alcohol and carbon dioxide (CO<sub>2</sub>). The reaction is exothermic and cooling water is sprayed on the fermenter walls to maintain the temperature at 29 - 32°C. Sludge is produced and discharged from the bottom, while the clear fermented beer from the top is sent to the degasifying section of the analyser column after the heat exchange with the spent wash to preheat it to about 90°C. In the analyser which is a bubble-Cap-fractionating column, the beer is heated by live steam and fractionated to give a 40% alcohol stream from the top. This stream is further fractionated in the rectifier column to obtain rectified spirit. Part of the rectified spirit is sent back to the column, and the condensed water from this stage, known as 'spent lees' is usually pumped back to the analyser column. The bottom discharge from the analyser column is known as the spent wash, which is drained off after heat exchange with the incoming beer from the fermenters.

The plant practices are practically uniform throughout the country. In the fermenter section there is no variation which has relevance to aspects of pollution. House keeping practices regarding wash water collection and sludge disposal vary somewhat. In the distillation section, a few plants have extra fractionating columns for removal of aldehydes and fusel oil (Fusel alcohols, also sometimes called fusel oils, or potato oil in Europe, are higher-order alcohols (that is, alcohols with more than two carbon atoms)



formed by fermentation and present in cider, mead, beer, wine, and spirits to varying degrees), or for production of so-called silent spirits. These, however, have no practical relevance to pollution.

### 3.3 Distilling Processes Based on Raw Materials

In terms of raw material and process differences, two types of distilleries are in existence in India. Process descriptions of each are discussed in subsequent sections.

#### 3.3.1 Distilled liquor based on cereals

Sequentially, cereal-based distilleries involve the following major process steps.

- Milling - Reduction of particle size prior to hydration
- Cooking - Hydration and gelatinization of starch
- Conversion - Enzymatic hydrolysis of starch
- Fermentation - Production of ethyl alcohol
- Distillation - Product recovery

The processes of milling, cooking, conversion and fermentation in cereal based distilleries are similar to those followed in breweries with the exception that the brewing step is not carried out. In these distilleries, mashing, which includes cooking and conversion as in the case of breweries, is carried out in different types of mash tuns which are large cookers. Conversion of grain and malt occurs at a temperature of 50-70°C. Requirement of water during cooking is 5-7 L/kg of grain and that during malt slurry preparation is 8-9 L/kg of malt.

Mashing normally takes between 2.5 and 3 hours, at the end of which, the mash is cooled to a temperature of 25-30°C and transferred to fermenters where it is inoculated with cultured yeast.

Preparation of yeast for inoculation of the fermenters is done initially in the laboratory and the yeast population is grown in successively increasing stages in the plant where malt mash of about 15% solid concentration is inoculated in each stage with 2 to 5% by volume of culture from the preceding stage. Each inoculation stage lasts for about 24 hours. The final composition in the main fermenters is generally maintained at 8-12 L of water for every kg of grain processed.

The fermented beer which contains 6.5 to 8.5% ABV is pumped into the upper section of the beer still (distillation column). Direct steam, entering the bottom of this column, strips the alcohol from the beer and passes into another distillation column known as the aldehyde column where it is again steam stripped and the main stream of alcohol at low proof is pumped from the base of the aldehyde column into the rectifying column for further purification. Alcohol of about 190° proof is drawn from the top of the rectifier column while water is discharged from its base.

Fusel oil is a by-product withdrawn three or four plates above the feed point in the aldehyde column and constitutes about 10% of the product stream. The lighter fractions, known as the heads and consisting mainly of aldehyde, esters, *etc.*, are withdrawn from the top of this column and constitute about 5% of the product stream.

The beer, free from alcohol but containing other inorganic and organic solids in solution, is discharged from the base of the beer still. This stream is commonly known as stillage and contains 6-8% solids. Stillage is the source of recovery for distillers' grain in most distilleries abroad.

### 3.3.2 Distilled liquor based on molasses

In general the layout of most distilleries is similar and can be divided into two broad sections. The first section houses laboratory; yeast propagation vessels, diluters, pre-fermenters and fermentation vessels. The second section houses all the distillation columns condensers and heat exchangers.

The first section generally has two floors with equipment like diluter, pre-fermenters, *etc.*, and laboratory placed on the first. Fermentation vessels are laid on the ground floor with their tops extending about 1.5 m into the first floor. The ground floor of the fermenter is usually wet because of the cooling water sprayed on the outer walls of the fermenters. This water splashes on the floor and flows out through open channels on the floor along with fermenter sludge and wash water.

The yeast propagation vessels are generally closed reactors where strict temperature control is maintained. The diluter in most of the distilleries is of continuous type where the molasses and water streams are pumped into two coaxial tubes in a closed vessel. The two streams get thoroughly mixed by the high turbulence before they flow into the fermenters. A single diluter with a diameter of about 300-400 m, an overall height of about 3,000-101 and a capacity of about 15,000 to 30,000 L of diluted molasses per hour is commonly used for continuous dilution. Generally, the continuous diluter is cleaned once in a day with water and steam. There is no process waste stream produced from yeast propagation vessels, diluter and pre-fermenters except the wash waters used for cleaning after processing cycles. Most of the distilleries have open top fermenters where CO<sub>2</sub> is generally not recovered. Table 3-1 presents information regarding the capacities of total number of vessels and vessels processed per day in some of the distilleries in the country.

**Table 3-1: Capacity of Fermentation Vessels in Distilleries**

S.No.	Installed Capacity of the Unit in kL	Type of Diluter in use	No. of Fermenters	Capacity of Fermenters in Cubic Metres	No. of Fermenter discharges per day
1	7,500	Continuous	5	5 x 90	3
2	8,864	Continuous	10	10 x 180	3
3	12,000	Continuous	10	10 x 140	6
4	5,345	Batch	16	900 (Total)	7
5	1,881	Batch	18	10 to 18 (each)	8
6	2,970	Batch	12	12 x 17	8
7	2,175	Batch	4	4 x 60	1-2
8	9,000	Continuous	12	12 x 105	6
9	9,228	Continuous	17	8 x 65 4 x 75 & 5 x 110	10-12

S.No.	Installed Capacity of the Unit in kL	Type of Diluter in use	No. of Fermenters	Capacity of Fermenters in Cubic Metres	No. of Fermenter discharges per day
10	5,700	Continuous	8	6 x 90 2 x 100	3
11	6,800	Continuous	9	5 x 50 4 x 15	3

### Water use

Water used in molasses-based distilleries are:

- Process Application
  - Yeast propagation
  - Preparation of molasses for fermentation
  - Water (as steam) required for distillation
- Non-process Applications
  - Cooling water
  - Treated water for making potable liquor (IMFL) and for boiler use
  - Water and steam required for washing

Table 3-2 gives the range and average water used in the various applications mentioned above. On an average, the total water requirement is 85 m<sup>3</sup>/k of RS plus about 50 m<sup>3</sup>/day of soft treated water. For a distillery of 5,000 kL per annum capacity this will work out to about 90 m<sup>3</sup> /kL of RS produced. The basis of the figures is also mentioned in the following table:

**Table 3-2: Process & Non-Process Application of Water for Molasses Based Distilleries**

Use	m <sup>3</sup> of rectified spirit produced (Range)	Average	Basis & Remarks
<b>A. PROCESS APPLICATIONS</b>			
Yeast propagation	1.0-1.4	1.3	Data collected from 10 distilleries
Preparation of Molasses for	5-6	5.5	Data collected from 12 Distilleries
Water (as steam) required for distillation	2-2.5	2.25	Data from 10 distilleries and literature & energy balance calculations
<b>NON-PROCESS APPLICATION</b>			
<b>Cooling water for:</b>			
a) Fermenter	1-2	1.5	Data from 10 distilleries; wide variation probably due to different ambient temperature at distillery location
b) Condensers	5-10	7.5	
Treated water for	1-2 m <sup>3</sup> /case	1.5	Figures could not be given in of

Use	m <sup>3</sup> of rectified spirit produced (Range)	Average	Basis & Remarks
making IMFL and for Boiler use			rectified spirit due to varied product mix of the distilleries
Wash water	0.1-0.2/case	0.15	
Water (as steam) for sterilizing vessels	0.15	0.15	Based on data collected from 15 distilleries

The material balance for one kL RS batch process of the distillery unit is illustrated in the following Table 3-3.

**Table 3-3: Material Balance for One kL of Rectified Spirit (Batch process)**

Raw material (MT)			Products/waste (MT)		
Input	Continuous	Batch	Output	Continuous	Batch
Molasses	3.57	4.237	RS (1.0 kL)	0.789	0.789
Dilution Water	8.0	12.267			
Steam	2.2	2.50	Spent wash Continuous Batch	10.40	15.60
Yeast	Nil	0.00258	10.0 kL 15.0 kL		
Urea	0.00050	0.00057	Spent Lees	1.50	1.70
Antifoam	0.00080	0.00087	Fermenter washings	0.05	0.15
Fermenter Washings	0.05	0.15	Yeast sludge	0.01	0.0375
Fermenter Cooling Water	0.2	0.2	CO <sub>2</sub>	0.754	0.754
	14.0213	19.3580		13.503	19.0305
				Balance = 0.5183 MT	Balance = 0.1275 MT

### Wastewater

The major sources of wastewater for molasses based distilleries are:

- Process waste streams
  - Spent wash from the analyser column
  - Fermenter sludge
  - Spent lees from the rectifier
- Non-process waste streams

- Cooling water
- Waste wash water
- Water treatment plant wastewater
- Boiler blow down
- Bottling plant wash wastewater
- Other wastes

Table 3-4 gives the process waste streams quantity for 16 distilleries. Also indicated in the table is whether the spent lees is recycled or not. A typical analysis of spent wash with ranges is indicated in Table 3-5, and Table 3-6 gives a typical analysis of the fermenter sludge.

**Table 3-4: Process Stream Discharge from Distilleries Based on Molasses**

S.No	Manufacturing Process	Unit	Fermenter Sludge	Spent wash	Spent leese
1.	Batch	kL per kL R.S	0.03	14 - 15	1 – 1.5
2.	Continuous	kL per kL R.S	0.01 -0.015	10 -12	1 – 1.5
3.	Biostill	kL per kL R.S	0.005 – 0.008	07 - 09	0.5 – 1.0

Note:

*Spent leese are recirculated depending on the end use of R.S*

**Table 3-5: Characteristics of Spent Wash**

S. No.	Characteristics	Range
1	pH	4.3-5.3
2	Total Solids	60,000-90,000
3	Total Suspended Solids (TSS)	2,000-14,000
4	Total Dissolved Solids (TDS)	67,000-73,000
5	Total Volatile Solids (TVS)	45000-65000
6	COD	70000-98000
7	BOD	45000-60000
8	Total Nitrogen as (N)	1000-1200
9	Potash as (K <sub>2</sub> O)	5000-12000
10	Phosphate as (PO <sub>4</sub> )	500-1500
11	Sodium as (Na)	150-200
12	Chlorides as (Cl)	5000-8000
13	Sulphates as (SO <sub>4</sub> )	2000-5000
14	Acidity as (CaCO <sub>3</sub> )	8000-16000
15	Temperature (After Heat Exchange)	70°C-80°C
Source: COINDS for Fermentation Industry, CPCB		

**Table 3-6: Important Components of Dried Fermenter's Sludge**

S.No.	Item	Content (% by Weight)
1	Moisture Content at (100°C)	4.14
2	Protein Content as (6.25 x N)	12.54
3	Acid Insoluble Matter	3.93
4	Mixed Oxide of Iron & Aluminum as (R <sub>2</sub> O <sub>3</sub> )	1.23
5	Calcium Carbonate as (CaCO <sub>3</sub> )	8.89
6	Calcium Sulphate as (CaSO <sub>4</sub> )	40.02
7	Calcium Phosphate as (Ca <sub>3</sub> (P <sub>0</sub> ) <sub>4</sub> ) <sub>2</sub> )	1.10
8	Magnesium Salts	Traces
9	Sodium Sulphate (Na <sub>2</sub> S <sub>0</sub> ) <sub>4</sub> )	0.57
10	Potassium Sulphate (K <sub>2</sub> S <sub>0</sub> ) <sub>4</sub> )	0.61

The total volume of wastewater discharged is about 90 kL/kL of RS produced where cooling water base is once through. Whereas the total volume of wastewater where cooling water is recycled is of the order of 47 kL/kL of RS produced. Figure 3-2 gives the water material balance for a typical distillery based on molasses. Table 3-7 gives quantity of wastewater for different processing units of a molasses based distillery.

**Table 3-7: Quantity and Characteristics of Process Wastewater**

S. No.	Source	Flow in kL/kL of RS		BOD	SS		Type of Flow
			mg/L	kg/kL of RS	mg/L	kg/kL of RS	
1	Spent Wash from Analyzer Column	10.0	5000 0	500	12000	120	Continuous
2	Fermenter Sludge	0.05	1250 00	6.25	50000	2.5	Intermittent
3	Spent Lees from Rectifier	1.0	500	0.50	16000	16.0	Continuous (Recycled)
4	Fermenter Cooling Water	2.0	100- 200	0.40	500	1.0	
5	Wash Water Fermenter		(350 0 as)				
6	Condenser Cooling Water						
	Not Recycled	50.0	-	-	-	-	-do-
	Recycled	2.5	-	-	-	-	Intermittent
7	Boiler Slowdown	0 15	-	-	-	-	-do-
8	Water Treatment plant	2. 1	-	-	-	-	-do-
9	Bottling Plant Wash water	2.8	100	0.28	200	0.56	Continuous

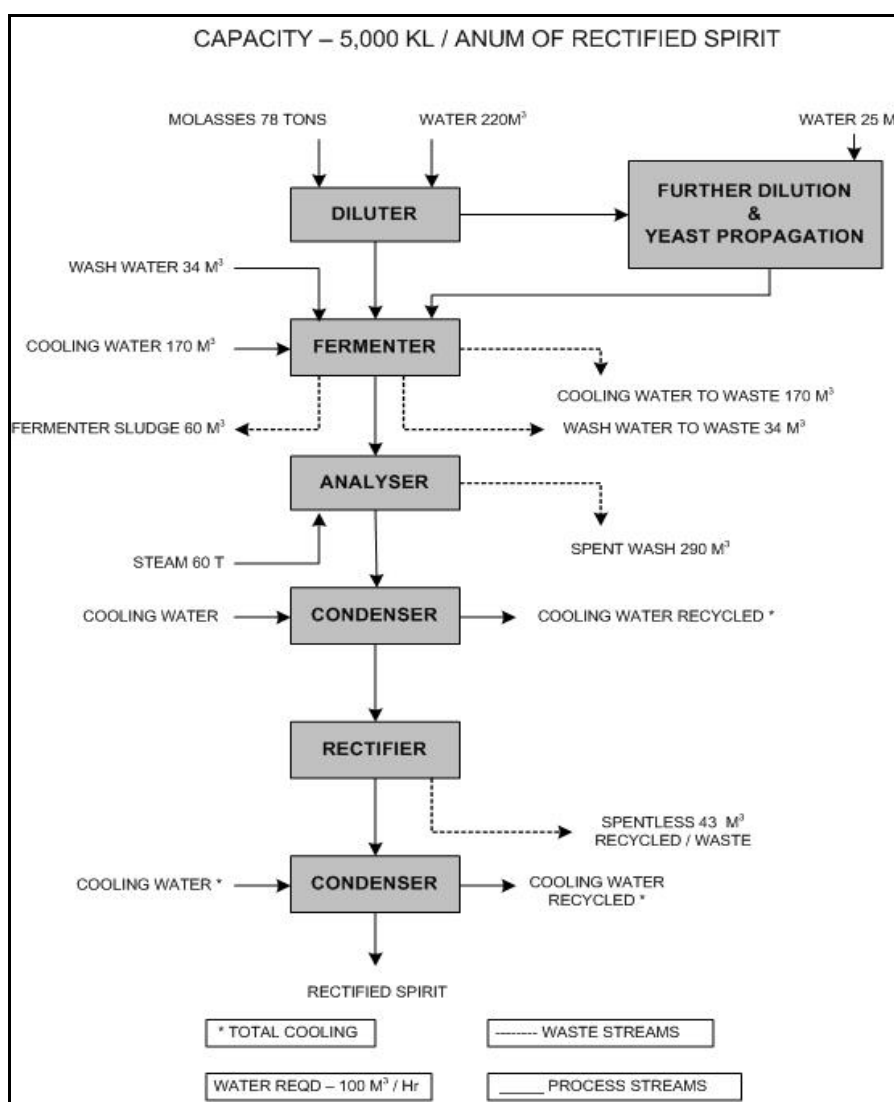

Figure 3-2: Water Balance for a Distillery - Model Case

### 3.4 Process of Distilleries Based on Molasses

#### 3.4.1 Alcohol

In India, alcohol is manufactured by two processes:

- Batch process
- Continuous process

##### a) Batch process

The molasses obtained from the sugar industry is first diluted to bring down the concentration of sugar from 40–45% to 10–15%. Using a portion of the diluted molasses a yeast culture is developed from an inoculum. After 4 - 6 hours, when the culture has developed fully, the remaining molasses is mixed and allowed to ferment for 30–40 hours. The pH is maintained around 4-4.5 by addition of sulphuric acid. As the reaction is exothermic, the contents of the fermentation tank are kept at 35-37°C by constantly sprinkling cold water on the outer surface of the fermentation tank.

After fermentation is complete the yeast sludge is removed from the bottom and the fermenter wash is pumped to the analyzer column for distillation using steam. The mixture of alcohol vapours and steam is collected at the top of the column and alcohol-free spent wash is discharged from the bottom.

The alcohol and the steam stream are fed to rectification column where water and alcohol vapours condense at different levels and rectified spirit is withdrawn. The condensed water from this stage is called spent lees and forms another waste stream.

### b) Continuous process

In this process yeast is recycled. Fermentation and distillation is coupled to get a continuous supply of fermented beer for the distillation column. The advantage of the process is that a highly active yeast cell initiates the fermentation rapidly and the alcohol yield is also much higher compared to the batch process.

Bio-still process is one of the continuous processes, which is a trade name in which molasses is fed to the fermenter at a constant flow rate. The flow rate of molasses is controlled to maintain the sugar and alcohol concentrations in the wash at 0.2% or lower and 6-7% respectively.

The waste streams comprise spent wash which is the main source of wastewater, spent lees and yeast sludge. Spent lees is usually mixed with the spent wash. The yeast sludge is disposed separately after drying. In addition wastewater may be generated from the bottling, fermentation tank cooling and washing and utility sections of the plant, which is used as a diluent for the treated spent wash,

The following Table 3-8 gives the characteristics of spent wash generated from the three types of manufacturing processes. It is seen that while the spent wash generated per litre of alcohol production is less when continuous and Bio-still processes are used. In comparison to these two, the spent wash produced from the Batch processes is more concentrated.

**Table 3-8: Characteristics of Spent Wash from Various Types of Manufacturing Process**

S.No	Parameter	Batch Process	Continuous Process	Bio-still Process
1	Volume, L/L alcohol	14 – 15	10 – 12	7 – 9
2	Color	Dark brown	Dark brown	Dark brown
3	pH	3.7 – 4.5	4.0 – 4.3	4.0 – 4.2
4	COD	80000-100000	110000 – 130000	140000 – 160000 mg/L
5	BOD	45000 – 50000	55000 – 65000	60000 – 70000 mg/L
6	Solids			
	Total	90000 – 120000	130000 - 160000	160000 – 210000 mg/L
	Total volatile	60000 – 70000	60000 – 75000	80000 – 90000 mg/L
	Inorganic dissolved	30000 – 40000	35000 – 45000	60000 – 90000 mg/L
7	Chlorides	5000- 6000	6000 – 7500	10000 – 12000 mg/L
8	Sulphates	4000 – 8000	4500 – 8500	8000 – 10000 mg/L
9	Total Nitrogen	1000 – 1200	1000 – 1400	2000 – 2500 mg/L
10	Potassium	8000 – 12000	10000 – 14000	20000 – 22000 mg/L



11	Phosphorous	200 – 300	300 – 500	1600 – 2000 mg/L
12	Sodium	400 – 600	1400 – 1500	1200 – 1500 mg/L
13	Calcium	2000 – 3500	4500 – 6000	5000 – 6500 mg/L

Source: Draft report prepared on “Development of Methodology for Environmental Auditing” by Dr. B. Subba Rao of EPRF, Sangli, for CPCB.

The spent lees obtained from the bottom of the rectification column after separation of alcohol is about 2% of the spent wash, the characteristics of spent lees is given in the following Table 3-9.

**Table 3-9: Characteristics of Spent Lees**

S.No	Parameter	Range
1	pH	3.6 – 4.5
2	COD	5000 - 6000 mg/L
3	BOD	200 – 300 mg/L
4	Total Solids	
	Dissolved Solids	5000 – 6000 mg/L
	Suspended Solids	500 – 1000 mg/L
5	Chlorides	50 – 100 mg/L

Source: Draft report prepared on “Development of Methodology for Environmental Auditing” by Dr. B. Subba Rao of EPRF, Sangli, for CPCB

### 3.4.2 Rectified spirit

Molasses-based distilleries are more common in India. The main process steps in this operation are graphically shown in Figure 3-3 and listed below. However, the detailed description of the manufacturing process for rectified spirit is given in **Annexure I**.

- Dilution - Preparation of molasses for fermentation
- Fermentation - Production of alcohol from fermentable sugars in molasses solution
- Distillation - Product recovery

#### Dilution

Molasses available from Indian sugar mills has a solid content varying between 76 and 90% while the total sugar content varies between 45 and 55%.

The main dilution operation occurs in a diluter where the solid concentration is brought down to 20-25° Brix. The bulk of this diluted molasses is fed to the fermentation tank while a small quantity is further diluted to 10-15° Brix and used for preparation of the final yeast inoculum. Propagation of yeast for the final inoculation is done in successive stages in volumes of 10, 100, 1000 and 10,000 litres where, in each stage, 10 parts of diluted molasses is inoculated with 1 part of yeast culture.

#### Fermentation

Fermentation in the fermentation tank continues for about 30 to 45 hours after the final inoculum is added to it. The basic reaction in the fermentation process is exothermic.

Since the reaction is exothermic and proper growth of yeast requires a narrow temperature range, water is sprayed on the outer walls of the fermentation tank to maintain the temperature between 25°C and 32°C.

Fermented beer – the main product of this step is decanted and the remaining sludge known as fermenter sludge is discharged from the bottom of the fermenters. The sludge amounts to about 300 to 400 litres (l) per kilolitre (kL) of rectified spirit produced, and is one of the major contributors to the pollution load from distilleries.

### Distillation

The fermented beer from the fermenter vessel is preheated to about 90°C by heat exchange with the spent wash flow from the analyzer column and is then fed into the degasifying section of the analyzer column. Low boiling content of the fermented beer such as organic acids, esters and aldehydes along with some alcohol vapours are condensed in the aldehyde condensers. Purified wash from the bottom of the degasifying section enters the top of the analyzer column for steam stripping of alcohol which condenses at the top of the column as 40% alcohol. The down coming discharge from this column is spent wash.

The 40% alcohol stream from the top of the analyzer column is next fed to the bottom of the rectification column where it is maintained at a temperature of about 95° to 100°C. Water and alcohol vapour condense at different levels in this column and rectified spirit of an equilibrium boiling composition (95%) is withdrawn. Of this rectified spirit, a part is fed back into the column. Spent lees, produced at this step are usually pumped back to the analyzer column. The volume of spent lees is about 1-1.5 kL/kL of rectified spirit produced.

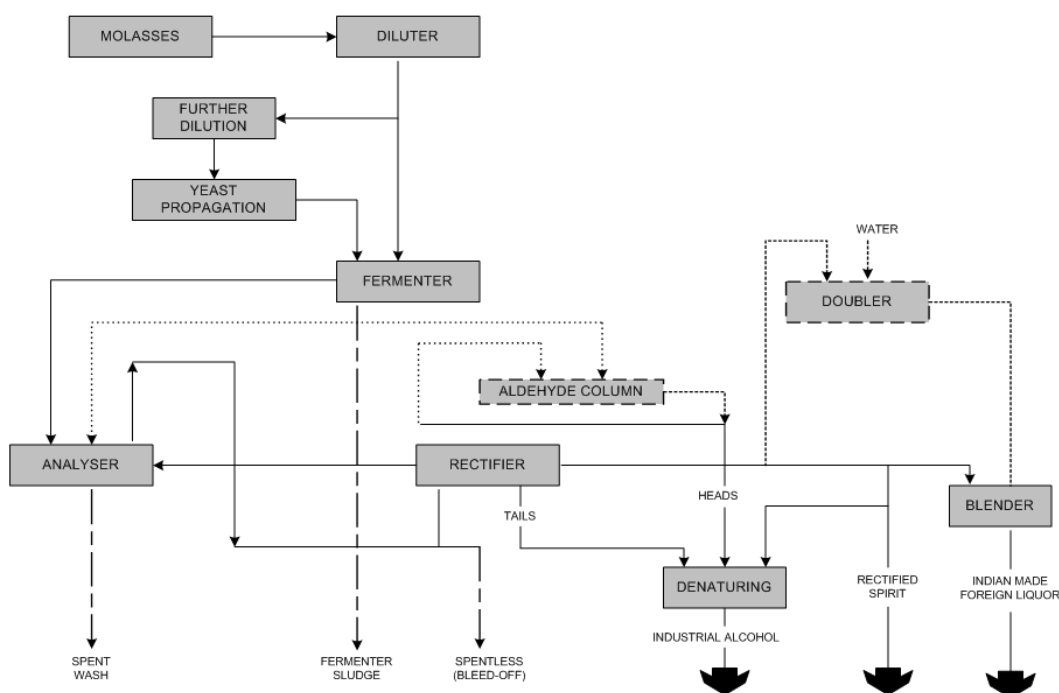
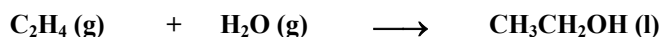

Figure 3-3: Process Block Diagram of Distillery (Molasses Based)

### 3.5 Ethanol

Ethanol is produced both as a petrochemical, through the hydration of ethylene, and biologically, by fermenting sugars with yeast. Determining the most economical among the products depends upon the prevailing prices of petroleum and of grain feedstock. This EIA manual focuses on the fermentation process of alcohols production. Summary of both the processes is given below.

**Ethylene Hydration:** Ethanol for use as industrial feedstock is most often made from petrochemical feedstock, typically by the acid-catalyzed hydration of ethylene, represented by the chemical equation



The catalyst is most commonly phosphoric acid, adsorbed onto a porous support such as diatomaceous earth or charcoal. This catalyst was first used for large-scale ethanol production by the Shell Oil Company in 1947. The reaction is carried out with an excess of high pressure steam at 300°C.

In an older process, first practiced on the industrial scale in 1930 by Union Carbide, but now almost entirely obsolete, ethylene was hydrated indirectly by reacting it with concentrated sulphuric acid to produce ethyl sulfate, which was then hydrolyzed to yield ethanol and regenerate the sulfuric acid:

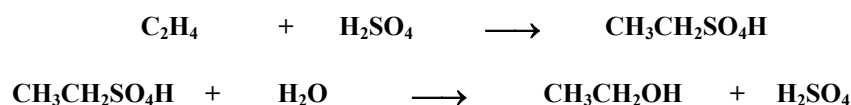

**Ethanol by Fermentation:** Ethanol for use in alcoholic beverages, and the vast majority of ethanol for use as fuel, is produced by fermentation. When certain species of yeast (*e.g.*, *Saccharomyces cerevisiae*) metabolize sugar in the absence of oxygen, they produce ethanol and CO<sub>2</sub>. The chemical equation below summarizes the conversion:

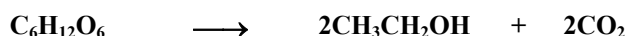

Ethanol's toxicity to yeast limits the ethanol concentration obtainable by brewing. The most ethanol-tolerant strains of yeast can survive up to approximately 15% ethanol by volume.

The fermentation process must exclude oxygen. If oxygen is present, yeast undergoes aerobic respiration which produces CO<sub>2</sub> and water rather than ethanol.

In order to produce ethanol from starchy materials such as cereal grains, the starch must first be converted into sugars. In brewing beer, this has traditionally been accomplished by allowing the grain to germinate, or malt, which produces the enzyme, amylase. When the malted grain is mashed, the amylase converts the remaining starches into sugars. For fuel ethanol, the hydrolysis of starch into glucose can be accomplished more rapidly by treatment with dilute sulphuric acid, fungally produced amylase, or some combination of the two.

### 3.5.1 Cellulosic ethanol

Sugars for ethanol fermentation can be obtained from cellulose. Until recently; however, the cost of the cellulose enzymes capable of hydrolyzing cellulose has been prohibitive. The Canadian firm Iogen brought the first cellulose-based ethanol plant on-stream in 2004. Its primary consumer so far has been the Canadian government, which, along with the United States Department of Energy, has invested heavily in the commercialization of cellulosic ethanol. Deployment of this technology could turn a number of cellulose-containing agricultural by-products, such as corncobs, straw, and sawdust, into renewable energy resources. Other enzyme companies are developing genetically engineered fungi that produce large volumes of cellulase, xylanase, and hemicellulase enzymes. These would convert agricultural residues such as corn stover, wheat straw, and sugarcane bagasse and energy crops such as switch grass into fermentable sugars.

Cellulose-bearing materials typically also contain other polysaccharides, including hemicellulose. When hydrolyzed, hemicellulose decomposes into mostly five-carbon sugars such as xylose. *S.cerevisiae*, the yeast most commonly used for ethanol production, cannot metabolize xylose. Other yeasts and bacteria are under investigation to ferment xylose and other pentoses into ethanol.

The anaerobic bacterium *Clostridium ljungdahlii*, recently discovered in commercial chicken yard wastes, can produce ethanol from single-carbon sources including synthesis gas, a mixture of carbon monoxide (CO) and hydrogen that can be generated from the partial combustion of either fossil fuels or biomass. Use of these bacteria to produce ethanol from synthesis gas has progressed to the pilot plant stage at the BRI Energy facility in Fayetteville, Arkansas.

Another prospective technology is the closed-loop ethanol plant. Ethanol produced from corn has a number of critics who suggest that it is primarily just recycled fossil fuels because of the energy required to grow the grain and convert it into ethanol. There is also the issue of competition with use of corn for food production. However, the closed-loop ethanol plant attempts to address this criticism. In a closed-loop plant, the energy for the distillation comes from fermented manure, produced from cattle that have been fed the by-products from the distillation. The leftover manure is then used to fertilize the soil used to grow the grain. Such a process is expected to lower the fossil fuel consumption used during conversion to ethanol by 75%. Although energy can be created from the collection of methane from livestock manure, this can be mutually exclusive to the production of ethanol and should not be tagged on to it to make ethanol production seem more efficient or environmentally friendly.

Though, in an early stage of research, there is some development of alternative production methods that use feedstock such as municipal waste or recycled products, rice hulls, sugarcane bagasse, small diameter trees, wood chips, and switch grass.

### 3.5.2 Grades of ethanol

**Denatured Alcohol:** Pure ethanol and alcoholic beverages are heavily taxed, but ethanol has many uses that do not involve consumption by humans. To relieve the tax burden on these uses, most jurisdictions waive the tax when an agent has been added to the ethanol to render it unfit to drink. These include bittering agents such as denatonium benzoate and toxins such as methanol, naphtha, and pyridine. Products of this kind are called denatured alcohol.

**Absolute Ethanol:** Absolute or anhydrous alcohol generally refers to purified ethanol, containing no more than 1% water. Absolute alcohol not intended for human consumption often contains trace amounts of toxic benzene (used to remove water by azeotropic distillation). Consumption of this form of ethanol can be fatal over a short time period. Generally this kind of ethanol is used as solvents for lab and industrial settings where water will disrupt a desired reaction.

**Pure ethanol:** This is classed as 200 proof in the USA, equivalent to 175° proof in the UK system.

### 3.5.3 Sequence of steps for production of ethanol

Ethanol is the final end product of three processes namely

- Fermentation Process
- Distillation Process and
- Dehydration Process

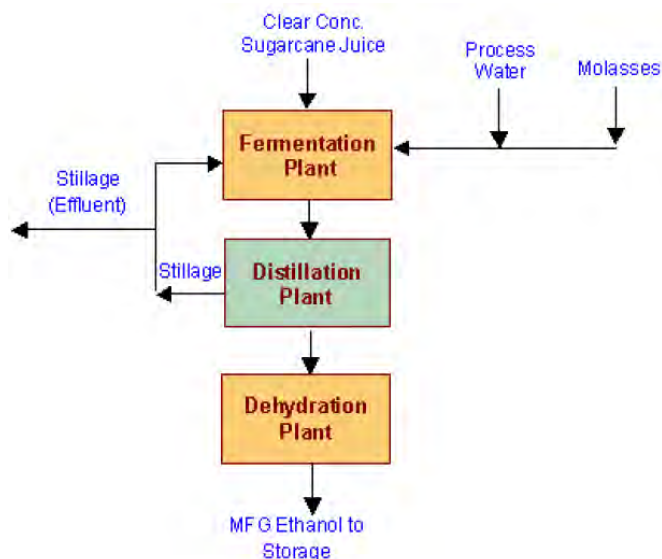

Figure 3-4: Block Flow Diagram of Ethanol Plant

#### A. Fermentation process

Ethanol can be made by the fermentation of sugars. Simple sugars such as sugarcane juice or molasses are the raw material. Zymase, an enzyme from yeast, changes the simple sugars into ethanol and CO<sub>2</sub>. The enzymatic reaction carried over by the yeast in fermentation produces mainly ethanol, CO<sub>2</sub> and heat. The fermentation reaction is actually very complex. The impure culture of yeast produces varying amounts of other substances, including glycerin, methanol and various organic acids.

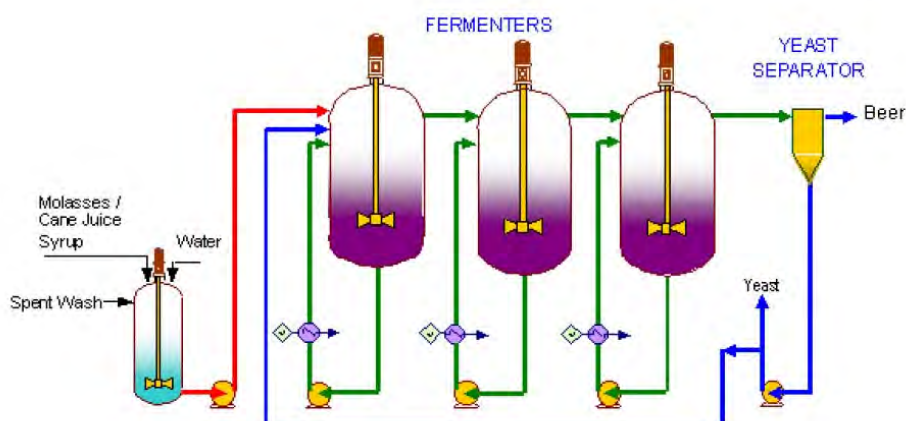

Figure 3-5: Preliminary Process Flow Sheet Depicting Fermentation of Molasses

### B. Distillation process

Ethanol produced by fermentation ranges in concentration from a few percent up to about 14 percent; the rest being water and other components. The boiling point of ethanol (78.4°C) is significantly lower than the boiling point of water (100°C). These materials cannot be separated completely by distillation. Instead, an azeotropic mixture (*i.e.* a mixture of 96% ethanol and 4% water) is obtained. Azeotropic mixture of alcohol cannot be further concentrated by distillation. Distillation is used to produce Rectified Spirit (RS).

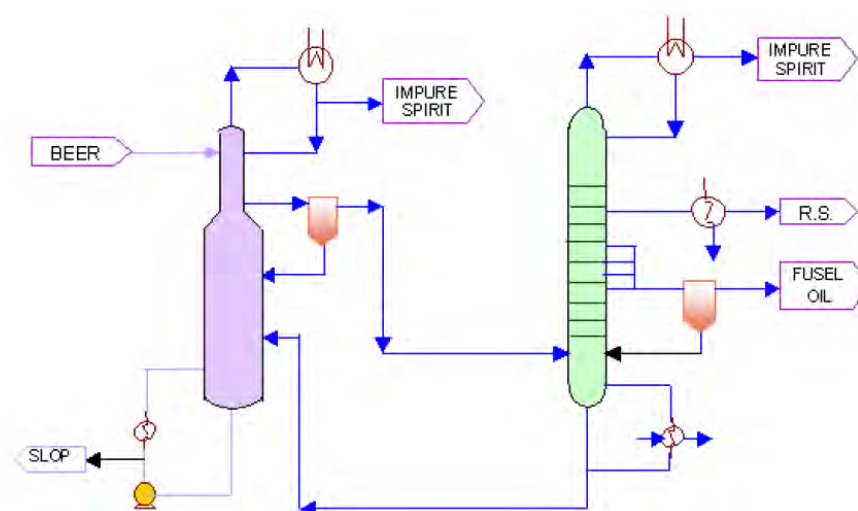

Figure 3-6: Process Flow Sheet Depicting Distillation of Ethanol

### C. Dehydration of alcohol

Pure alcohol can't be obtained from distillation since it forms azeotrope with water at 96% (v/v). Fuel ethanol or absolute alcohol is produced by dehydration of RS. Commercially available technologies for dehydration of RS are:

- Azeotropic Distillation
- Molecular Sieve Technology

**i. Azeotropic distillation method**

To dehydrate ethanol from azeotropic concentration, a third substance called Entrainer (trichloro ethylene, benzene, toluene, cyclo-hexane *etc.*) is added to the mixture of ethanol and water. Entrainer breaks the azeotropic point of ethanol and water, *i.e.*, it alters the relative volatility of water making it more volatile. The ternary azeotropic mixture, formed at the top of dehydration column, allows the removal of water and thus dehydrates alcohol. The azeotropic mixture is heterogeneous and the ‘heavy’ phase, which is high in water content, is extracted by decantation. The regeneration column allows water extraction from the ‘heavy’ phase and entrainer recycling

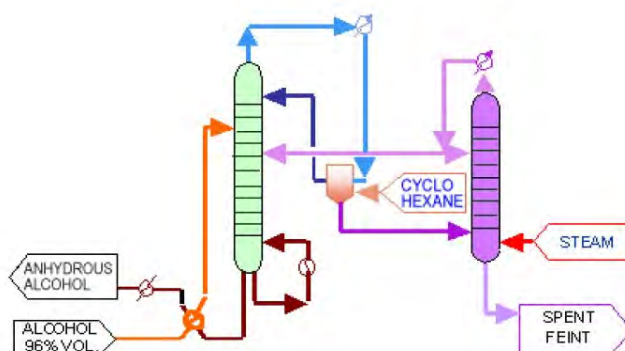

**Figure 3-7: Process Flow Sheet Depicting Azeotropic Distillation Process**

**ii. Molecular sieve technology**

Molecular sieve technology works on the principle of Pressure Swing Adsorption (PSA). Here water is removed by adsorption on surface of ‘molecular sieves’ under pressure and then cyclically removed it under low pressure at different conditions. This process carries out dehydration of mixed ethanol and water by adsorption of water into zeolite balls, which are molecular sieves. The dehydration unit operates with two adsorbers according to alternate steps of adsorption and desorption. Adsorption occurs in the vapour phase and under pressure. Desorption regenerates water saturated molecular sieves. This step is performed under vacuum. Part of the dehydrated alcohol is used for the molecular sieve desorption. Alcoholic effluent from desorption is regenerated within the distillation column.

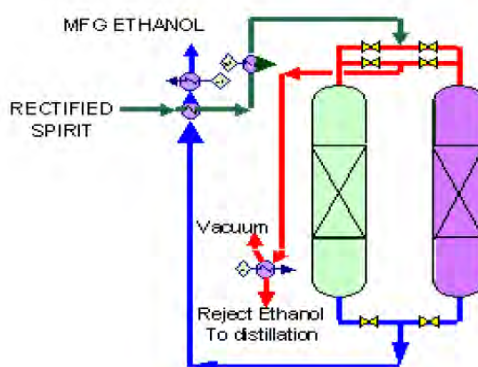

**Figure 3-8: Process Flow Sheet Depicting Molecular Sieve Dehydration Process**

*Optimum Energy Utilization; Enhancement in Plant capacity; Fully automatic operation*

### 3.6 Raw Material Inputs in the Production Line

The fermentation industry includes the production of malt beverages (beer); wines; brandy and brandy spirits; distilled spirits; and the secondary products of all of these industries. The most commonly produced distilled spirits for beverage purposes include whiskies, gins, vodkas, rums, and brandies.

#### 3.6.1.1 Raw materials of alcoholic beverages

The names of some beverages are determined by the source of the material fermented. In general, a beverage fermented from a starch-heavy source (grain or potato), in which the starch must first be broken down into sugars (by malting, for example), will be called a beer; if the mash is distilled, the product is a spirit. Wine is made from fermented grapes.

##### Grains

Brandy and wine are made only from grapes. If an alcoholic beverage is made from another kind of fruit, it is distinguished as fruit brandy or fruit wine. The variety of fruit must be specified, *viz.* 'cherry brandy' or 'plum wine.'

Beer is generally made from barley, but can sometimes contain a mix of other grains. Whisky (or whiskey) is sometimes made from a blend of different grains, especially Irish whisky which may contain several different grains. The style of whisky (scotch, rye, bourbon, corn) generally determines the primary grain used, with additional grains usually added to the blend (most often barley, and sometimes oats). As far as American whisky is concerned, bourbon (corn), and rye whisky, must be at least 51% of respective constituent at fermentation, while corn whisky (as opposed to bourbon) must be at least 81%—all by American law similar to the French AOC (*Appellation d'Origine Contrôlée*).

Two common distilled beverages are vodka and gin. Vodka can be distilled from any source of agricultural origin (grain and potatoes being the most common), but the main characteristic of vodka is that it is so thoroughly distilled as to exhibit less of the flavours derived from its source material. Some distillers and experts; however, may disagree, arguing that potato vodkas display a creamy mouth feel, while rye vodkas will have heavy nuances of rye. Other vodkas may display citrus notes. Gin is a similar distillate, which has been flavoured by contact with herbs and other plant products—especially juniper berries, but also including angel root, licorice, cardamom, grains of paradise, Bulgarian rose petals, and many others.

Applejack is an example of a drink originally made by freeze distillation, which is easy to do in cold climates. Although both distillation and freeze distillation reduce the water content, they are not equivalent, because freeze distillation concentrates poisonous higher.

#### 3.6.1.2 Raw materials for brewing industry

Resources consumed by the brewing industry include water, energy and grist materials (barley, corn and rice), adjuncts and auxiliary materials such as Kieselguhr, caustic soda and detergents. Adjuncts are used to reduce the costs of production, to adjust the balance in the composition of the wort, and to produce (if desired) a 'lighter' beer (UNEP, 1995).

The production of one hectolitre of normal lager beer requires about 15 kilograms (kg) of malt and adjunct. The adjunct content does not exceed 30% of the brewing material.



Hops are added to the beer to give it a bitter taste and a pleasing aroma. It can be added in the form of natural hops, or more commonly, as hop extract or powder.

## Water

Brewing is a water-intensive process and large amounts of water are consumed in the production of beer and wine for the following processes:

- Cooling
- Cleaning of packaging material (*e.g.*, bottle washing)
- Pasteurization
- Rinsing and cleaning of process equipment
- Steeping, mashing, sparging, *etc.* (typically 5 cubic metres (m<sup>3</sup>) of water is used to produce one tonne of malted barley)
- Cleaning of floors and equipment
- Soap lubricant on conveyors in the packaging area
- Vacuum pump for filler; and
- Flushing of filler

In a study of water and wastewater management in the breweries of South Africa, it was (BPCE, 1986) reported that the specific water intake (SWI) in the brewing process ranged from 5.5-8.8 m<sup>3</sup> of water per m<sup>3</sup> of beer produced, with a typical value of 6.65 m<sup>3</sup>/m<sup>3</sup>. A further breakdown of the usage into the main water-consuming areas is provided below.

Water consumption generally ranges from 4-10 hL /hL beer depending on the packaging and pasteurizing process, the age of the plant and the type of equipment. Furthermore, raw water temperature will affect water consumption, as water is often used as a cooling medium. A recent study at Heineken determined that breakdown of water use in a brewery (6.5 (hectoliter) hL/hL beer) was as follows (UNEP, 1995):

- Raw material 1.3 hL /hL
- Cleaning 2.9 hL /hL
- Cooling water 0.7 hL /hL
- Other (domestic, losses) 1.6 hL /hL

However, water consumption may amount to two to three times the above figures, especially where the raw water temperature is high (UNEP, 1995).

## Energy consumption

As far as energy is concerned heat consumption is influenced by process and production characteristics such as packing method, pasteurization technique, type of equipment, by-product treatment, *etc.* In a brewery (without a heat recovery system from boiling wort), heat consumption can be two to three times higher than a well run brewery. Electricity consumption, in a well run brewery, is about 8-12 kwh/hL, depending on process and production characteristics. Some breweries consume up to twice as much due to inefficient production and lack of energy consciousness (UNEP, 1995).

**Table 3-10: Benchmark for Energy Consumption**

Outputs per Unit of Product	Unit	Benchmark
Energy		

Heat	MJ/hL	85-120
Electricity	kWh/hL	7.5-11.5
Total Energy	MJ/hL	100-160

### Auxiliary materials

In addition to basic raw material used in beer production as surmised above there are auxiliary material used which are as follows:

- Kieselguhr is used for filtering beer at a rate of 100 - 300 g/hL depending on initial clarity, yeast cell count and beer type.
- Caustic soda is used for cleaning at 0.5-1.0 kg (30% NaOH)/hL. High consumption can be due to no or little recovery during equipment cleaning and to problems with the bottle washer. This increases the pH of wastewater.
- Detergents and acids may be used for cleaning. The consumption rate depends on the cleaning procedures.
- Packaging materials include non-returnable bottles, cans, crown corks, cardboard, plastic stretch and shrink wraps, *etc.* (UNEP, 1995).
- Other materials are used including glue (used for labels and cardboard boxes) and a range of additives such as enzymes, antioxidants, foam stabilizers and colloidal stabilizers (finings, silica, tannic acid, *etc.*).

## 3.7 Industrial Processes of Various Products of Distillery Industry

### 3.7.1 Manufacturing process of spirits (whisky, vodka & gin)

Different process units involved in Whisky manufacturing are summarized below.

#### A. Mashing

The mashing process consists of cooking (gelatinization) of the grain in water to solubilize the starches from the kernels and converting (saccharification) of the starch to 'grain sugar' (primarily glucose and maltose). In general, cooking can be carried out at or above atmospheric pressure in either a batch or continuous process. During mashing, trace Volatile Organic Compound (VOC) emissions may result from constituents in the grain. Small quantities of malted barley are sometimes added prior to grain cooking. After partial cooling, conversion of the starch to sugar is accomplished by adding barley malt and/or enzymes (from other sources) to the cooked grain at approximately 63EC (145EF). The mash then passes through a noncontact cooler to a fermenter. Between the mashing and fermentation, the process generally is closed during cooling, with no emissions. Distillers may vary mashing procedures, but generally conform to basic principles, especially in the maintenance of sanitary conditions.

#### B. Fermentation

Fermentation, which usually lasts 3 to 5 days for whisky, involves the use of yeast to convert the grain sugars into ethanol and CO<sub>2</sub>. The converted grain mash is cooled prior to entering the fermenter or tank and inoculated with yeast. It is a common practice to dilute the hot grain mash to its final solids concentration by adding backset stillage and/or

water. Backset is liquid stillage which is screened or centrifuged from the distillation 'beer still bottoms.' The use of backset provides water conservation, nutrient supplements, pH adjustment of the fermentation, and some flavor components (e.g., sour mash).

The fermentation process varies slightly for the production of other distilled spirits. For instance, rum fermentation takes 1 to 2 days. In rum production, black strap molasses is the source of fermentable sugars and is stored in tanks prior to fermentation. The black strap molasses also is not mashed (*i.e.*, cooked) prior to dilution with water to obtain the proper concentration of fermentable sugars. Congeners are flavor compounds which are produced during fermentation, as well as during the aging process. These congeners include trace aldehydes, esters, and higher alcohols (*i.e.*, fusel oils). Lactic acid bacteria (*Lactobacillus*) may simultaneously ferment within the mash and contribute to the overall whisky flavor profile. On rare occasions *Lactobacillus* may provide some pH control. On other occasions, the addition of sulphuric acid, though rarely used, may result in trace hydrogen sulphide emissions from the fermentation tank.

In whisky production, significant increases in the amount of yeast consumed occur during the first 30 hours of fermentation, when over 75% of the carbohydrate (sugar) is converted to ethanol and CO<sub>2</sub>. Many fermentation vessels are equipped with agitation and/or cooling means that facilitate temperature control. Fermentation vessels may be constructed of wood or metal and may be open or closed top.

### C. Distillation

The distillation process separates and concentrates the alcohol products from the fermented grain Mash and is an add-on unit for production of spirits and make the whisky production different from Beer and Wine. In addition to the alcohol and congeners, the fermented mash contains solid grain particles, yeast cells, water-soluble proteins, mineral salts, lactic acid, fatty acids, and traces of glycerol and other trace congeners. Distillation processes also include the continuous multicolumn extractive and rectifying systems, and the batch rectifying pot still and condensing unit. Whisky stills are usually made of copper, especially in the rectifying section, although stainless steel may be used in some stills.

In a general whisky distillation process using a beer still, the whisky separating column consists of a cylindrical shell having three sections: stripping, entrainment removal, and rectifying. The stripping section contains approximately 14 to 21 perforated plates, spaced 56 to 61 centimetres (cm) (22 to 24 inches) apart. The fermented mash is introduced at the top of the stripping section and descends from plate to plate until it reaches the base where the stillage is discharged. Steam is introduced at the base of the column, and the vapours from the bottom of the still pass up through the perforations in the plates. Whisky stills are usually fitted with entrainment removal sections that consist of a plate above the stripping plate to remove fermented grain particles entrained in the vapour. Distillation columns operate under reflux (sealed) conditions and most vapors are condensed and collected, although small amounts of non-condensable gases will be emitted to the atmosphere.

Following distillation, the whisky, at high proof, is pumped to stainless steel tanks and diluted with demineralized water to the desired alcohol concentration prior to filling into oak barrels.

The distillation of other spirits, such as rum, is similar.

#### D. Grain and liquid stillage

At most distilleries, after the removal of alcohol, still bottoms (known as whole stillage) are pumped from the distillation column to a dryer house. Whole stillage may be sold; land applied (with appropriate permitting), sold as liquid feed, or processed and dried to produce distiller dried grains (DDG). The DDG consists of proteins, fats, minerals, vitamins, and fibers which are concentrated threefold by the removal of the grain starch in the mashing and fermentation process. Distillers' secondary products are divided into four groups: DDG, distiller dried solubles (DDS), DDG with solubles (DDG/S), and condensed distiller solubles (CDS).

Solids in the whole stillage are separated using centrifuges or screens. The liquid portion 'thin stillage' may be used as a backset or may be concentrated by vacuum evaporation. The resultant syrup may be recombined with the solid portion or dried separately. This remaining mixture is then dried using one of a variety of types of dryers (usually steam-heated or flash dryers). The majority of DDG are used in animal feed, although increasing quantities are being sold as food ingredients for human consumption due to its nutrient and fiber content.

#### E. Warehousing/aging

Newly distilled whisky is colorless with a strong, harsh and unpalatable odor. The new whisky distillate undergoes many types of physical and chemical changes in the aging process that impart the distinctive color, taste and aroma of the whisky and gives it character. These changes include extraction of the wood compounds, decomposition and diffusion of the wood macromolecules into the alcohol, reactions of the wood and distillate compounds with each other, and oxidation produced by diffusion to ambient atmosphere.

During the aging, both the charred oak barrel in which beverage alcohol is stored and the barrel environment are key to producing distilled spirits of desired quality and uniqueness. The aging process gives whisky its characteristic color and distinctive flavor and aroma. Variations in the aging process are integral to producing the characteristic taste of a particular brand of distilled spirits. Aging practices may differ from distillate to distiller, and even for different products of the same distiller. Figure 3-9 shows a simplified illustration of the mechanisms of the whisky aging process.

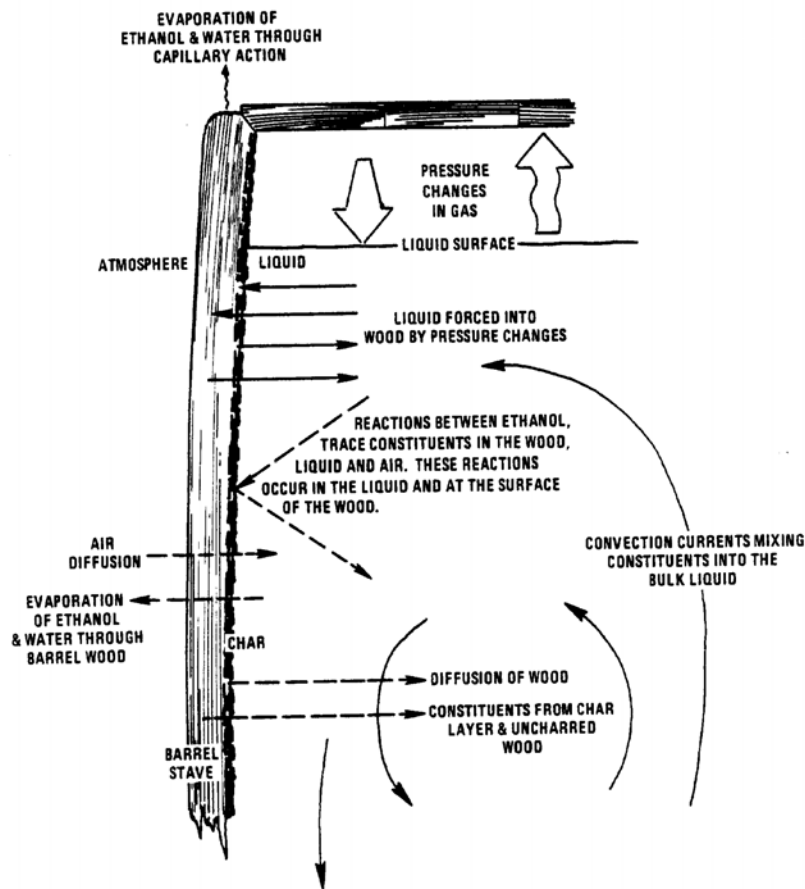

**Figure 3-9: Mechanism of Whisky Aging Process**

Ambient atmospheric conditions, such as temperature and humidity, as well as seasonal variation, are important factors in the aging process. Aging practices vary considerably—some distillers, for example, keep their warehouse windows open during certain months to promote interaction of the aging whisky with outdoor atmospheric conditions. An EPA report observed that the aging process, in particular, depends upon the interaction of whisky in oak barrels with ambient air and particularly the temperature, humidity, and ventilation promoted by the different types of warehouse construction utilized in the industry. While each distiller alters the barrel environment to produce a product with the distinctive characteristics of its brand, the fundamentals of the natural aging process are inviolate. The various distillers control the barrel environment differently by operating their warehouses in different manners. All of these variations illustrate the number of differing aging philosophies and traditions. Ethanol emissions are a natural and integral consequence of creating the distinctive qualities of various whisky production and aging embodied in the federal law.

When whisky ages, the alcohol reacts with constituents in the barrel wood, producing its distinctive color, taste and aroma. Constituents in the wood are transferred to the bulk liquid in the barrel by simple diffusion, by convection currents in the bulk liquid, and by temperature cycling. As the barrel heats up, the gas above the liquid increases in pressure and forces liquid into the barrel wood. When the barrel cools and the gas pressure drops, the liquid flows out of the wood into the bulk liquid, carrying wood constituents with it. The distinctive qualities of whisky are added during aging as trace substances called congeners which occur through:

- extraction of organic substances from the wood and their transfer to the whisky,
- oxidation of the original substances and of the extracted wood material, and
- reaction between various organic substances present in the liquid to form new products. The amber color develops and the taste of the whisky mellows during aging as the concentration of congeners increases.

Similar reactions between the barrel liquid and barrel constituents characterize aging of other distilled spirits, such as brandy and rum.

#### **F. Blending/bottling**

After whisky aging is complete, it is dumped or pumped from barrels into stainless steel tanks and reduced in proof to the desired alcohol concentration by adding demineralized water. The diluted whisky is processed and filtered. Following a filtration process the whisky is pumped to a tank, proof adjusted, and bottled.

Due to their value and marketability, used barrels are not generally stored but either refilled with other whiskies or bung sealed and sold to manufacturers of Scotch Whisky, Canadian Whisky, rum, brandy, Tequila, or wines.

New bottles are unloaded from cases and put on a conveyor belt, where they are air cleaned, filled, capped, and labeled. At the end of the conveyor belt, the final product is put into cases, which are sealed, labeled, and shipped to distributors.

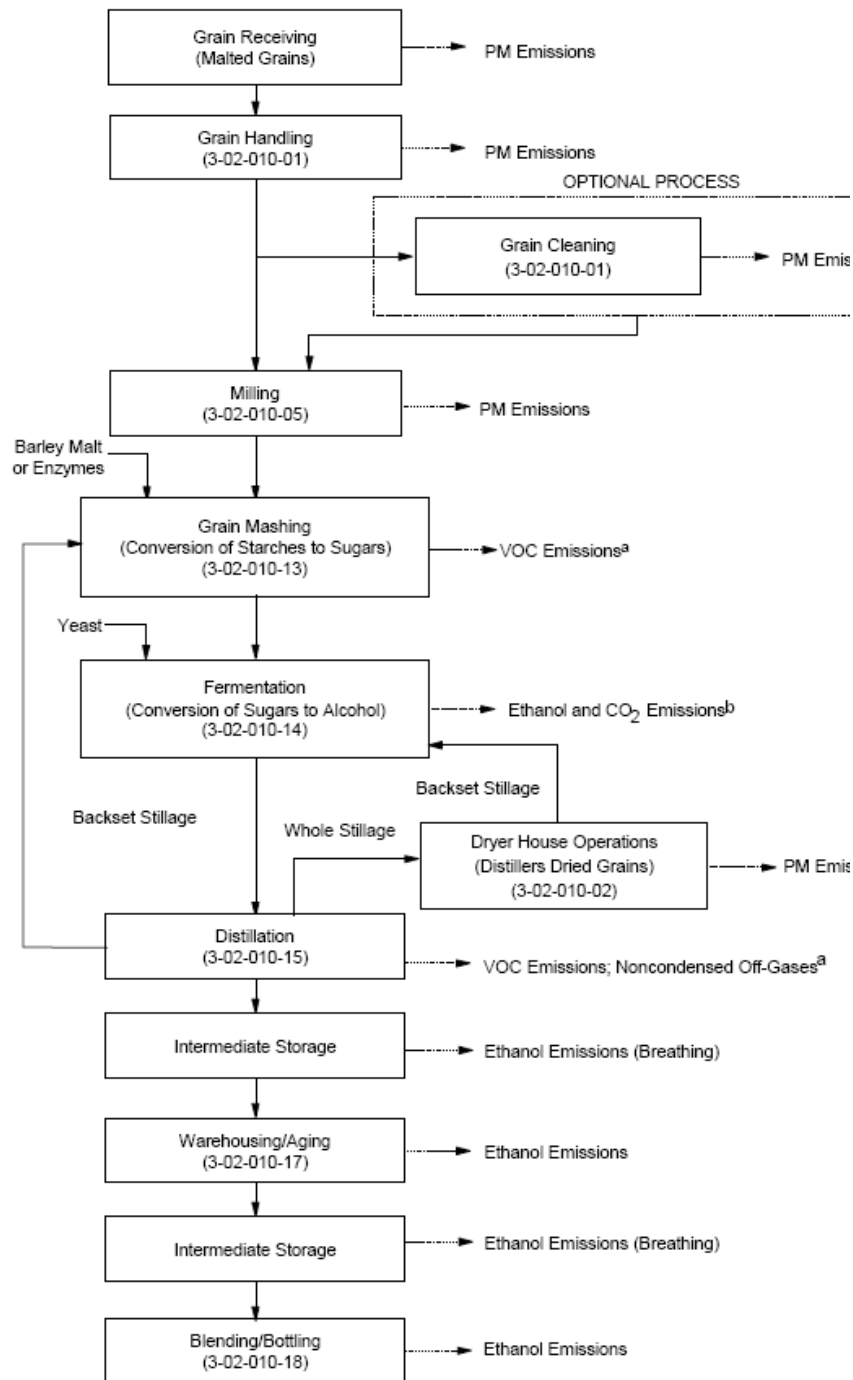

Figure 3-10: Process Flow Sheet Depicting Whisky Production

### 3.7.2 Gin manufacturing process

Gin can be made from any neutral spirit alcohol - the base can be grain (normally barley and maize) or molasses and has no flavor at all. As with the production of beer, the base starch is mixed with water, heated, cooled, and allowed to ferment.

The wash so produced is then distilled to an alcohol content of 95% ABV. This is then diluted to strength of about 45% ABV and left to steep with flavoring botanicals (famously juniper but others may include citrus peel, various spices and angelica). The

liquid is then heated in a still and, as with whisky, only the middle portion is used. The foreshots and feints are returned for distillation with the next batch. Finally the spirit is diluted to reach the required minimum alcohol content (37.5% ABV) and then bottled.

Cheaper gins can be made by simply adding essential oils to the diluted neutral spirit alcohol. This 'cold compounded' gin cannot be called distilled.

### 3.7.3 Vodka manufacturing process

The starting point for vodka is, as with gin, a neutral spirit. In the EU the spirit is usually produced from grain (wheat, barley, maize, rye) or molasses. In the Eastern Europe it may also be made from potatoes, or rice.

As with gin, the wash is usually distilled twice although many vodkas are triple distilled, some even more. The distillate is diluted to an ABV of about 55% before it is filtered, usually through charcoal. Sometimes coagulants are used to bind impurities so that they can be filtered out more readily. Finally, more water is added to give the vodka the minimum ABV (legal EU Standard) of at least 37.5%. At this stage some producers include additives while others may introduce flavouring such as natural essences or fruits or herbs which are steeped in the vodka for several days. No maturation period is required.

### 3.7.4 Brandy manufacturing process

Brandy is made from wine which is distilled by a process similar to that described above. The spirit is distilled twice before being transferred to wooden barrels to mature. The maturation period depends on the quality of the brandy sought – for example a minimum of two years is required to qualify for the very superior (VS) label and four years for the very superior old pale (VSOP) label.

### 3.7.5 Beer production processes

In the whole alcohols sector, the brewing industries hold a strategic economic position with the annual world beer production exceeding 1.34 billion hL in 2002. Beer is the fifth most consumed beverage in the world after tea, carbonates, milk and coffee. It continues to be a popular drink with an average consumption of 23 litres/person/year. The brewing industry has an ancient tradition and is still a dynamic sector open to new developments in technology and scientific progress.

Till fermentation, the process units in the case of beer production are same. The final fermented grain alcohol mixture, called beer, is agitated to resuspend its solids and may be transferred to the beer well (storage vessel) for holding until it is pumped to the beer still. Distillers use mechanical or air agitation during transfer and storage to prevent settling of solids. In the instance of air agitation, trace amounts of aldehydes may be produced. The beer passes from the beer well through a pre-heater where it is warmed by the alcohol vapors leaving the still and then enters the still for distillation. The beer still vapors condensed in the pre-heater generally are returned to the beer still as reflux.

During production, brewing alternately goes through three chemical and biochemical reactions (mashing, boiling, fermentation and maturation) and three solid liquid separations (wort separation, wort clarification and rough beer clarification.)



### a) Malt

Malt is derived from a cereal grain, usually barley, after being germinated for a limited period and then dried. Malting, even if it is not carried out on a brewery site, is an integral part of the brewing industry. The barley undergoes malting process to convert it to a form suitable for brewing. During the malting process, enzymes are generated, the grain cell walls are broken down and some proteins are hydrolyzed. The malting process of barley includes cleaning, sorting, steeping, germination, drying and polishing. The barley is cleaned of dust and foreign materials and then sorted according to size with the smallest kernels (grade IV) being sold as animal feed.

### b) Milling and mashing

Malted barley is ground (either dry or wet) in a malt grinder so that the husk is left intact while the rest becomes very coarse powder, rich in starch and enzymes. The enzymes quickly degrade the starch to sugar on contact with water. The product, called sweet wort, is a mixture of partially degraded starch, sugars, enzymes, proteins and water (BPCE, 1986). The wort is separated from the spent grains by straining through a porous filter in the *lauter tun* where the grains are sprayed or sparged with water in order to extract the maximum amount of useful material. Spent grains, spent hops and trub represent a valuable source of protein for animal feed.

The spent grain yields typically 125-130 kg wet for every 100 kg of malt and its composition is 28% protein, 8% fat and 41% nitrogen-free substances (BPCE, 1986).

### c) Wort cooling and fermentation

In order to prepare for fermentation, the hopped wort is cooled to about 10°C. Further precipitation of proteins and tannin (known as cool trub or fine break) occurs during the cooling and aeration in preparation for fermentation which may continue from 2–16 days. Yeast is added in the fermentation vessel to induce fermentation of sugar wort which is converted to CO<sub>2</sub>, alcohol, heat and new yeast cells. When the fermentation process is completed, the yeast is drawn off and used for a new batch of wort with the excess being disposed of as a by-product. The surplus yeast can be resold as animal feed. On a dry solids basis, the yeast contains 50-60% proteins, 15-35% carbohydrates and 2- 12% fat making it another valuable source of protein for animal feed (BPCE, 1986).

Following the primary fermentation, the produced beer (green beer) is transferred to storage or maturation vessels for a certain period of time before filtration. Prior to filtration, the beer may be centrifuged, cooled to -1°C to -1.5°C to precipitate any suspended solids. The beer is then filtered in a Kieselguhr (diatomaceous earth) filter followed by a filter cloth.

### d) Packaging and pasteurization

Bright beer is stored and then filled into bottles or cans. In the process of filling, a small volume of beer (drip beer) is spilt. Bottling is usually preceded with bottle washing to remove any residual beer mold, cigarette butts, labels and dust particles.

### 3.7.6 Wine manufacturing process

#### a) Wine making

Once the grapes reach the winery the stems are mechanically removed and the grapes crushed to release the must, or juice. If white wine is being made the juice is run off immediately, leaving the skins and stalks behind. The juice that comes out from the pressure of the grapes alone is called free-run juice, and is generally considered superior to the juice that is pressed out. The liquid or must is then fermented in refrigerated conditions following the introduction of a yeast culture.

For red wine the process is similar except that after the grapes are crushed the skins are left in the must to colour the liquid and for the tannins in the skin to flavour it.

#### b) Utilities & auxiliary units

Alcohol production process has a high energy demand for heating and cooling purposes, in addition to high water consumption. Utility installations are therefore a key factor in this sector. Often these processes are typically supplied with heat from a steam boiler plant. Process cooling is usually provided by central ammonia-based refrigeration systems, which circulate ammonia or a secondary fluid (e.g., chilled water, brine or glycols) to the points where cooling is required. Compressed air is mainly used for instruments, actuators, pressurizing of tanks, and sometimes the transport of spent brewers grain.

#### c) Water treatment plant

Different production units typically draw water from wells or from surface intake at a lake or river, and use several different qualities of water, for example, brewing quality water for mashing, de-aerated brewing water for dilution, softened water for utility systems and tunnel pasteurizers, washdown water, etc. For this reason, breweries often have several sophisticated water treatment facilities.

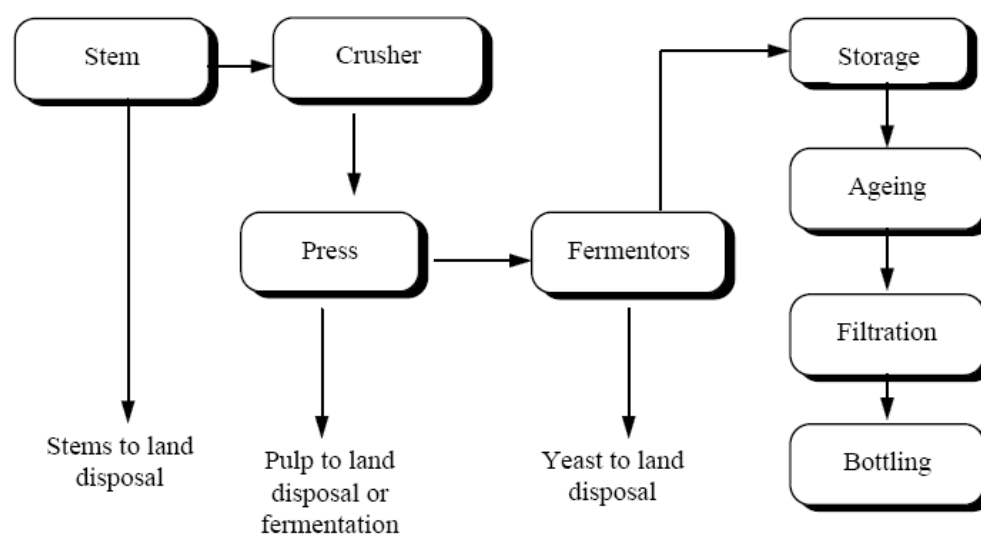

Figure 3-11: Process Flow Sheet Depicting Wine Production

#### d) CO<sub>2</sub> recovery plant

The CO<sub>2</sub> generated during the fermentation process can be collected, cleaned and stored before being used in the process. CO<sub>2</sub> is necessary for carbonation and to provide inert atmospheres as required by the process.

#### e) Nitrogen generation

Breweries may use nitrogen instead of CO<sub>2</sub> to provide inert atmospheres. Nitrogen can be generated onsite from atmospheric air through a thermal or membrane separation technique or can be supplied in bulk from external sources.

#### f) Electricity supply

Most breweries purchase electricity from the national grid, although some use cogeneration/combined heat and power (CHP) plants that produce both electricity and heat/steam.

### 3.8 In Plant Practices

#### Malting

As most of the maltries in India practice compartment malting in which manual handling of material-in-process is necessary, good housekeeping assumes importance as so far as reduction of effluent volume and pollution load is concerned. Some of the process steps where common plant practices are responsible for large effluent volume and pollution loads are enumerated here.

#### Steeping

As three steep cycles are common most maltries, they have three conical steep vessels with capacities ranging from 10-20 m<sup>3</sup> each fitted with false bottoms. Skimmings from steep vessels are normally thrown on to the floor and are washed into the drain periodically during floor washing.

#### Germination

Manual transfer of grain from the germination box to another, causes loss of some of the germinating grain. Once again these grain settle on the floor and are washed periodically into the drain. At a subsequent stage, when rootlets are removed from the malted grain, the handling causes a lot of these rootlets to settle on the floor and find their way to the drain in a similar manner. In general, the sewage in the open drains in maltries is rich in suspended solids and is the source of the odour nuisance.

#### Brewing

In general, brewing is a clean-industry in India where handling of materials is done fairly systematically and good house keeping practices are followed. However to the extent that good house keeping and in plant control of pollution are possible, the plant practices are described below.

After screening, the grain is conveyed by bucket elevators to the three-roll mill where dry milling is performed.

The grist dust generated in the mill is collected either by bag filters or by cyclones in most of the breweries. Wherever such a collection facility does not exist, the grist dust poses a pollution problem.

Mashing of the grist and separation of the spent grain is carried out in mash tun and *lauter tun* respectively. These are vertical vessels with dished ends and are made of aluminum alloy or stainless steel. *Lauter tun* is provided with raking arms and false bottom for separation of the spent grain. The brew kettle, hop jack and whirlpool used in breweries are also vertical vessels with dished ends. Generally only one number each of mash tun, *lauter tun*, brew kettle, hop jack and whirlpool is provided in the existing breweries in India and their capacities depend on the processing time. The fermenters are also cylindrical vessels with dished ends and are made of aluminum alloy or stainless steel with the provision of recovering CO<sub>2</sub> gas from the top of the vessel and yeast from the bottom of the vessel. Cooling coils are also provided around the fermenters. As the processing time in fermenters ranges from 7-10 days fermenter numbering between 10 and 18 are provided for depending on the capacity.

The processing steps in breweries are essentially batch ones and the cycle time vary from 30 minutes to four hours in most of the vessels, except in fermenters. From the capacities presented for different vessels in the processing line, it is evident that breweries have capacities of processing 200-400 hL of beer per day. Generally, one to two process cycles in each vessel per day would be enough for producing 225 hL of beer per day which is generally the maximum production in summer season in breweries. Wash water is sprayed in the processing vessels during the wash cycle. There are generally 1-2 wash cycles for each processing vessel in breweries. The wash water required is about 10% of the vessel volume.

### 3.9 Emissions from Distillery Industry

Different manufacturing process units for RS and its derivatives are depicted in Figures 3.2 and 3.3.

All processes require energy inputs which generate typical emissions (e.g., CO, CO<sub>2</sub>, NO<sub>x</sub>, SO<sub>x</sub>, PM, and VOCs) and quantity will depend on the source of fuel. Other compounds can be generated in trace quantities during fermentation including ethyl acetate, fusel oil, furfural, acetaldehyde, sulfur dioxide, and hydrogen sulfide. Acetaldehyde is a hazardous air pollutant (HAP).

#### 3.9.1 Emissions from beer & wine industries

The main pollutants generated in the brewery and winery process include wastewater discharges, air emissions and solid waste. Table 3-11 shows the potential contaminant sources in a brewing operation.

**Table 3-11: Potential Sources of Contaminants in Brewing Operation**

Stage	Environmental/Health Concern
Brew house	<ul style="list-style-type: none"> <li>▪ High discharge of organic matter</li> <li>▪ High energy consumption</li> <li>▪ High water consumption</li> <li>▪ Dust problems</li> </ul>

Stage	Environmental/Health Concern
	<ul style="list-style-type: none"> <li>▪ Caustic wastes from system cleaning</li> </ul>
Fermentation/Beer Processing	<ul style="list-style-type: none"> <li>▪ High discharge of organic matter</li> <li>▪ High water consumption</li> <li>▪ Handling of solid waste</li> <li>▪ Caustic wastes from system cleaning</li> </ul>
Packaging	<ul style="list-style-type: none"> <li>▪ High discharge of organic matter</li> <li>▪ High energy consumption</li> <li>▪ High water consumption</li> <li>▪ Handling of solid waste</li> <li>▪ High noise level</li> <li>▪ Caustic wastes from system cleaning</li> </ul>
Ancillary Operations	<ul style="list-style-type: none"> <li>▪ High energy consumption</li> <li>▪ High water consumption</li> <li>▪ Solid waste handling</li> <li>▪ High noise level</li> <li>▪ Special waste generation</li> <li>▪ Ammonia</li> </ul>

**a) Emissions to air**

Air emissions may be categorized as fugitive and point source emissions.

**Fugitive emissions**

These are emissions that are not released through a vent or stack. Examples of fugitive emissions include evaporation of wastewater, dust from stockpiles, volatilization of vapour from vats, open vessels, or spills and material handling. Emissions emanating from ridgeline roof-vents, louvers, and open doors of a building as well as equipment leaks, and leaks from valves and flanges are also examples of fugitive emissions. Emission factors are the usual method for determining losses through fugitive emissions. Possible air emissions from the beer and wine manufacturing industry are listed in Table 3-12, include activities such as pressing, ageing and packaging (bottling).

**Table 3-12 Possible Emissions from Beer and Wine Industries**

Emission Source	Possible Emissions
Fermentation	<ul style="list-style-type: none"> <li>▪ Ethanol (largest emission by volume)</li> <li>▪ Acetaldehyde</li> <li>▪ Methanol</li> <li>▪ Hydrogen Sulfide</li> <li>▪ Total Volatile Organic Compounds (Total VOCs)</li> <li>▪ Ethyl Acetate</li> </ul>
<ul style="list-style-type: none"> <li>▪ Fugitive Sources</li> <li>▪ Screening of red wine</li> <li>▪ Pressing</li> <li>▪ Ageing in Oakcooperage</li> <li>▪ Bottling process</li> <li>▪ Preservation agents</li> </ul>	<ul style="list-style-type: none"> <li>▪ Ethanol</li> <li>▪ Sulfur dioxide</li> </ul>
Fuel Combustion	<ul style="list-style-type: none"> <li>▪ Carbon monoxide (CO)</li> </ul>

Emission Source	Possible Emissions
	<ul style="list-style-type: none"> <li>▪ Sulfur dioxide (SO<sub>2</sub>)</li> <li>▪ Total VOCs</li> <li>▪ Particulate Matter (PM<sub>10</sub>)</li> <li>▪ Oxides of Nitrogen (NO<sub>x</sub>)</li> </ul>

Source: Adapted from USEPA, AP-42, Section 9.12.2.1995

### Point source emissions

These emissions are exhausted into a vent (excluding roof vent) or stack and emitted through a single point source into the atmosphere.

The main emissions to air from the manufacture of beer and wine may include VOCs, greenhouse gases, odour, noise and dust.

As per the U.S. Environmental Protection Agency (USEPA) and the California Air Resources Board, breweries and distilleries are only minor sources of emissions of VOCs to the atmosphere.

### GHG emissions

However, several greenhouse gases may also be produced in the beer, wine and spirit making process including:

- CO<sub>2</sub> (a by-product of fermentation);
- Nitrous oxide (N<sub>2</sub>O) (a by-product of the internal combustion engine); and,
- Sulphur dioxide (SO<sub>2</sub>) (if used during kilning).

In breweries, approximately 16 kg of CO<sub>2</sub> is generated in boilers burning fossil fuel for each hL of beer produced. This is much greater than the amount generated during fermentation, which is approximately 3 kg/hL of beer produced (UNEP, 1995). The GHG estimates for Australia for production of one bottle of wine is depicted in the diagram in a comprehensive LCA study on the GHG emissions in UK are given underneath.

Although odours from breweries and wineries are considered to be harmless, they represent an environmental nuisance and should be avoided wherever possible. In breweries, for example, a smell may be experienced in the vicinity of malt houses, particularly when drying the sprouted barley. In addition, odours may also be caused by emissions from the fermentation process, vapour and stack emissions from mashing and wort boiling (SEPA, 1991; UNEP, 1995).

Dust, which can result from the handling of grains during cleaning, loading and malting, is another type of emission to air that represents an environmental concern as it can result in localized or regional air quality problems (UNEP, 1995).

### b) Wastewater from brewing process

Breweries as mentioned above have a specific consumption of water ranging from 4 to 11 hL water/hL beer. In brewing, the average water consumption of around 5-6 hL/hL beer is correlated to beer production for industrial breweries. Water consumption is divided into 2/3 used in the process and 1/3 in the cleaning operations. In the same way, effluent

to beer ratio is correlated to beer production. It has been shown that the effluent load is very similar to the water load since none of this water is used to brew beer and most of it ends up as effluent.

The brewing process requires a significant amount of water and the produces wastewater is high in biological oxygen demand (BOD) and suspended solid content. Wastewater generated from beer manufacturing amounts to 65-70% of the water intake volume.

Quantity of wastewater depends on the amount of water used. A portion of the waste used is not discharged in the wastewater including: the water in the beer, evaporated water and water content in the spent grains, yeast and Kieselguhr. This amounts to about 1.5 hL/hL beer (UNEP, 1995).

The effluent contains: maltose, dextrose, wort, trub, spent grains, yeast, filter slurry (Kieselguhr and lucilite), green beer and bright beer. This effluent will have a high organic pollution load and a relatively high solid pollution load (BPCE, 1986).

Weak wort is 2-6% of the wort volume. This increases the BOD of the wastewater significantly. Rinse water, which may contain product or raw material, represents 45% of the total water use in a brewery (UNEP, 1995).

### **c) Residual beer**

Residual beer is beer lost during the various production stages which include:

- Residual amount of beer after emptying process tanks (the amount of residue depends on how efficiently the tanks are emptied)
- Pre-runs and after-runs in the Kieselguhr filter result in a mixture of beer and water, which is discharged into the sewer
- Using water to clean process pipe lines, beer is pushed out with water, and a mixture of water and beer results
- Beer rejected in the packaging area due to wrong filling height, quality defects, or incorrect placement of labels
- Returned beer
- Exploding bottles as a result of poor quality, poor bottle inspection, or lack of temperature control in the tunnel pasteurizer; and
- Use of solid additions for maturing beer resulting in loss of beer and yeast

Residual beer will equal 1-5% of total production. Most of it can be collected and reused in brewery process. Any amount not collected is discharged as effluent (UNEP, 1995).

## **3.10 In plant Pollution Control in Distilleries**

Fermenter sludge spent wash and sometimes spent lees are the contaminated streams from distilleries. Other waste streams include wash water. Cooling water and water discharged from utility service plants. Apart from considering the possibilities of recycling of the streams, which will subsequently not only reduce the total effluent but also reduce the water consumption certain by-product recovery possibilities are considered which may well be considered as a treatment method aimed at zero-discharge.

The information furnished here is based on the exhaustive literature survey, information collected during the survey and also the consultants view regarding the above.

### 3.10.1 Fermenter sludge

The volume of fermenter sludge generated from distilleries is about 0.3 kL/kL of RS produced. For distilleries having capacities of 5000 kL/annum and 10000 kL/annum of RS the volume of fermenter sludge would be about 4.5 kL/day and 9 kL/day, respectively. The fermenter sludge has solid content of about 30% by weight which comprises of mostly the spent yeast and mineral matter. The spent yeast is highly biodegradable so that the fermenter sludge stream has a biochemical oxygen demand of the order of 1,25,000 mg/L. Hence the fermenter sludge stream, although low in volume, when discharged as composite stream from fermentation house results in BOD adding to the tune of 560 kg/day and 1,120 kg/day for distilleries of 5,000 kL/annum and 10,000 kL/annum capacities respectively.

It may be possible to treat the fermenter sludge in one of three ways, either to provide a secondary yeast source or to provide cattle feed adjunct or use as fertilizer.

#### a) Processing for secondary yeast

From an examination of the composition of fermenter sludge, the solid content of the slurry and the requirement and propagation of yeast, it is clear that the solid matter of the fermenter sludge is mostly spent yeast, the aqueous part having about the same composition as that of the inflow stream to the analyzer column.

This spent yeast can be separated from the fermenter sludge stream by dewatering on a screen followed by filtration in a filter press. The filtrate will have a composition similar to that of spent wash, with a little higher percentage of alcohol and allied chemicals which in this case have not been stripped. The BOD of the filtrate will therefore be only slightly higher than that of the spent wash and can be easily treated along with the latter.

The pressed yeast can be used as secondary yeast either for growing primary yeast cultures or as bakers' yeast. Such use of this yeast had been popular abroad until the 1950's, but the practice fell more or less into obsolescence as the demand for yeast become too high to be met from such sources and quality control requirements became more stringent. However, it is felt that scope for such use may still be there in India and would be worth exploring.

#### b) Processing for cattle feed adjunct

An alternative solution, which can reduce the pollution from this stream to zero, would be to concentrate the fermenter sludge by evaporation and finally dry the concentrated matter. It has sufficient nutrient value to form excellent cattle feed. However the high mineral matter content and the nature thereof are likely to have a laxative effect on the cattle and therefore may not be fed as such. It can be used along with other feed material which would act as a diluent of the laxative effect and will none-the-less utilize the nutritional value. It is relevant to note in this context that some distilleries have malting or brewery along with a distillery and can therefore use this in conjunction with the spent grain from malting or the brewers grain from breweries or spent slops from cereal-based distilleries, the recovery of which has been suggested in the relevant sections.



### c) Source of fertilizer ingredients

Fermenter sludge, after drying, can be used as fertilizer for some crops. Use of dried fermenter sludge as fertilizer is a common practice in distilleries treating the spent wash stream in anaerobic lagoons located mostly in the western part of India. Disposal of fermenter sludge as a source of fertilizer ingredients is also practised in distilleries abroad.

As reported during a survey, the distilleries that use fermenter sludge as fertilizer dry the sludge either in open pit (sun drying) or in sludge drying beds. However, a large quantity of mineral matter present in the fermenter sludge can have some detrimental action of the crops rather than the fertility value in dried yeast and potassium salts. This matter needs to be carefully studied before using the fermenter sludge as fertilizer.

#### 3.10.2 Spent wash

As mentioned earlier, spent wash is the principal pollutant stream from distilleries discharged from the analyzer column. Spent wash stream is a continuous process effluent and its volume is about 17 kL per kL of RS. One distinct feature of spent wash is the high content of potassium salts which obviously originates from the cane sugar as it is generally very rich in potash content. The spent wash which generally contains about 8% solids can be evaporated and then subjected to incineration to recover the mineral matters present in spent wash. The ash (mineral matter) thus recovered can be further processed to potassium salt as potassium sulphate which is a potent fertilizer commonly used as one of the ingredients of mixed fertilizer the world over. Apart from this, some distilleries use evaporation of spent wash and spray drying.

The CPCB has identified different technologies for spent wash treatment and has also developed guidelines for some of these technologies, which are as follows.

- 1. Anaerobic digestion followed by two stage aeration and ferti-irrigation
- 2. Anaerobic digestion followed by controlled land application
- 3. Raw spent wash composting
- 4. Anaerobic digestion followed by Composting if filler material is adequate. If filler material is not adequate, anaerobic digestion followed by reboiler/reverse osmosis (RO)/ evaporation to reduce volume of the effluent and Composting/Drying
- 5. Raw Spent wash Concentration and Incineration in Boiler

The treatment based on the first three options discussed above is being discontinued by the MoEF as these technologies are found to have inherent limitations resulting in groundwater and soil pollution. It has also been suggested that the distilleries which are adopting these technologies shall switchover to the new technologies in a phased manner. For new or expansion of the existing distillery capacities, environmental clearances are only given based on the technologies discussed below:

#### 1) Anaerobic digestion followed by two stage aeration and ferti-irrigation

Distilleries attached with Sugar units can adopt anaerobic digestion of spent wash followed by composting if sufficient filler material is available for composting. In case the filler material is not adequate, the effluent quantity shall be reduced by Reboiler/ evaporation/RO to match the quantity of press mud. The concentrated effluent can be dried in spray dryers as powder which can be sold as a fertilizer. The anaerobic digestion followed by evaporation in Multiple Effect Evaporators (MEE) to reduce the volume of

the effluent and composting is adopted by some distilleries in Maharashtra and Karnataka.

The anaerobic digestion followed by evaporation in MEE and spray drying is followed at The Ugar Sugar Works Ltd., located in Belgaum, Karnataka.

The industry shall have to develop suitable system for reduction of effluent as there are no specific guidelines developed for evaporators/reverse osmosis/reboiler/spray dryers.

## 2) Anaerobic digestion followed by controlled land application

For standalone distilleries, the only option is to concentrate spent wash and burn in boiler. The distilleries which are attached to sugar industries may also adopt this technology.

The concentration and incineration technology has been also adopted by some distilleries in UP, Maharashtra and Karnataka.

There are no guidelines developed for boilers. However, the following issues may be considered while adopting this technology.

- (A) Sludge from fermenters/settled sludge from storage tanks which may be around 3-5 % of spent wash quantity shall have to be treated/disposed.
- (B) The condensates from the evaporators while concentrating spent wash would have COD concentration between 10,000-15,000 mg/L, which needs to be treated. The pH of condensate is around 4.0 – 4.6 which requires neutralisation. The quantity of condensate generated may be around 50- 55% of the effluent quantity generated.

The suggested treatment for condensates may be biological such as anaerobic followed by aerobic treatment and recycling it as make up water after treatment on RO principles. The sludge from biological treatment/reject from RO shall have to be treated either by composting or land fill or any other suitable method.

### 3.11 Classification of Distilleries for Wastewater Treatment Methods

There are very few distilleries which use malt exclusively or even as a substantial part of their feed material. For the model case, therefore the consideration is limited to distilleries producing RS from molasses, which may or may not be converting part thereof to IMFL.

The capacity of distilleries based on molasses varies from 2,000 to as high as 60,000 kL of RS per annum. Capacity-wise the distilleries can be classified into three broad groups as follows:

**Table 3-13: Classification of Distilleries based on Capacity**

Production Scale	Production Capacity kL/Annum
Small	Up to 5,000
Medium	Above 5,000 and Up to 10,000
Large	Above 10,000 and Up to 20,000

Most of the distilleries in the country fall under small and medium groups. Among large scale distilleries a number have a capacity in the range of 10,000 - 15,000 kL/annum, and there are even two distilleries having capacity of the order of 15,000 - 20,000 kL/annum.

The main effluent discharge from the distilleries is spent wash, a continuous process stream, and its volume is practically proportional to the RS production, since the alcohol content achieved in the fermenter is more or less standard. The fermenter sludge, spent lees and wash water are also more or less proportional to alcohol production.

Based on the production capacities of existing distilleries and the above discussions, two model cases *i.e.*, 5,000 kL of RS/annum and 10,000 kL of RS/annum are selected for designing the treatment schemes and estimating the cost thereof. The total effluent volume treated in the proposed treatment schemes for the two model cases are presented here along with the principal characteristics.

**Table 3-14: Total Effluent Volume Proposed for Treatment**

Capacity of Production in kL/annum	Spent wash + Fermenter Wash Water Flow in m <sup>3</sup> /day	Total Volume of Effluent Treated in m <sup>3</sup> /day	BOD5 in mg/l	Suspended Solids in mg/l
5,000	200	200	60,000	14,000
10,000	400	400	60,000	14,000

### 3.11.1 Treatment schemes

As per the MoEF Guidelines, following options can be adopted for the treatment of effluent from distillery units.

- Anaerobic digestion followed by evaporation and composting (if the distillery unit is attached to sugar unit)
- Concentration and burning in a boiler for standard distilleries.

### 3.12 Summary of Applicable National Regulations

There are well-defined regulatory requirements, which imply that the government must regulate various aspects of the operations and construction of distillery units to reduce their environmental and social impacts.

#### 3.12.1 General description of major statutes

A comprehensive list of legal instruments applicable to distilleries is annexed as **Annexure II**.

#### 3.12.2 General standards for discharge of environmental pollutants

List of general standards for discharge of environmental pollutants as per CPCB is given in **Annexure III**.

### 3.12.2.1 Industry specific standards

The standard for SPM concentration is 150 mg/Nm<sup>3</sup> irrespective of the type of boiler. Standards for wastewater discharges from distilleries are given in Table 3-15.

**Table 3-15: Standards for Wastewater Discharges from Distilleries**

S.No.	Parameter	Industrial Sector
		Fermentation (Distilleries, Matrices & Breweries)
1	PH	5.5 - 9.0
2	Temperature	-
3	Suspended Solids, mg/l	100
4	BOD, mg/l(27°C for 3 days)	30 (disposal into inland water) 100 (disposal on land)
5	COD, mg/l	-
6	Oil & Grease, mg/l	-
7	Phenol , mg/l	-
8	Sulphides, mg/l	-
9	Sulphate, mg/l	-
10	Chloride, mg/l	-
11	Ammonical Nitrogen, mg/l	-
12	Total Residual chlorine, mg/l	-
13	Colour, hazen unit	All efforts should be made to remove colour, odour as far as practicable.
14	Bio-assay test (with 1:8 dilution of effluents)	
15	Cyanides, mg/l	-
16	Mercury, mg/l	-
17	Copper, mg/l	-
18	Iron, mg/l	-
19	Zinc, mg/l	-
20	Chromium (total) , mg/l	-
21	Chromium (hexavalent), mg/l	-
22	Nickel, mg/l	-
23	Cadmium, mg/l	-

S.No.	Parameter	Industrial Sector
		Fermentation (Distilleries, Matrices & Breweries)
24	Lead, mg/l	-
25	Manganese as Mn , mg/l	-
26.	Total metal, , mg/l	

## 4. OPERATIONAL ASPECTS OF EIA

Prior environmental clearance process has been revised in the Notification issued on 14<sup>th</sup> September, 2006 into following four major stages *i.e.*, screening, scoping, public consultation and appraisal. Each stage has certain procedures to be followed. This section deals with all the procedural and technical guidance, for conducting objective-oriented EIA report, its review and decision-making. Besides, the Notification also classifies projects into Category A, which require prior environmental clearance from MoEF and Category B from SEIAA/UTEIAA.

### Consistency with other requirements

- Clearance from other regulatory bodies is not a prerequisite for obtaining the prior environmental clearance and all such clearances will be treated as parallel statutory requirements.
- Consent for Establishment (CFE) and Prior environmental clearance are two different legal requirements a project proponent should acquire. Therefore, these two activities can be initiated and proceeded with simultaneously.
- If a project falls within the purview of CRZ and EIA Notifications, then the project proponent is required to take separate clearances from the concerned Authorities.
- Rehabilitation and Resettlement (R&R) issues need not be dealt under the EIA Notification as other statutory bodies deal with these issues. However, socio-economic studies may be considered while taking environmental decisions.

### 4.1 Coverage of Distillery Industry Under the Purview of Notification

All the new distillery industrial projects including expansion and modernization require prior environmental clearance. Based on pollution potential, these projects are classified into Category A and Category B *i.e.*

- Category A:
  - All molasses based distilleries; and/or
  - All cane juice/non-molasses based distilleries with  $\geq 30$  KLD
- Category B: All cane juice/non-molasses based distilleries with  $< 30$  KLD

Besides there is a general condition, when it applies, a Category B project will be treated as Category A project. These conditions are discussed in subsequent sections.

The sequence of steps in the process of prior environmental clearance for Category A projects and the Category B projects are shown in Figure 4.1 and Figure 4.2 respectively. The timelines indicated against each stage are the maximum permissible time lines set in the Notification for said task. In case the said task is not cleared/objected by the concerned Authority, within the specified time, said task is deemed to be cleared, in accordance to the proposal submitted by the proponent. Each stage in the process of prior environmental clearance for the distillery industry is discussed in subsequent sections.

In case of Expansion or Modernization of the developmental Activity:

- Any developmental activity, which has an EIA clearance (existing plants), when undergoes expansion or modernization (change in process or technology) with increase in production capacity or any change in product mix beyond the list of products cleared in the issued clearance, is required to submit new application for EIA clearance.
- Any developmental activity, which is listed in Schedule of the EIA Notification and due to expansion of its total capacity, if falls under the purview of either Category B or Category A, then such developmental activity requires clearance from respective authorities.

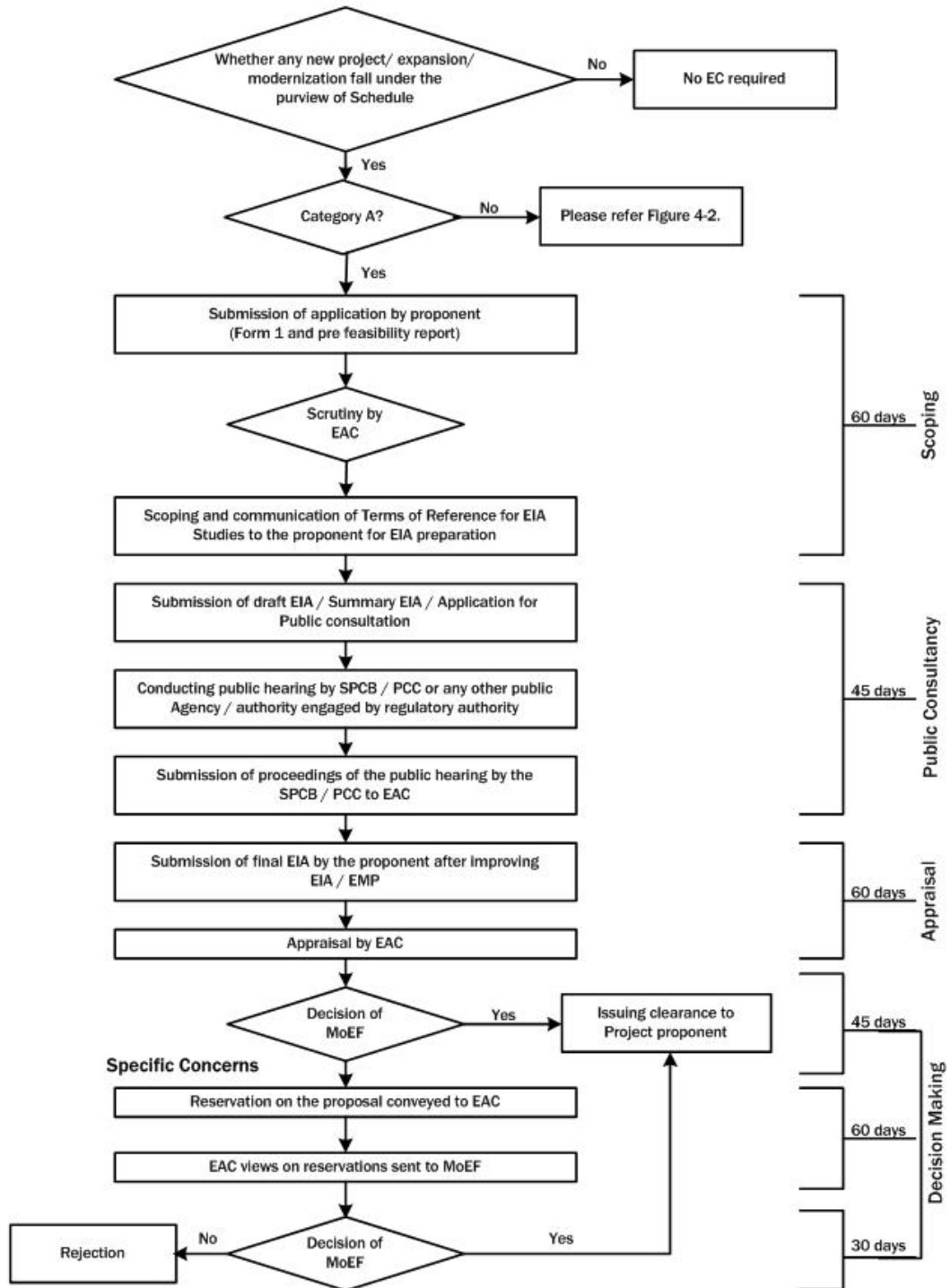

Figure 4-1: Prior Environmental Clearance Process for Activities Falling Under Category A



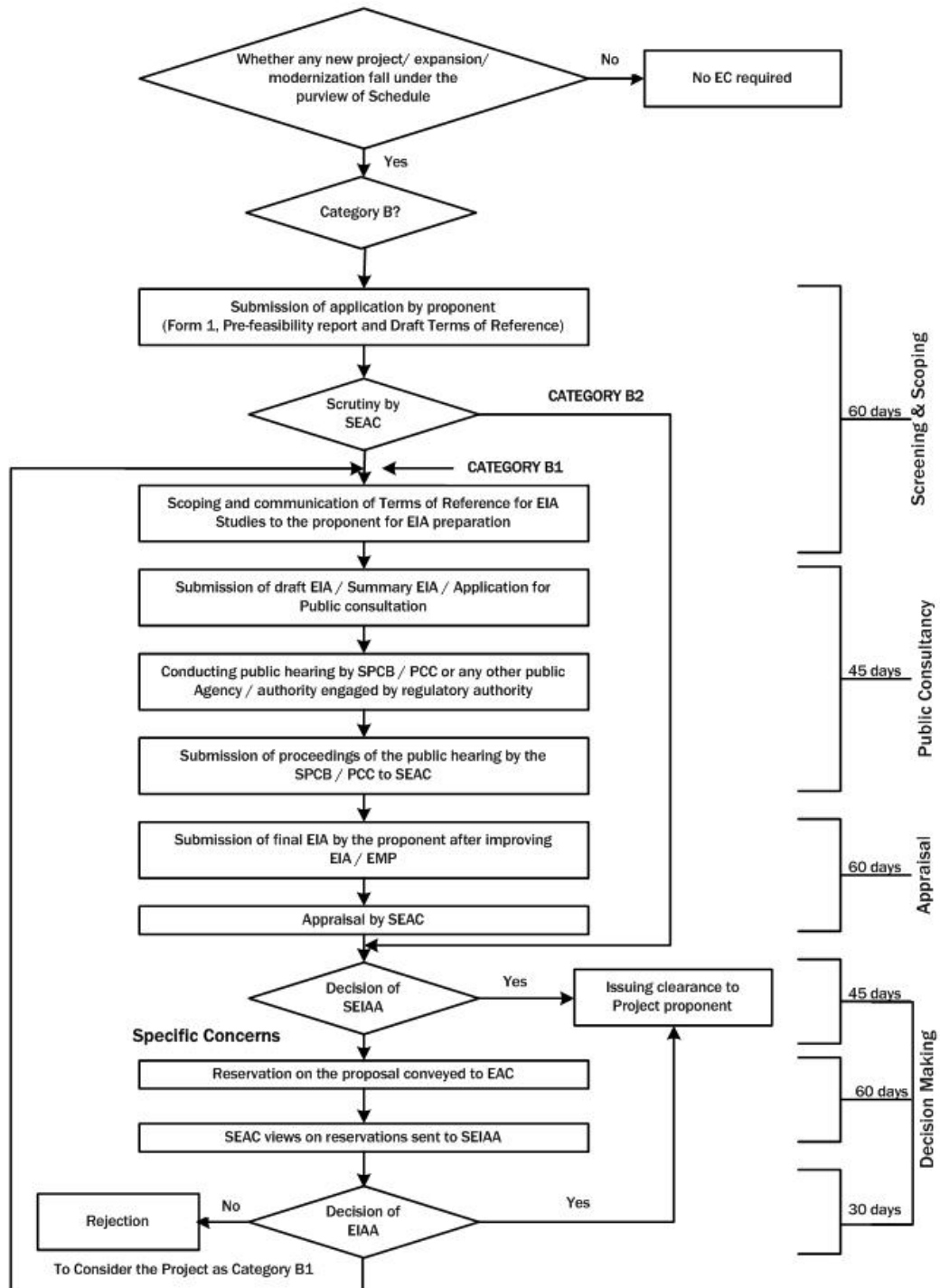

Figure 4-2: Prior Environmental Clearance Process for Activities Falling Under Category B

## 4.2 Screening

Screening of the project shall be performed at the initial stage of the project development so that proponents are aware of their obligations before deciding on the budget, project design and execution plan.

This stage is applicable only for Category 'B' developmental activity *i.e.*, if general conditions are applicable for a Category B project, then it will be treated as Category A project. Besides, screening also refers to the classification of Category B projects into either Category B1 or Category B2. Category B1 projects require to follow all stages applicable for Category A projects, but are processed at the SEIAA/UTEIAA. Category B2 projects, on the other hand, do not require either EIA or public consultation.

As per the Notification, classification of Category B projects falls under the purview of the SEAC. This manual provides certain guidelines to the stakeholders for classification of Category B1 and Category B2.

### 4.2.1 Applicable conditions for Category B projects

#### General condition:

- All cane juice/non-molasses based distilleries with <30 KLD (usually falling under Category B) will be treated as Category A, if located in whole, or in part within 10 km from the boundary of:
  - Protected Areas notified under the Wild Life (Protection) Act, 1972
  - Critically Polluted areas as notified by the CPCB from time to time.
  - Eco-sensitive areas as notified under Section 3 of the E(P) Act, 1986, such as Mahabaleshwar, Panchgani, Matheran, Panchmarhi, Dahanu, Doon valley and
  - Inter-State boundaries and international boundaries – provided the requirement regarding distance of 10 km of the inter-state boundaries can be reduced or completely done away with by an agreement between the respective States/UTs sharing the common boundary in case the activity does not fall within 10 km of the areas mentioned above
- If any of the conditions listed in above general condition applies, then a Category B project will be treated as Category A
- The SEIAA shall base its decision on the recommendations of a State/UT level EAC for the purpose of environmental clearance
- In absence of a duly constituted SEIAA or SEAC, a Category B project shall be appraised at the Central level *i.e.*, at the MoEF
- The EAC at the State/UT level shall screen the projects or activities in Category B. SEAC shall meet at least once every month.
- If any Category B distillery project/activity, after proposed expansion of capacity/production or fuel change, falls under the purview of Category A in terms of production capacity, then clearance is required from the Central Government.

### 4.2.2 Criteria for classification of Category B1 and B2 projects

The classification of Category B projects or activities into B1 or B2 (except the project or activities listed in item 8(b) in the schedule to the EIA Notification, 2006) will be determined based on whether or not the project or activity requires further environmental

studies for preparation of an EIA for its appraisal prior to the grant of environmental clearance. The necessity of which will be decided, depending upon the nature and location specificity of the project, by SEAC after scrutiny of the applications seeking environmental clearance for Category B projects or activities.

The projects requiring an EIA report shall be included in Category B1 and remaining projects will fall under Category B2 and will not require an EIA report and public consultation.

### 4.2.3 Application for prior environmental clearance

- The project proponent, after identifying the site and carrying out a pre-feasibility study, is required to apply for the prior environmental clearance in Form 1 given in **Annexure IV**. The proponent has to submit the filled in Form 1 along with pre-feasibility report and draft ToR for EIA studies to the concerned Authority *i.e.*, MoEF, Government of India for Category A projects and SEIAA in case of Category B projects. Please refer subsequent sections for the information on how to fill Form 1, contents of pre-feasibility report and draft ToR for distilleries.
- Prior environmental clearance is required before starting any construction work, or preparation of land on the identified site/project or activity by the project management, except for securing the land.
- If the application is made for a specific developmental activity, which has an inherent area development component as a part of its project proposal and the same project also attract the construction and area development provisions under 8a and 8b of the Schedule, then the project will be seen as a developmental activity other than 8a and 8b of the Schedule.

### 4.2.4 Siting guidelines

These are the guidelines, stakeholders may consider while siting the developmental projects, to minimize the associated possible environmental impacts. In some situations, adhering to these guidelines is difficult and unwarranted. Therefore, these guidelines may be kept in the background, as far as possible, while taking the decisions.

#### Areas preferably be avoided

While siting industries, care should be taken to minimize the adverse impacts of the industries on immediate neighborhood as well as distant places. Some of the natural life sustaining systems and some specific landuses are sensitive to industrial impacts because of the nature and extent of fragility. In order to protect such sites, the industries may maintain the following distances, as far as possible from the specific areas listed:

- Ecologically and/or otherwise sensitive areas: Preferably 5 km; depending on the geo-climatic conditions the requisite distance may be decided appropriately by the agency.
- Coastal Areas: Preferably ½ km. away from high tide line (HTL).
- Flood Plain of the riverine system: Preferably ½ km away from flood plain or modified flood plain affected by dam in the upstream or by flood control systems.
- Transport/Communication System: Preferably ½ km. away from highway and railway line.

- Major settlements (3, 00,000 population): Distance from major settlements is difficult to maintain because of urban sprawl. At the time of siting of the industry, if the notified limit of any major settlement is found to be within 50 km., from the project boundary, the spatial direction of growth of the settlement for at least a decade must be assessed. Subsequently, the industry shall be sited at least 25 km from the projected growth boundary of the settlement.
- Critically polluted areas are identified by MoEF from time-to-time. Current list of critically polluted areas is given in **Annexure V**.

Note:

*Ecological and/or otherwise sensitive areas include (i) Religious and Historic Places; (ii) Archaeological Monuments (e.g. identified zone around Taj Mahal); (iii) Scenic Areas; (iv) Hill Resorts; (v) Beach Resorts; (vi) Health Resorts; (vii) Coastal Areas rich in Corals, Mangroves, Breeding Grounds of Specific Species; (viii) Estuaries rich in Mangroves, Breeding grounds of Specific Species; (ix) Gulf Areas; (x) Biosphere Reserves; (xi) National Parks and Sanctuaries; (xii) Natural lakes, Swamps; (xiii) Seismic Zones; (xiv) Tribal Settlements; (xv) Areas of Scientific and Geological Interest; (xvi) Defence Installations, specially those of security importance and sensitive to pollution; (xvii) Border Areas (International) and (xviii) Air Ports.*

*Pre-requisite: State and Central Governments are required to identify such areas on a priority basis.*

### **General siting factors**

In any particular selected site, the following factors must also be recognized.

- No forest land shall be converted into non-forest activity for the sustenance of the industry (Ref: Forest Conversation Act, 1980).
- No prime agricultural land shall be converted into industrial site.
- Within the acquired site the industry must locate itself at the lowest location to remain obscured from general sight.
- Land acquired shall be sufficiently large to provide space for appropriate green cover including green belt around the battery limit of the industry.
- Enough space should be provided for storage of recyclable solid wastes so that these could be available for possible reuse.
- Layout of the industry that may come up in the area must conform to the landscape of the area without affecting the scenic features of that place.
- Associated township of the industry may be created at a space having physiographic barrier between the industry and the township.

### **4.3 Scoping for EIA Studies**

Scoping exercise is taken up soon after the project contours are defined. The primary purpose of scoping is to identify concerns and issues which are important to project decisions. Besides, scoping defines the requirements and boundaries of an EIA study.

Scoping refers to the process by which the EAC in the case of Category ‘A’ projects or activities, and SEAC in case of Category ‘B1’ projects, including applications for expansion and/or modernization of existing projects, determines ToR for EIA studies

addressing all relevant environmental concerns for the preparation of an EIA Report for a particular project.

- Project proponent shall submit the application to the concerned Authority. The application (Form 1 as given in **Annexure IV**) shall be attached with pre-feasibility report and proposed ToR for EIA Studies. The proposed sequence to arrive at the draft ToR is discussed below:
  - Pre-feasibility report provides a summary of project details and also the likely environmental concerns based on secondary information, which will be availed for filling Form 1.
  - From pre-feasibility report and Form 1, valued environmental components (VECs) may be identified for a given project (receiving environment/social components, which are likely to get effected due to the project operations/activities).
  - Once the project details from the pre-feasibility report & Form 1; and VECs are identified, a matrix establishing the interactions which can lead to the effects/impacts could be developed (Qualitative analysis).
  - For each identified possible effect in the matrix, significance analysis could be conducted to identify the impacts, which need to be studied further (quantitative analysis) in subsequent EIA studies. All such points find a mention in the draft ToR to be proposed by the project proponent. The draft ToR shall include applicable baseline parameters (refer annexure VIII) and impact prediction tools (refer annexure X) proposed to be applied.
  - The information to be provided in pre-feasibility report, guidelines for filling Form 1 and guidelines for developing draft ToR is summarized in subsequent sections.
  - Authority consults the respective EAC/SEAC to reply to the proponent. The EAC/SEAC concerned reviews the application form, pre-feasibility report and proposed draft ToR by the proponent and make necessary additions/deletions to make it a comprehensive ToR that suits the statutory requirements for conducting the EIA studies.
- The concerned EAC/SEAC may constitute a sub- committee for a site visit, if considered necessary. The sub-committee will act up on receiving a written approval from the chairperson of EAC/SEAC concerned. Project proponent will facilitate such site visits of the sub-committees.
- EAC/SEAC shall provide an opportunity to the project proponent for presentation and discussions on the proposed project and related issues as well as the proposed ToR for EIA studies. If the State Government desires to present their views on any specific project in the scoping stage, it can depute an officer for the same at the scoping stage to EAC, as an invitee but not as a member of EAC. However, non-appearance of the project proponent before EAC/SEAC at any stage will not be a ground for rejection of the application for the prior environmental clearance.
- If a new or expansion project is proposed in a problem area as identified by the CPCB, then the Ministry may invite a representative of SEIAA to the EAC to present their views, if any at the stage of scoping.

- The final set of ToR for EIA studies shall be conveyed to the proponent by the EAC/SEAC within sixty days of the receipt of Form 1 and Pre-feasibility report. If the finalized ToR for EIA studies is not conveyed to the proponent within sixty days of the receipt of Form 1, the ToR suggested by the proponent shall be deemed as final and will be approved for EIA studies.
- Final ToR for EIA studies shall be displayed on the websites of the MoEF/SEIAA.
- Applications for prior environmental clearance may be rejected by the concerned Authority based on the recommendation of the EAC or SEAC concerned at this stage itself. In case of such rejection, the decision together with reasons for the same, shall be communicated to the proponent in writing within sixty days of the receipt of the application.
- The final EIA report and other relevant documents submitted by the applicant shall be scrutinized by the concerned Authority strictly with reference to the approved ToR for EIA studies.

#### 4.3.1 Pre-feasibility report

The pre-feasibility report should include, but not limited to highlight the proposed project information, keeping in view the environmental sensitivities of the selected site, raw material, technology options and its availability. Information required in pre-feasibility report varies from case to case even in same sector depending upon the local environmental setting within which the plant is located/proposed. However, the environmental information which may be furnished in the pre-feasibility report may include as under:

- Description of the project, including in particular:
  - a description of the physical characteristics of the whole project and the land-use requirements during the construction and operational phases
  - a description of the main characteristics of the production processes, for instance, nature and quantity of materials used
  - an estimate, by type and quantity, of expected residues and emissions (water, air and soil pollution, noise, vibration, light, heat, radiation, *etc.*) resulting from the operation of the proposed project
- An outline of the main alternatives studied by the developer and an indication of the main reasons for this choice, taking into account the environmental effects.
- A description of the aspects of the environment likely to be significantly affected by the proposed project, including, in particular, population, fauna, flora, soil, water, air, climatic factors, material assets, including the architectural and archaeological heritage, landscape and the inter-relationship between the above factors.
- A description of the likely significant effects of the proposed project on the environment resulting from:
  - existence of project
  - use of natural resources – Specific consumptions
  - emission of pollutants, the creation of nuisances and the elimination of waste,
  - project proponent's description of the forecasting methods used to assess the effects on the environment

- A description of the measures envisaged to prevent, reduce and where possible offset any significant adverse effects on the environment
- A non-technical summary of the information provided under the above headings
- An indication of any difficulties (technical deficiencies or lack of know-how) encountered by the developer in compiling the required information

Details of the above listed points which may be covered in pre-feasibility report are listed in **Annexure VI**.

### 4.3.2 Guidance for Filling Information in Form 1

The information given in specifically designed pre-feasibility report for this developmental activity may also be availed for filling Form 1.

Form 1 is designed to help users identify the likely significant environmental effects of proposed projects right at the scoping stage. There are two stages for providing information under two columns:

- First - identifying the relevant project activities from the list given in column 2 of Form 1. Start with the checklist of questions set out below and complete Column 3 by answering:
  - Yes - if the activity is likely to occur during implementation of the project
  - No - if it is not expected to occur
  - May be - if it is uncertain at this stage whether it will occur or not
- Second – For each activity for which the answer in Column 3 is “Yes” the next step is to refer to the fourth column which quantifies the volume of activity which could be judged as significant impact on the local environmental characteristics, and identify the areas that could be affected by that activity during construction /operation / decommissioning of the project. Form 1 requires information within 15 km around the project, whereas actual study area for EIA will be as prescribed by respective EAC/SEAC. Project proponent will need information about the surrounding VECs in order to complete this Form 1.

### 4.3.3 Identification of appropriate valued environmental components

VECs are components of natural resources and human world that are considered valuable and are likely to be affected by the project activities. Value may be attributed for economic, social, environmental, aesthetic or ethical reasons. VECs represent the investigative focal point for further EIA process. The indirect and/or cumulative effects can be concerned with indirect, additive or even synergistic effects due to other projects or activities or even induced developments on the same environmental components as would be considered direct effects. But such impacts tend to involve larger scale VECs such as within entire region, river basins or watersheds; and, broad social and economic VECs such as quality of life and the provincial economy. Once the VECs are identified, appropriate indicators may be selected for impact assessments on the respective VECs.

### 4.3.4 Methods for identification of impacts

There are various factors which influence the approach adopted for the assessment of direct, indirect, cumulative impacts, *etc.* for a particular project. The method should be practical and suitable for the project given the data, time and financial resources available.

However, the method adopted should be able to provide a meaningful conclusion from which it would be possible to develop, where necessary, mitigation measures and monitoring. Key points to consider when choosing the method(s) include:

- Nature of the impact(s)
- Availability and quality of data
- Availability of resources (time, finance and staff)

The method chosen should not be complex, but should aim at presenting the results in a way that can be easily understood by the developer, decision maker and the public. A comparative analysis of major impact identification methods is given in the following Table 4-1.

**Table 4-1: Advantages and Disadvantages of Impact Identification Methods**

	Description	Advantages	Disadvantages
Checklists	<ul style="list-style-type: none"> <li>▪ Annotate the environmental features that need to be addressed when identifying the impacts of activities in the project</li> </ul>	<ul style="list-style-type: none"> <li>▪ Simple to understand and use</li> <li>▪ Good for site selection and priority setting</li> <li>▪ Simple ranking and weighting</li> </ul>	<ul style="list-style-type: none"> <li>▪ Do not distinguish between direct and indirect impacts</li> <li>▪ Do not link action and impact</li> <li>▪ The process of incorporating values can be controversial</li> </ul>
Matrices	<ul style="list-style-type: none"> <li>▪ Identify the interaction between project activities (along one axis) and environmental characteristics (along other axis) using a grid like table</li> <li>▪ Entries are made in the cells which highlights impact severity in the form of symbols or numbers or descriptive comments</li> </ul>	<ul style="list-style-type: none"> <li>▪ Link action to impact</li> <li>▪ Good method for displaying EIA results</li> </ul>	<ul style="list-style-type: none"> <li>▪ Difficult to distinguish direct and indirect impacts</li> <li>▪ Significant potential for double-counting of impacts</li> </ul>
Networks	<ul style="list-style-type: none"> <li>▪ Illustrate cause effect relationship of project activities and environmental characteristics</li> <li>▪ Useful in identifying secondary impacts</li> <li>▪ Useful for establishing impact hypothesis and other structured science based approaches to EIA</li> </ul>	<ul style="list-style-type: none"> <li>▪ Link action to impact</li> <li>▪ Useful in simplified form for checking for second order impacts</li> <li>▪ Handles direct and indirect impacts</li> </ul>	<ul style="list-style-type: none"> <li>▪ Can become very complex if used beyond simplified version</li> </ul>
Overlays	<ul style="list-style-type: none"> <li>▪ Map the impacts spatially and display them pictorially</li> <li>▪ Useful for comparing site and planning alternatives for routing linear developments</li> <li>▪ Can address cumulative effects</li> <li>▪ Information incentive</li> </ul>	<ul style="list-style-type: none"> <li>▪ Easy to understand</li> <li>▪ Good to display method</li> <li>▪ Good siting tool</li> </ul>	<ul style="list-style-type: none"> <li>▪ Address only direct impacts</li> <li>▪ Do not address impact duration or probability</li> </ul>
GIS	<ul style="list-style-type: none"> <li>▪ Maps the impacts spatially</li> </ul>	<ul style="list-style-type: none"> <li>▪ Easy to</li> </ul>	<ul style="list-style-type: none"> <li>▪ Do not address</li> </ul>



### Operational Aspects of an EIA

	Description	Advantages	Disadvantages
(Geographical Information Systems)	<ul style="list-style-type: none"> <li>and display them pictorially</li> <li>▪ Useful for comparing site and planning alternatives for routing linear developments</li> <li>▪ Can address cumulative effects</li> <li>▪ Information incentive</li> </ul>	<ul style="list-style-type: none"> <li>understand</li> <li>▪ Good to display method</li> <li>▪ Good siting tool</li> <li>▪ Excellent for impact identification and analysis</li> </ul>	<ul style="list-style-type: none"> <li>impact duration or probability</li> <li>▪ Heavy reliance on knowledge and data</li> <li>▪ Often complex and expensive</li> </ul>
Expert System	<ul style="list-style-type: none"> <li>▪ Assist diagnosis, problem solving and decision making</li> <li>▪ Needs inputs from user by answering systematically developed questions to identify impacts and determine their mitigability and significance</li> <li>▪ Information intensive, high investment methods of analysis</li> </ul>	<ul style="list-style-type: none"> <li>▪ Excellent for impact identification and analysis</li> <li>▪ Good for experimenting</li> </ul>	<ul style="list-style-type: none"> <li>▪ Heavy reliance on knowledge and data</li> <li>▪ Often complex and expensive</li> </ul>

The project team made an attempt to construct an impact matrix considering major project activities (generic operations) and stage-specific likely impacts which is given in Table 4-2.

While the impact matrix is each project-specific, Table 4-2 may facilitate the stakeholders in identifying a set of components and phase-specific project activities for determination of likely impacts. However, the location-specific concerns may vary from case to case, therefore, the components even without likely impacts are also retained in the matrix for the location-specific reference.

Table 4-2: Matrix of Impacts

1	2	3	PRE-CONSTRUCTION				CONSTRUCTION/ ESTABLISHMENT					OPERATION AND MAINTENANCE						
			4	5	6	7	8	9	10	11	12	13	14	15	16	17	18	
ENVIRONMENT	COMPONENT	Project Activity Parameter/ Factor	Detailed Topographic Survey	Land Acquirement	Site Clearing	Burning of wastes, refuse and cleared vegetation	Site Preparation / Change in Topography	Civil works such as earth moving and building of structures including temporary structures	Heavy Equipment operations	Disposal of construction wastes	Influx of construction workers	Transportation of material	Movement of Energy Reserves	Operation of power source and generator facilities	Operation of cooling systems	Storage of raw materials and Finished products	Waste management	
PHYSICAL	Soil	Erosion Risks																
		Contamination						*										*
		Soil Quality			*				*	*								
	Resources	Fuels/ Electricity											*	*				
		Construction material- stone, aggregates Land especially undeveloped or agricultural land			*				*									
	Water	Interpretation or Alteration of River Beds					*											
		Alteration of Hydraulic Regime																
		Alteration of surface run-off and interflow					*	*										
		Alteration of aquifers					*	*										
		Contamination						*										*
	Air	Temperature																
		Air quality				*		*	*			*	*	*				
		Noise			*			*	*			*	*	*	*			
		Climate																
	BIOLOGICAL	Terrestrial fauna	Effect on grass & flowers			*												
			Effect on trees & shrubs			*												
Effect on farmland					*													
Endangered species					*													

			PRE-CONSTRUCTION				CONSTRUCTION/ ESTABLISHMENT					OPERATION AND MAINTENANCE								
1	2	3	4	5	6	7	8	9	10	11	12	13	14	15	16	17	18			
<b>SOCIAL</b>	<b>Aquatic biota</b>	Habitat removal																		
		Contamination of habitats																		
		Reduction of aquatic biota														*				
	<b>Economy</b>	Creation of new economic activities	*	*										*						
		Commercial value of properties		*																
		Conflict due to negotiation and/ compensation payments		*																
		Generation of temporary and permanent jobs									*	*	*	*						
		Effect on crops			*				*											
		Reduction of farmland productivity			*															
		Income for the state and private sector		*																
		Electricity tariffs													*					
		Savings in foreign currency for the state																		
		<b>Education</b>	Training in new technologies	*														*		*
	Training in new skills to workers		*																	
	<b>Public order</b>	Political Conflicts		*								*								
		Unrest, Demonstrations & Social conflicts		*								*	*				*		*	
	<b>Infrastructure and services</b>	Conflicts with projects of urban, commercial or Industrial development	*	*					*	*		*	*							
		Accidents caused by																*		
		Temporary Chronic												*			*			
		Chronic																		
<b>Cultural</b>		Land use		*	*	*														

			PRE-CONSTRUCTION				CONSTRUCTION/ ESTABLISHMENT					OPERATION AND MAINTENANCE					
1	2	3	4	5	6	7	8	9	10	11	12	13	14	15	16	17	18
		Recreation			*												
		Aesthetics and human interest			*	*				*							*
		Cultural status									*						

Note:

1. The above table represents a model for likely impacts, which will have to be arrived case-to-case basis considering VECs and significance analysis (Ref Section 2.9).

2. Project activities are shown as indicative. However, in Form 1 (application for EIA Clearance), for any question for which answer is 'Yes', then the corresponding activity shall reflect in project activities. Similarly 'parameters'/'factors' will also be changed within a component in order to reflect the target species of prime concern in the receiving local environment.

### 4.3.5 Testing the Significance of impacts

The following set of conditions may be used as the checklist for testing the significance of the impacts and also to provide information in Column IV of Form 1.

- Will there be a large change in environmental conditions?
- Will new features be out-of-scale with the existing environment?
- Will the effect be unusual in the area or particularly complex?
- Will the effect extend over a large area?
- Will there be any potential for trans-frontier impact?
- Will many people be affected?
- Will many receptors of other types (fauna and flora, businesses, facilities) be affected?
- Will valuable or scarce features or resources be affected?
- Is there a risk that environmental standards will be breached?
- Is there a risk that protected sites, areas, features will be affected?
- Is there a high probability of the effect occurring?
- Will the effect continue for a long time?
- Will the effect be permanent rather than temporary?
- Will the impact be continuous rather than intermittent?
- If it is intermittent will it be frequent rather than rare?
- Will the impact be irreversible?
- Will it be difficult to avoid, or reduce or repair or compensate for the effect?

For each “Yes” answer in column 3, the nature of effects and reasons for it should be recorded in column 4. The questions are designed so that a “Yes” answer in column 3, will generally point towards the need for analyzing for the significance and requirement for conducting impact assessment for the effect.

### 4.3.6 Terms of reference for EIA studies

ToR for EIA studies in respect of Distilleries may include, but not limited to the following:

- 1) Executive summary of the project – giving a *prima facie* idea of the objectives of the proposal, use of resources, justification, *etc.* In addition, it should provide a compilation of EIA report including EMP and post-project monitoring plan in brief.

#### Project description

- 2) Justification for selecting the proposed unit size.
- 3) Land requirement for the project including its break up for various purpose, its availability and optimization.
- 4) Details of proposed layout clearly demarcating various units within the plant.
- 5) Complete process flow diagram describing each unit, its processes and operations, along with material and energy inputs and outputs (material and energy balance).
- 6) Number of working days in the distillery unit.
- 7) Details of proposed source-specific pollution control schemes and equipments to meet the national standards.
- 8) Details on requirement of raw materials, its source and storage at the plant.

- 9) Details on requirement of energy and water along with its source and authorization from the concerned department.
- 10) Details on water balance including quantity of effluent generated, recycled & reused. Efforts to minimize effluent discharge and to maintain quality of receiving water body.
- 11) Details of effluent treatment plant, inlet and treated water quality with specific efficiency of each treatment unit in reduction in respect of all concerned/regulated environmental parameters.
- 12) Details of the proposed methods of water conservation and recharging.
- 13) Detailed plan of spent wash utilization / management.
- 14) Detailed plan of molasses storage as per the CPCB latest guidelines.
- 15) Management plan for solid/hazardous waste generation, storage, utilization and disposal including boiler ash utilization and disposal.
- 16) Details regarding infrastructure facilities such as sanitation, fuel storage, restroom, *etc.* to the workers during construction and operation phase.
- 17) In case of expansion of existing industries, remediation measures adopted to restore the environmental quality if the groundwater, soil, crop, air, *etc.* are affected and a detailed compliance to the environmental clearance/consent conditions.
- 18) Any litigation pending against the project and /or any direction /order passed by any Court of Law related to the environmental pollution and impacts in the last two years, if so, details thereof.

### **Description of the environment**

- 19) The study area shall be up to a distance of 10 km from the boundary of the proposed project site.
- 20) Location of the project site and nearest habitats with distances from the project site to be demarcated on a toposheet (1: 50000 scale).
- 21) Landuse based on satellite imagery including location specific sensitivities such as national parks / wildlife sanctuary, villages, industries, *etc.* for the study area.
- 22) Demography details of all the villages falling within the study area.
- 23) Topography details of the project area.
- 24) The baseline data to be collected from the study area w.r.t. different components of environment viz. air, noise, water, land, and biology and socio-economic (please refer Section 4.4.2 for guidance for assessment of baseline components and identify attributes of concern). Actual monitoring of baseline environmental components shall be strictly according to the parameters prescribed in the ToR after considering the proposed coverage of parameters by the proponent in draft ToR and shall commence after finalization of ToR by the competent Authority.
- 25) Geological features and geo-hydrological status of the study area.
- 26) Surface water quality of nearby water sources and other surface drains.
- 27) Details on ground water quality around the plant and compost yard.
- 28) Details on water quality for the parameters such as Temperature, Colour, pH, BOD, COD, Total Suspended Solids, TDS, Total Kjeldhal Nitrogen, Phosphates, Oil & Grease, Total Coliform bacteria *etc.*

- 29) Details on existing ambient air quality and expected, stack and fugitive emissions for PM<sub>10</sub>, PM<sub>2.5</sub>, SO<sub>2</sub>\*, NO<sub>x</sub>\*, carbon oxides (CO and CO<sub>2</sub>), *etc.*, and evaluation of the adequacy of the proposed pollution control devices to meet standards for point sources and to meet AAQ standards. (\* - As applicable)
- 30) The air quality contours may be plotted on a location map showing the location of project site, habitation nearby, sensitive receptors, if any and wind roses.
- 31) Details on noise levels at sensitive/commercial receptors.
- 32) Site-specific micro-meteorological data including mixing height.
- 33) One season site-specific data excluding monsoon season.
- 34) Proposed baseline monitoring network for the consideration and approval of the Competent Authority.
- 35) Ecological status (terrestrial and aquatic) of the study area such as habitat type and quality, species, diversity, rarity, fragmentation, ecological linkage, age, abundance, *etc.*
- 36) If any incompatible land use attributes fall within the study area, proponent shall describe the sensitivity (distance, area and significance) and propose the additional points based on significance for review and acceptance by the EAC/SEAC. Incompatible land use attributes include:
  - Public water supply areas from rivers/surface water bodies, from ground water
  - Scenic areas/tourism areas/hill resorts
  - Religious places, pilgrim centers that attract over 10 lakh pilgrims a year
  - Protected tribal settlements (notified tribal areas where industrial activity is not permitted)
  - CRZ (Coastal Regulatory Zone)
  - Monuments of national significance, World Heritage Sites
  - Cyclone, Tsunami prone areas (based on last 25 years)
  - Airport areas
  - Any other feature as specified by the State or local government and other features as locally applicable, including prime agricultural lands, pastures, migratory corridors, *etc.*
- 37) If ecologically sensitive attributes fall within a 5 km radius of the project boundary, proponent shall describe the sensitivity (distance, area and significance) and propose the additional points based on significance for review and acceptance by the EAC/SEAC. Ecological sensitive attributes include:
  - National parks
  - Wild life sanctuaries Game reserve
  - Mangrove area
  - Wetlands
  - Reserved and Protected forests, *etc.*,
  - Any other closed/protected area under the Wild Life (Protection) Act, 1972, any other area locally applicable
- 38) If the location falls in a valley, specific issues connected to the management of natural resources shall be studied and presented.
- 39) If the location falls in CRZ area: A CRZ map duly authenticated by one of the authorized agencies demarcating LTL, HTL, CRZ area, location of the project and associate facilities w.r.t. CRZ, coastal features such as mangroves, if any.

- Provide the CRZ map in 1:10000 scale in general cases and in 1:5000 scale for specific observations.
- Proposed site for disposal of dredged material and environmental quality at the point of disposal/impact areas.
- Fisheries study should be done w.r.t. Benthos and Marine organic material and coastal fisheries.

### Anticipated environmental impacts & mitigation measures

- 40) Anticipated generic environmental impacts due to this project are indicated in Table 4-2, which may be evaluated for significance and based on corresponding likely impacts VECs may be identified. Baseline studies may be conducted for all the concerned VECs and likely impacts will have to be assessed for their magnitude in order to identify mitigation measures (please refer Chapter 4 of the manual for guidance).
- 41) Tools as given in Section 4.4.3 may be referred for the appropriate assessment of environmental impacts and same may be submitted in draft ToR for consideration and approval by EAC/SEAC.
- 42) While identifying the likely impacts, also include the following for analysis of significance and required mitigation measures:
  - impacts due to transportation of raw materials and end products on the surrounding environment
  - impacts on surface water, soil and groundwater
  - impacts due to air pollution
  - impacts due to odour pollution
  - impacts due to noise
  - impacts due to fugitive emissions
  - impact on health of workers due to proposed project activities
- 43) Impact on drainage of the area and the surroundings.
- 44) Proposed measures for occupational safety and health of the workers.
- 45) Proposed odour control measures.
- 46) Action plan for the greenbelt development – species, width of plantations, planning schedule etc. in accordance to CPCB published guidelines.
- 47) In case of likely impact from the proposed project on the surrounding reserve forests, Plan for the conservation of wild fauna in consultation with the State Forest Department.
- 48) For identifying the mitigation measures, please refer Chapter III for source control and treatment. Besides typical mitigation measures which may also be considered are discussed in Table 4-5.

### Analysis of alternative resources and technologies

- 49) Comparison of alternate sites considered and the reasons for selecting the proposed site. Conformity of the site with the prescribed guidelines in terms of CRZ, river, highways, railways *etc.*
- 50) Details on improved technologies.
- 51) Details on proposed recovery options.



### **Environmental monitoring program**

- 52) Monitoring programme for pollution control at source.
- 53) Monitoring pollutants at receiving environment for the appropriate notified parameters – air quality, groundwater, surface water, *etc.* during operational phase of the project.
- 54) Specific programme to monitor safety and health protection of workers.
- 55) Appropriate monitoring network has to be designed and proposed, to assess the possible residual impacts on VECs.
- 56) Details of in-house monitoring capabilities and the recognized agencies if proposed for conducting monitoring.

### **Additional studies**

- 57) Details on risk assessment and damage control during different phases of the project and proposed safeguard measures.
- 58) Details on socio-economic development activities such as commercial property values, generation of jobs, education, social conflicts, cultural status, accidents, *etc.*
- 59) Proposed plan to handle the socio-economic influence on the local community. The plan should include quantitative dimension as far as possible.
- 60) Details on compensation package for the people affected by the project, considering the socio-economic status of the area, homestead oustees, land oustees, and landless labourers.
- 61) Points identified in the public hearing and commitment of the project proponent to the same. Detailed action plan addressing the issues raised, and the details of necessary allocation of funds.

### **Environmental management plan**

- 62) Administrative and technical organizational structure to ensure proposed post-project monitoring programme for approved mitigation measures.
- 63) EMP devised to mitigate the adverse impacts of the project should be provided along with item-wise cost of its implementation (capital and recurring costs).
- 64) Allocation of resources and responsibilities for plan implementation.
- 65) Details of the emergency preparedness plan and on-site and off-site disaster management plan.

Note:

*Above points shall be adequately addressed in the EIA report at corresponding chapters, in addition to the contents given in the reporting structure (Table 4-6).*

## **4.4 Environmental Impact Assessment**

The approach for accomplishing EIA studies is shown in Figure 4.3. Each stage is discussed, in detail in subsequent sections.

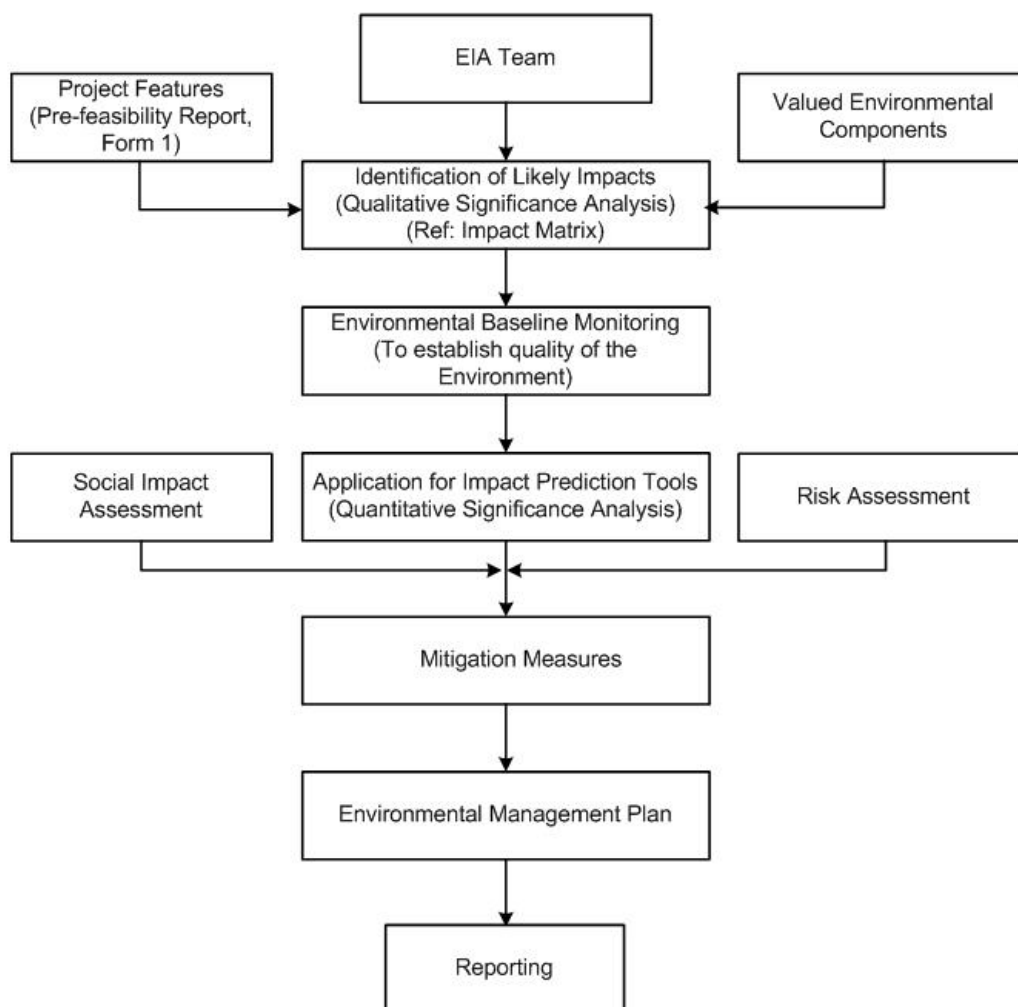

Figure 4-3: Approach for EIA Study

#### 4.4.1 EIA team

The success of a multi-functional activity like an EIA primarily depends on constitution of a right team at the right time (preferable at the initial stages of an EIA) in order to assess the significant impacts (direct, indirect as well as cumulative impacts).

The professional Team identified for a specific EIA study should consist of qualified and experienced professionals from various disciplines, in order to address the critical aspects identified for the specific project. Based on the nature and the environmental setting, following professionals may be identified for EIA studies:

- Environmental management specialist/ environmental regulator
- Air and Noise quality
- Occupational health
- Geology/geo-hydrology
- Ecologist
- Transportation specialist
- Safety and health specialist
- Social scientist
- Organic chemistry specialist, *etc.*

#### 4.4.2 Baseline quality of the environment

EIA Notification 2006 specifies that an EIA Report should contain a description of the existing environment that would be or might be affected directly or indirectly by the proposed project. Environmental Baseline Monitoring (EBM) is a very important stage of EIA. On one hand EBM plays a very vital role in EIA and on the other hand it provides feedback about the actual environmental impacts of a project. EBM during the operational phase helps in judging the success of mitigation measures in protecting the environment. Mitigation measures, in turn are used to ensure compliance with environmental standards, and to facilitate any needed project design or operational changes.

Description of the existing environment should include natural, cultural, socio-economic systems and their interrelationships. The intention is not to describe all baseline conditions, but to focus the collection and description of baseline data on those VECs that are important and are affected by the proposed distillery project activity.

##### 4.4.2.1 Objective of EBM in the EIA context

The term ‘baseline’ refers to conditions existing before development against which subsequent changes can be referenced. EBM studies are carried out to:

- Identify environmental conditions which might influence project design decisions (e.g., site layout, structural or operational characteristics)
- Identify sensitive issues or areas requiring mitigation or compensation
- Provide input data to analytical models used for predicting effects
- Provide baseline data against which the results of future monitoring programs can be compared

At this stage of EIA process, EBM is primarily discussed in the context of first purpose wherein feedback from EBM programs may be used to:

- determine available assimilative capacity of different environmental components within the designated impact zone and whether more or less stringent mitigation measures are needed; and
- improve predictive capability of EIAs.

There are many institutional, scientific, quality control, and fiscal issues that must be addressed in implementation of an environmental monitoring program. Careful consideration of these issues in the design and planning stages will avoid many of the pitfalls associated with environmental monitoring programs.

##### 4.4.2.2 Environmental monitoring network design

Monitoring refers to the collection of data through a series of repetitive measurements of environmental parameters (or, more generally, to a process of systematic observation). Design of the environmental quality monitoring programme depends up on the monitoring objectives specified for the selected area of interest. Types of monitoring and network design considerations are discussed in **Annexure VII**.

### 4.4.2.3 Baseline data generation

List of important physical environmental components and indicators of EBM are given in Table 4-3.

**Table 4-3: List of Important Physical Environment Components and Indicators of EBM**

Environmental Component	Environmental Indicators
Climatic variables	<ul style="list-style-type: none"> <li>▪ Rainfall patterns – mean, mode, seasonality</li> <li>▪ Temperature patterns</li> <li>▪ Extreme events</li> <li>▪ Climate change projections</li> <li>▪ Prevailing wind - direction, speed, anomalies</li> <li>▪ Relative humidity</li> <li>▪ Stability conditions and mixing height, <i>etc.</i></li> </ul>
Topography	<ul style="list-style-type: none"> <li>▪ Slope form</li> <li>▪ Landform and terrain analysis</li> <li>▪ Specific landform types, <i>etc.</i></li> </ul>
Drainage	<ul style="list-style-type: none"> <li>▪ Surface hydrology</li> <li>▪ Natural drainage pattern and network</li> <li>▪ Rainfall runoff relationships</li> <li>▪ Hydrogeology</li> <li>▪ Groundwater characteristics – springs, <i>etc.</i></li> </ul>
Soil	<ul style="list-style-type: none"> <li>▪ Type and characteristics</li> <li>▪ Porosity and permeability</li> <li>▪ Sub-soil permeability</li> <li>▪ Run-off rate</li> <li>▪ Infiltration capacity</li> <li>▪ Effective depth (inches/centimeters)</li> <li>▪ Inherent fertility</li> <li>▪ Suitability for method of sewage disposal, <i>etc.</i></li> </ul>
Geology	<ul style="list-style-type: none"> <li>▪ Underlying rock type, texture</li> <li>▪ Surgical material</li> <li>▪ Geologic structures (faults, shear zones, <i>etc.</i>)</li> <li>▪ Geologic resources (minerals, <i>etc.</i>)</li> </ul>
Water	<ul style="list-style-type: none"> <li>▪ Raw water availability</li> <li>▪ Water quality</li> <li>▪ Surface water (rivers, lakes, ponds, gullies) – quality, water depths, flooding areas, <i>etc.</i></li> <li>▪ Ground water – water table, local aquifer storage capacity, specific yield, specific retention, water level depths and fluctuations, <i>etc.</i></li> <li>▪ Coastal</li> <li>▪ Floodplains</li> <li>▪ Wastewater discharges</li> <li>▪ Waste discharges, <i>etc.</i></li> </ul>
Air	<ul style="list-style-type: none"> <li>▪ Ambient</li> <li>▪ Respirable</li> <li>▪ Airshed importance</li> <li>▪ Odour levels, <i>etc.</i></li> </ul>
Noise	<ul style="list-style-type: none"> <li>▪ Identifying sources of noise</li> <li>▪ Noise due to traffic/transportation of vehicles</li> </ul>

Environmental Component	Environmental Indicators
	<ul style="list-style-type: none"> <li>▪ Noise due to heavy equipment operations</li> <li>▪ Duration and variations in noise over time, <i>etc.</i></li> </ul>
Coastal dynamics and morphology	<ul style="list-style-type: none"> <li>▪ Wave patterns</li> <li>▪ Currents</li> <li>▪ Shoreline morphology – near shore, foreshore</li> <li>▪ Sediment – characteristics and transport, <i>etc.</i></li> </ul>
Biological	<ul style="list-style-type: none"> <li>▪ Species composition of flora and fauna</li> <li>▪ Flora – type, density, exploitation, <i>etc.</i></li> <li>▪ Fauna – distribution, abundance, rarity, migratory, species diversity, habitat requirements, habitat resilience, economic significance, commercial value, <i>etc.</i></li> <li>▪ Fisheries – migratory species, species with commercial/recreational value, <i>etc.</i></li> </ul>
Landuse	<ul style="list-style-type: none"> <li>▪ Landuse pattern, <i>etc.</i></li> </ul>

Guidance for assessment of baseline components and attributes describing sampling network, sampling frequency, method of measurement is given in **Annexure VIII**.

### Infrastructure requirements for EBM

In addition to devising a monitoring network design and monitoring plans/program, it is also necessary to ensure adequate resources in terms of staffing and skills, equipment, training, budget, *etc.*, for its implementation. Besides assigning institutional responsibility, reporting requirements, QA/QC plans and its enforcement capability are essential. A monitoring program that does not have an infrastructural support and QA/QC component will have little chance of success.

### Defining data statistics/analyses requirements

The data analyses to be conducted are dictated by the objectives of the environmental monitoring program. Statistical methods used to analyze data should be described in detail prior to data collection. This is important because repetitive observations are recorded in time and space. Besides, the statistical methods could also be chosen so that uncertainty or error estimates in the data can be quantified. For *e.g.*, statistical methods useful in an environmental monitoring program include: 1) frequency distribution analysis; 2) analysis of variance; 3) analysis of covariance; 4) cluster analysis; 5) multiple regression analysis; 6) time series analysis; 7) the application of statistical models (ADB-Green, 1979).

### Use of secondary data

The EBM program for EIA can at best address temporal and/or spatial variations limited to a limited extent because of cost implications and time limitations. Therefore analysis of all available information or data is essential to establish the regional profiles. So all the relevant secondary data available for different environmental components should be collated and analyzed.

To facilitate stake-holders, IL&FS Ecosmart Ltd., has made an attempt to compile the list of information required for EIA studies and sources of secondary data, which are given in **Annexure IXA** and **Annexure IXB**.

#### 4.4.3 Impact prediction tools

The scientific and technical credibility of an EIA relies on the ability of the EIA practitioners to estimate the nature, extent, and magnitude of change in environmental components that may result from project activities. Information about predicted changes is needed for assigning impact significance, prescribing mitigation measures, and designing and developing EMPs and monitoring programs. The more accurate the predictions, the more confident the EIA practitioner will be in prescribing specific measures to eliminate or minimize the adverse impacts of development project.

Choice of models/methods for impact predictions in respect to air, noise, water, land, biological and socio-economic environment are tabulated in **Annexure X**.

#### 4.4.4 Significance of the impacts

Evaluating the significance of environmental effects is perhaps the most critical component of impact analysis. More than other components, however, the interpretation of significance is also a contentious process. The interpretation of significance bears directly on the subsequent EIA process and also during environmental clearance on project approvals and condition setting. At an early stage, it also enters into screening and scoping decisions on what level of assessment is required and which impacts and issues will be addressed.

Impact significance is also a key to choosing among alternatives. In total, the attribution of significance continues throughout the EIA process, from scoping to EIS review, in a gradually narrowing “cone of resolution” in which one stage sets up the next. But at this stage it is the most important as better understanding and quantification of impact significance is required.

One common approach is based on determination of the significance of predicted changes in the baseline environmental characteristics and compares these with reference to regulatory standards, objective criteria and similar ‘thresholds’ as eco-sensitivity, cultural /religious values. Often, these are outlined in guidance. A better test proposed by the CEAA (1995) is to determine if ‘residual’ environmental effects are adverse, significant, and likely (given under). But at this stage, the practice of formally evaluating significance of residual impacts, *i.e.*, after predicting the nature and magnitude of impacts based on before-versus-after-project comparisons, and identifying measures to mitigate these effects is not being followed in a systematic way.

##### **Step 1: Are the environmental effects adverse?**

Criteria for determining if effects are “adverse” include:

- Effects on biota health
- Effects on rare or endangered species
- Reductions in species diversity
- Habitat loss
- Transformation of natural landscapes
- Effects on human health
- Effects on current use of lands and resources for traditional purposes by aboriginal persons; and
- Foreclosure of future resource use or production

## Step 2: Are the adverse environmental effects significant?

Criteria for determining ‘significance’ are to judge that the impacts:

- Are extensive over space or time
- Are intensive in concentration or proportion to assimilative capacity
- Exceed environmental standards or thresholds
- Do not comply with environmental policies, landuse plans, sustainability strategy
- Adversely and seriously affect ecologically sensitive areas
- Adversely and seriously affect heritage resources, other landuses, community lifestyle and/or indigenous peoples traditions and values

## Step 3: Are the significant adverse environmental effects likely?

Criteria for determining ‘likelihood’ include:

- Probability of occurrence, and
- Scientific uncertainty

## 4.5 Social Impact Assessment

Social Impact Assessment (SIA) is an instrument used to analyze social issues and solicit stakeholder views for the design of projects. SIA helps in making the project responsive to social development concerns, including options that enhance benefits for poor and vulnerable people while mitigating risk and adverse impacts. It analyzes distributional impacts of intended project benefits on different stakeholder groups, and identifies differences in assets and capabilities to access the project benefits.

The scope and depth of SIA should be determined by the complexity and importance of the issues studied, taking into account the skills and resources available. SIA should include studies related to involuntary resettlement, compulsory land acquisition, impact of imported workforces, job losses among local people, damage to sites of cultural, historic or scientific interest, impact on minority or vulnerable groups, child or bonded labour, use of armed security guards. However, SIA may primarily include the following::

### Description of the Socio-economic, Cultural and Institutional Profile

Conduct a rapid review of available sources of information to describe the socio-economic, cultural and institutional interface in which the project operates.

**Socio-economic and cultural profile:** Describe the most significant social, economic and cultural features that differentiate social groups in the project area. Describe their different interests in the project, and their levels of influence. Explain specific effects the project may have on the poor and underprivileged. Identify any known conflicts among groups that may affect project implementation.

**Institutional profile:** Describe the institutional environment; consider both the presence and function of public, private and civil society institutions relevant to the operation. Are there important constraints within existing institutions *e.g.* disconnect between institutional responsibilities and the interests and behaviors of personnel within those institutions? Or are there opportunities to utilize the potential of existing institutions, *e.g.* private or civil society institutions, to strengthen implementation capacity

## Legislative and regulatory considerations

To review laws and regulations governing the project's implementation and access of poor and excluded groups to goods, services and opportunities provided by the project. In addition, review the enabling environment for public participation and development planning. Social analysis should build on strong aspects of legal and regulatory systems to facilitate program implementation and identify weak aspects while recommending alternative arrangements.

## Key social issues

SIA provides baseline information for designing the social development strategy. The analysis should determine the key social and Institutional issues which affect the project objectives; identify the key stakeholder groups in this context and determine how relationships between stakeholder groups will affect or be affected by the project; and identify expected social development outcomes and actions proposed to achieve those outcomes.

## Data collection and methodology

Describe the design and methodology for social analysis. In this regard:

- Build on existing data;
- Clarify the units of analysis for social assessment: intra-household, household level, as well as communities/settlements and other relevant social aggregations on which data is available or will be collected for analysis;
- Choose appropriate data collection and analytical tools and methods, employing mixed methods wherever possible; mixed methods include a mix of quantitative and qualitative methods.

## Strategy to achieve social development outcomes

Identify the likely social development outcomes of the project and propose a social development strategy, including recommendations for institutional arrangements to achieve them, based on the findings of the social assessment. The social development strategy could include measures that:

- strengthen social inclusion by ensuring inclusion of both poor and excluded groups and intended beneficiaries are included in the benefit stream; offer access to opportunities created by the project
- empower stakeholders through their participation in the design and implementation of the project, their access to information, and their increased voice and accountability (*i.e.* a participation framework); and
- enhance security by minimizing and managing likely social risks and increasing the resilience of intended beneficiaries and affected persons to socioeconomic shocks

## Implications for analysis of alternatives

Review proposed approaches for the project, and compare them in terms of their relative impacts and social development outcomes. Consider what implications the findings of the social assessment might have on those approaches. Should some new components be added to the approach, or other components be reconsidered or modified?



If SIA and consultation processes indicate that alternative approaches may have better development outcomes, such alternatives should be described and considered, along with the likely budgetary and administrative effects these changes might have.

### **Recommendations for project design and implementation arrangements**

Provide guidance to project management and other stakeholders on how to integrate social development issues into project design and implementation arrangements. As much as possible, suggest specific action plans or implementation mechanisms to address relevant social issues and potential impacts. These can be developed as integrated or separate action plans, for example, as Resettlement Action Plans, Indigenous Peoples Development Plans, Community Development Plans, *etc.*

### **Developing a monitoring plan**

Through SIA process, a framework for monitoring and evaluation should be developed. To the extent possible, this should be done in consultation with key stakeholders, especially beneficiaries and affected people. The framework shall identify expected social development indicators, establish benchmarks, and design systems and mechanisms for measuring progress and results related to social development objectives. The framework shall identify organizational responsibilities in terms of monitoring, supervision, and evaluation procedures. Where possible, participatory monitoring mechanisms shall be incorporated. The framework should

- a set of monitoring indicators to track the progress achieved. The benchmarks and indicators should be limited in number, and should combine both quantitative and qualitative types of data. Indicators for outputs to be achieved by the social development strategy should include indicators to monitor the process of stakeholder participation, implementation and institutional reform
- indicators to monitor social risk and social development outcomes; and indicators to monitor impacts of the project's social development strategy. It is important to suggest mechanisms through which lessons learnt from monitoring and stakeholder feedback can result in changes to improve the operation of the project. Indicators should be of such a nature that results and impacts can be disaggregated by gender and other relevant social groups
- define transparent evaluation procedures. Depending on context, these may include a combination of methods, such as participant observation, key informant interviews, focus group discussions, census and socio-economic surveys, gender analysis, Participatory Rural Appraisal (PRA), Participatory Poverty Assessment (PPA) methodologies, and other tools. Such procedures should be tailored to the special conditions of the project and to the different groups living in the project area; Estimate resource and budget requirements for monitoring and evaluation activities, and a description of other inputs (such as institutional strengthening and capacity building) needs to be carried out

## **4.6 Risk Assessment**

Industrial accidents results in great personal and financial loss. Managing these accidental risks in today's environment is the concern of every industry including distillery units, because either real or perceived incidents can quickly jeopardize the financial viability of a business. Many facilities involve various manufacturing processes

that have the potential for accidents which may be catastrophic to the plant, work force, environment, or public.

The main objective of risk assessment study is to propose a comprehensive but simple approach to carry out risk analysis and conducting feasibility studies for industries, planning and management of industrial prototype hazard analysis study in Indian context.

Risk analysis and risk assessment (Figure 4-4) should provide details on Quantitative Risk Assessment (QRA) techniques used world-over to determine risk posed to people who work inside or live near hazardous facilities, and to aid in preparing effective emergency response plans by delineating a Disaster Management Plan (DMP) to handle onsite and offsite emergencies. Hence, QRA is an invaluable method for making informed risk-based process safety and environmental impact planning decisions, as well as being fundamental to any decision for siting a facility. QRA whether, site-specific or risk-specific for any plant is complex and needs extensive study that involves process understanding, hazard identification, consequence modeling, probability data, vulnerability models/data, local weather and terrain conditions and local population data. QRA may be carried out to serve the following objectives:

- Identification of safety areas
- Identification of hazard sources
- Generation of accidental release scenarios for escape of hazardous materials from the facility
- Identification of vulnerable units with recourse to hazard indices
- Estimation of damage distances for the accidental release scenarios with recourse to Maximum Credible Accident (MCA) analysis
- Hazard and Operability studies (HAZOP) in order to identify potential failure cases of significant consequences
- Estimation of probability of occurrences of hazardous event through fault tree analysis and computation of reliability of various control paths
- Assessment of risk on basis of above evaluation against the risk acceptability criteria relevant to the situation
- Suggest risk mitigation measures based on engineering judgement, reliability and risk analysis approaches
- Delineation / up-gradation of Disaster Management Plan (DMP)
- Safety Reports: with external safety report/ occupational safety report

The risk assessment report may cover the following in terms of the extent of damage with resource to MCA analysis and delineation of risk mitigations measures with an approach to DMP.

- Hazard identification – identification of hazardous activities, hazardous materials, past accident records, *etc.*
- Hazard quantification – consequence analysis to assess the impacts
- Risk Presentation
- Risk Mitigation Measures
- DMPs

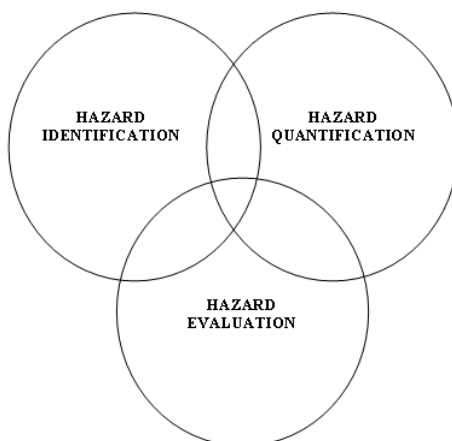

**Figure 4-4: Risk Assessment – Conceptual Framework**

Methods of risk prediction should cover all the design intentions and operating parameters to quantify risk in terms of probability of occurrence of hazardous events and magnitude of its consequence. Table 4-4 shows the predicted models for risk assessment.

**Table 4-4: Guidance for Accidental Risk Assessment**

Name	Application	Remarks
EFFECT  WHAZAN	Consequence Analysis for Visualization of accidental chemical release scenarios & its consequence  Consequence Analysis for Visualization of accidental chemical release scenarios & its consequence	Heat load, press wave & toxic release exposure neutral gas dispersion
EGADIS	Consequence Analysis for Visualization of accidental chemical release scenarios & its consequence	Dense gas dispersion
HAZOP and Fault Tree Assessment	For estimating top event probability	Failure frequency data is required
Pathways reliability and protective system hazard analysis	For estimating reliability of equipments and protective systems	Markov models
Vulnerability Exposure models	Estimation of population exposure	Uses probit equation for population exposure
F-X and F-N curves	Individual / Societal risks	Graphical Representation

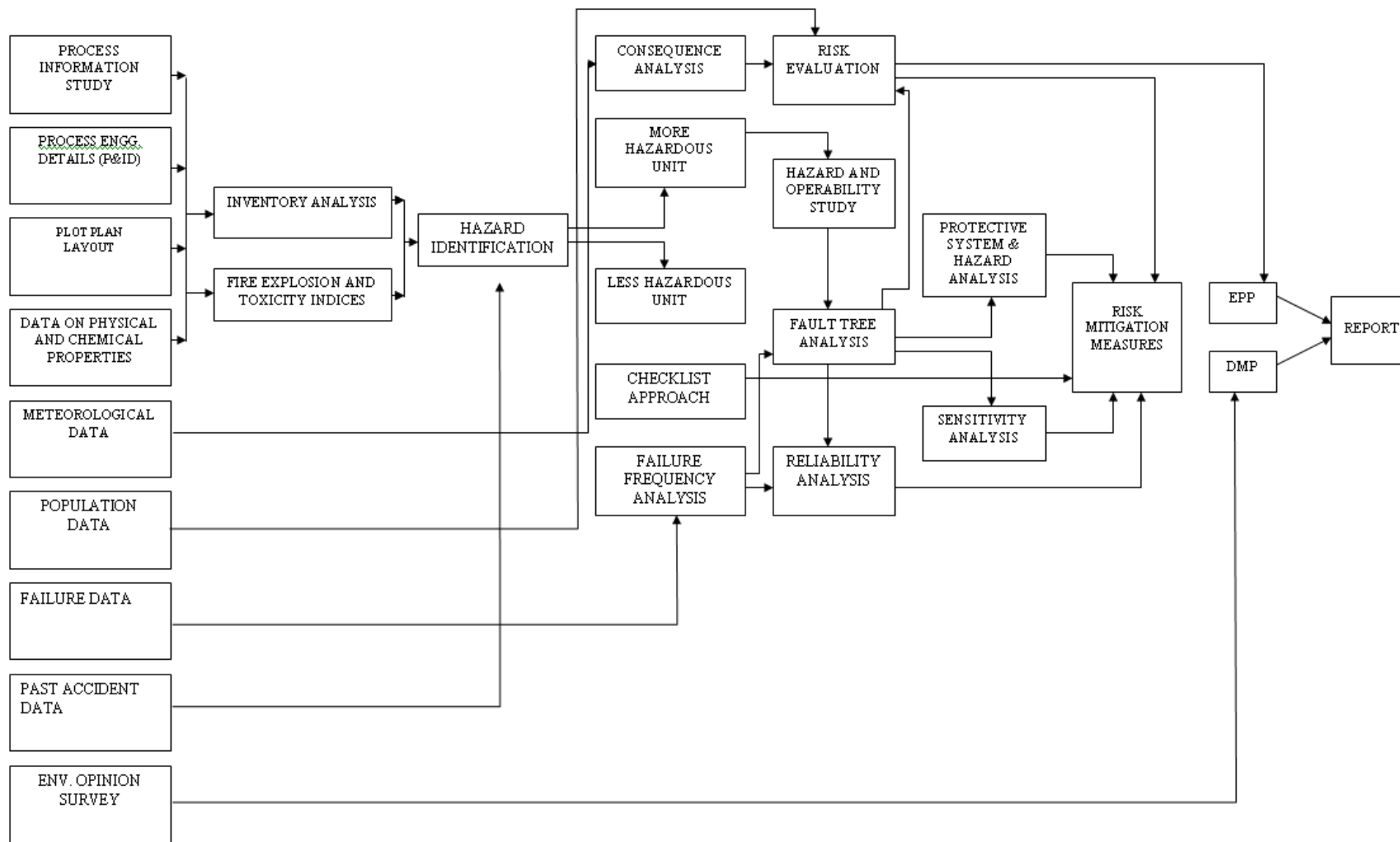

Figure 4-5: Comprehensive Risk Assessment - At a Glance

#### 4.6.1 Disaster management plan

A disaster is a catastrophic situation in which suddenly, people are plunged into helplessness and suffering and, as a result, need protection, clothing, shelter, medical and social care and other necessities of life.

DMP is aimed to ensure safety of life, protection of environment, protection of installation, restoration of production and salvage operations in this same order of priorities. For effective implementation of DMP, it should be widely circulated and a personnel training is to be provided through rehearsals/drills.

To tackle the consequences of a major emergency inside the plant or immediate vicinity of the plant, a Disaster Management Plan has to be formulated and this planned emergency document is called “Disaster Management Plan”.

The objective of DMP is to make use of the combined resources of the plant and the outside services to achieve the following:

- Effective rescue and medical treatment of casualties
- Safeguard other people
- Minimize damage to property and the environment
- Initially contain and ultimately bring the incident under control
- Identify any dead
- Provide for the needs of relatives
- Provide authoritative information to the news media
- Secure the safe rehabilitation of affected area
- Preserve relevant records and equipment for the subsequent inquiry into the cause and circumstances of the emergency

In effect, it is to optimize operational efficiency to rescue rehabilitation and render medical help and to restore normalcy.

DMP should include Emergency Preparedness Plan, Emergency Response Team, Emergency Communication, Emergency Responsibilities, Emergency Facilities, and Emergency Actions

#### Emergency preparedness plan

Incidents, accidents and contingency preparedness should be accounted during construction and operation process. This shall be a part of EMS. Emergency Preparedness Plan (EPP) should be prepared following the National Environmental Emergency Plan and OSHA guidelines. According to these guidelines, an environmental emergency plan would essentially provide the following information:

- Assignment of duties and responsibilities among the authorities, participating agencies, response team, their coordinators and/or those responsible for the pollution incident
- Relationship with other emergency plans
- A reporting system that ensures rapid notification in the event of a pollution incident
- The establishment of a focal point for coordination and directions connected to the implementation of the plan

- Response operations should always cover these four phases:
  - Discovery and alarm
  - Evaluation, notification and plan invocation
  - Containment and countermeasures
  - Cleanup and disposal
- Identification of expertise and response resources available for assistance for the implementation of plan
- Directions on necessary emergency provisions applicable to the handling, treatment or disposal of certain pollutants
- Link to the local community for assistance, if necessary
- Support measures, such as procedures for providing public information, carrying out surveillance, issuing post-incident reports, review and updating of the plan, and periodic exercising of the plan.

### **Emergency response**

Various industrial activities within the project facility are always subjected to accidents and incidents of many a kind. Therefore, a survey of potential incidents and accidents is to be carried out. Based on this, a plan for response to incidents, injuries and emergencies should be prepared. Response to emergencies should ensure that:

- The exposure of workers should be limited as much as possible during the operation
- Contaminated areas should be cleaned and if necessary disinfected
- Limited impact on the environment at the extent possible

Written procedures for different types of emergencies should be prepared and the entire workforce should be trained in emergency response. All relevant emergency response equipment should also be readily available.

With regard to dangerous spills, associated cleanup and fire fighting operations should be carried out by specially allocated and trained personnel.

### **Response team**

It is important to setup an Emergency Organization. A senior executive who has control over the affairs of the plant would be heading the Emergency Organization. He would be designated as Site Controller. Manager (Safety) would be designated as the Incident Controller. In case of stores, utilities, open areas, which are not under control of the Production Heads, Senior Executive responsible for maintenance of utilities would be designated as Incident Controller. All the Incident Controllers would be reporting to the Site Controller.

Each Incident Controller organizes a team responsible for controlling the incidence with the personnel under his control. Shift in charge would be reporting officer, who would bring the incidence to the notice of the Incidence Controller and Site Controller.

Emergency Coordinators would be appointed who would undertake the responsibilities like firefighting, rescue, rehabilitation, transport and provide essential & support services.

For this purposes, Security In charge, Personnel Department, Essential services personnel would be engaged. All these personnel would be designated as key personnel.

In each shift, electrical supervisor, electrical fitters, pump house in charge, and other maintenance staff would be drafted for emergency operations. In the event of power or communication system failure, some of staff members in the office/facility would be drafted and their services would be utilized as messengers for quick passing of communications. All these personnel would be declared as essential personnel.

### **Response to injuries**

Based on a survey of possible injuries, a procedure for response to injuries or exposure to hazardous substances should be established. All staff should have minimum of training to such response and the procedure ought to include the following:

- Immediate first aid, such as eye splashing, cleansing of wounds and skin, and bandaging
- Immediate reporting to a responsible designated person
- If possible, retention of the item and details of its source for identification of possible hazards
- Rapid additional medical care from medical personnel
- Medical surveillance
- Recording of the incident
- Investigation, determination and implementation of remedial action

It is vital that incident reporting should be straightforward so that reporting is actually carried out.

### **Emergency communication**

Whoever notices an emergency situation such as fire, growth of fire, leakage etc. would inform his immediate superior and Emergency Control Center. The person on duty in the Emergency Control Center, would appraise the Site Controller. Site Controller verifies the situation from the Incident Controller of that area or the Shift In charge and takes a decision about an impending On-site Emergency. This would be communicated to all the Incident Controllers, Emergency Coordinators. Simultaneously, the emergency warning system would be activated on the instructions of the Site Controller.

### **Emergency responsibilities**

The responsibilities of the key personnel should be defined for the following:

- Site controller
- Incident controller
- Emergency coordinator - rescue, fire fighting
- Emergency coordinator-medical, mutual aid, rehabilitation, transport and communication
- Emergency coordinator - essential services

- Employers responsibility

### Emergency facilities

- Emergency Control Center – with access to important personnel, telephone, fax, telex facility, safe contained breathing apparatus, hand tools, emergency shut down procedures, duties and contact details of key personnel and government agencies, emergency equipments, *etc.*
- Assembly Point – with minimum facilities for safety and rescue
- Emergency Power Supply – connected with diesel generator, flame proof emergency lamps, *etc.*
- Fire Fighting Facilities – first aid fire fighting equipments, fire alarms, *etc.*
- Location of wind Stock – located at appropriate location to indicate the direction of wind for emergency escape
- Emergency Medical Facilities – Stretchers, gas masks, general first aid, emergency control room, breathing apparatus, other emergency medical equipment, ambulance

### Emergency actions

- Emergency warning
- Evacuation of Personnel
- All Clear Signal
- Public information and warning
- Coordination with local authorities
- Mutual aid
- Mock drills

## 4.7 Mitigation Measures

The purpose of mitigation is to identify measures that safeguard the environment and the community affected by the proposal. Mitigation is both a creative and practical phase of the EIA process. It seeks to find the best ways and means of avoiding, minimizing and remedying impacts. Mitigation measures must be translated into action in the right way and at the right time, if they are to be successful. This process is referred to as impact management and takes place during project implementation. A written plan should be prepared for this purpose, and should include a schedule of agreed actions. Opportunities for impact mitigation will occur throughout the project cycle.

### 4.7.1 Important considerations for mitigation methods

The responsibility of project proponents to ‘internalize’ the full environmental costs of development proposals is now widely accepted under “Polluter Pay” principle. In addition, many proponents have found that good design and impact management can result in significant savings applying the principles of cleaner production to improve their environmental performance.

- The predicted adverse environmental as well as social impacts for which mitigation measures are required should be identified and briefly summarized along with cross



referencing them to the significance, prediction components of the EIA report or other documentation.

- Each mitigation measure should be briefly described w.r.t the impact of significances to which it relates and the conditions under which it is required (for example, continuously or in the event of contingencies). These should also be cross-referenced to the project design and operating procedures which elaborate on the technical aspects of implementing the various measures.
- Cost and responsibilities for mitigation and monitoring should be clearly defined, including arrangements for coordination among the various Authorities responsible for mitigation.
- The proponent can use the EMP to develop environmental performance standards and requirements for the project site as well as supply chain. An EMP can be implemented through EMS for the operational phase of the project.

Prior to selecting mitigation plans it is appropriate to study the mitigation alternatives for cost-effectiveness, technical and socio-political feasibility. Such mitigation measures could include:

- Avoiding sensitive areas such as eco-sensitive area *e.g.* fish spawning areas, dense mangrove areas or areas known to contain rare or endangered species
- Adjusting work schedules to minimize disturbance
- Engineered structures such as berms and noise attenuation barriers
- Pollution control devices, such as scrubbers and electrostatic precipitators
- Changes in fuel feed, manufacturing, process, technology use, or waste management practices, *etc.*

### **Other generic measures**

- Extend education facility and vocational training to the children of the neighbouring villages.
- Extend hospital facilities for adjacent villages and provide community with water supply.
- Develop community projects to improve rural economy, health and sanitation standards, animal husbandry, *etc.*
- Conduct mass awareness programmes for villagers, township residents and employees about the chemicals / raw materials being used in the plant, emergency preparedness of the industry, *etc.*
- Develop green belt / greenery in and around the plant.
- Develop infrastructure like roads, power supply, transport, *etc.*
- Adopt rainwater harvesting to recharge the ground water.
- Adopt accredited Environment Management Systems: ISO 14001, OHSAS – 18001.

### 4.7.2 Hierarchy of elements of mitigation plan

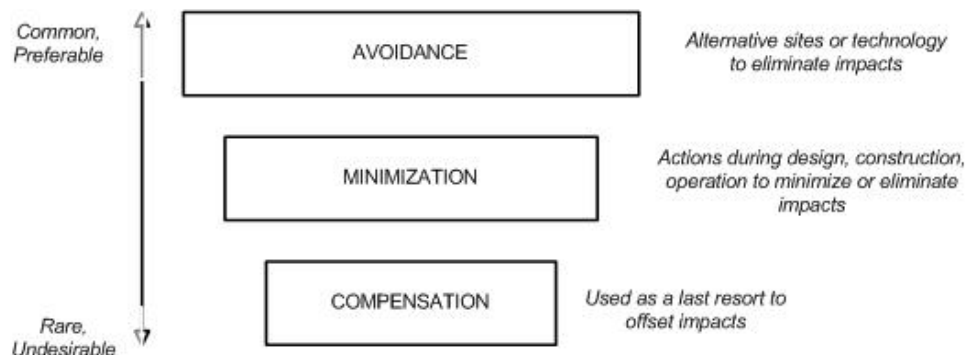

**Figure 4-6: Hierarchy of Elements of Mitigation Plan**

A good EIA practice requires technical understanding of relevant issues and the measures that work in such given circumstances. The priority of selection of mitigation measures should be in the order:

#### Step One: Impact avoidance

This step is most effective when applied at an early stage of project planning. It can be achieved by:

- Not undertaking certain projects or elements that could result in adverse impacts
- Avoiding areas that are environmentally sensitive
- Putting in place the preventative measures to stop adverse impacts from occurring, for example, release of water from a reservoir to maintain a fisheries regime

#### Step Two: Impact minimization

This step is usually taken during impact identification and prediction to limit or reduce the degree, extent, magnitude, or duration of adverse impacts. It can be achieved by:

- Scaling down or relocating the proposal
- Redesigning elements of the project
- Taking supplementary measures to manage the impacts

#### Step Three: Impact compensation

This step is usually applied to remedy unavoidable residual adverse impacts. It can be achieved by:

- Rehabilitation of the affected site or environment, for example, by habitat enhancement and restocking fish
- Restoration of the affected site or environment to its previous state or better, as typically required for mine sites, forestry roads and seismic lines
- Replacement of the same resource values at another location, for example, by wetland engineering to provide an equivalent area to that lost to drainage or infill

## Important Compensation Elements

Special considerations apply to mitigation of proposals that displace or disrupt people. Certain types of projects, such as reservoirs and irrigation schemes and public works, are known to cause involuntary resettlement. This is a contentious issue because it involves far more than re-housing people; in addition, income sources and access to common property resources are likely to be lost. Almost certainly, a resettlement plan will be required to ensure that no one is worse off than before, which may not be possible for indigenous people whose culture and lifestyle is tied to a locality. This plan must include the means for those displaced to reconstruct their economies and communities and should include an EIA of the receiving areas. Particular attention should be given to indigenous, minority and vulnerable groups who are at higher risk from resettlement.

## In-kind Compensation

When significant or net residual loss or damage to the environment is likely, in kind compensation is appropriate. As noted earlier, environmental rehabilitation, restoration or replacement have become standard practices for many proponents. Now, increasing emphasis is given to a broader range of compensation measures to offset impacts and assure the sustainability of development proposals. These include impact compensation 'trading', such as offsetting CO<sub>2</sub> emissions by planting forests to sequester carbon.

### 4.7.3 Typical mitigation measures

Choice of location for the developmental activity plays an important role in preventing adverse impacts on surrounding environment. Detailed guidelines on siting of industries are provided in Section 4.2. However, if the developmental activity still produces any more adverse impacts, mitigation measures should be taken.

Previous sub-sections of the Section 4.7 could be precisely summarized into following:

- Impacts from a developmental project could have many dimensions. As most of the direct impacts are caused by the releases from developmental projects, often control at source is the best opportunity to either eliminate or mitigate the impacts, in case these are cost-effective. In other words, the best way to mitigate the impacts is to prevent them from occurring. Choice of raw materials/technologies/processes which produce least impact would be one of the options to achieve it.
- After exploring cost-effective feasible alternatives to control impacts at source, various interventions to minimize the adverse impacts may be considered. These interventions, primarily aim at reducing the residual impacts on the VECs of the receiving environment to the acceptable concentrations.
- Degree of control at source and external interventions differs from situation-to-situation and is largely governed by techno-economic feasibility. While the regulatory bodies stress for further source control (due to high reliability), the project proponents bargain for other interventions which may be relatively cost-effective than further control at source (in any case project authority is required to meet the industry-specific standards by adopting the best practicable technologies. However, if the location demands further control at source, then the proponents are required to adopt further advanced control technologies *i.e.* towards best available control technologies). After having discussions with the project proponent, EAC/SEAC reaches to an agreed level of source control+other interventions (together called as mitigation measures in the given context) that achieve the targeted protection levels

for the VECs in the receiving environment. These levels will become the principal clearance conditions.

- Chapter 3 of this TGM offers elaborate information on cleaner technologies, waste minimization opportunities, and control technologies for various kinds of polluting parameters that emanate from this developmental activity. This information may be used to draw appropriate control measures applicable at source.

The choice of interventions for mitigation of impacts may also be numerous and depend on various factors. Mitigation measures based on location-specific suitability and some other factors are discussed in sub-sections 4.7.1 and 4.7.2. A few typical measures which may also be explored for mitigation of impacts are listed in Table 4-5.

**Table 4-5: Typical Mitigation Measures**

Impacts	Mitigation steps
Soil	<ul style="list-style-type: none"> <li>Windscreens, maintenance, and installation of ground cover</li> <li>Installation of drainage ditches</li> <li>Runoff and retention ponds</li> <li>Minimize disturbances and scarification of the surface</li> <li>Usage of appropriate monitoring and control facilities for construction equipments deployed</li> <li>Methods to reuse earth material generated during excavation</li> </ul>
Resources – fuel/construction material	<ul style="list-style-type: none"> <li>Availing resources with least impact – eco-efficiency options are applicable</li> </ul>
Deforestation	<ul style="list-style-type: none"> <li>Plant or create similar areas</li> <li>Initiate a tree planning program in other areas</li> <li>Donate land to conservationist groups</li> </ul>
Water pollution and issues	<ul style="list-style-type: none"> <li>Channeling and retention of water to reduce erosion and situation</li> <li>Collection and treatment of sewage and organic waste</li> <li>Increased recycling and reuse of water</li> <li>Use of biodegradable or otherwise readily treatable additives</li> <li>Cooling ponds, towers and canals to reduce temperatures of cooling water discharge</li> <li>Neutralization and sedimentation of wastewater</li> <li>Dewatering of sludges and appropriate disposal of solids</li> <li>Use deep well injection below potable levels</li> <li>Construct liners of ponds and solids waste disposal</li> <li>Dilute water at point of discharge</li> <li>Providing a stormwater network within the plant to prevent cross contamination with the effluents</li> <li>Spent wash: (a) Biomethanization followed by evaporation and composting if the distillery is attached with sugar unit- The compost shall be utilized on land as manure. (b) Concentration of raw spent wash/biomethanated effluent and burning it in Boiler to generate power- applicable for standalone distilleries. This technology can also be adopted by the distilleries attached to sugar industry.</li> </ul>
Dust pollution	<ul style="list-style-type: none"> <li>Wetting of roadways to reduce traffic dust and reentrained particles</li> <li>Installation of windscreens to breakup the wind flow</li> <li>Burning of refuse on days when meteorological conditions</li> </ul>

Impacts	Mitigation steps
	provide for good mixing and dispersion <ul style="list-style-type: none"> <li>▪ Providing dust collection equipment at all possible points</li> <li>▪ Maintaining dust levels within permissible limits</li> <li>▪ Provision for masks when dust level exceeds</li> </ul>
Noise pollution	<ul style="list-style-type: none"> <li>▪ Limiting certain activities</li> <li>▪ By using damping, absorption, dissipation, and deflection methods</li> <li>▪ By using common techniques such as constructing sound enclosures, applying mufflers, mounting noise sources on isolators, and/or using materials with damping properties</li> <li>▪ Performance specifications for noise represent a way to insure the procured item is controlled</li> <li>▪ Use of ear protective devices.</li> <li>▪ In case of steady noise levels above 85-dB (A), initiation of hearing conservation measures</li> <li>▪ Heavy duty muffler systems on heavy equipment</li> </ul>
Biological	<ul style="list-style-type: none"> <li>▪ Installation of systems to discourage nesting or perching of birds in dangerous environments</li> <li>▪ Increased employee awareness to sensitive areas</li> </ul>
Social	<ul style="list-style-type: none"> <li>▪ Health and safety measures for workers</li> <li>▪ Develop traffic plan that minimizes road use by workers</li> <li>▪ Upgrade roads and intersections</li> <li>▪ Provide infrastructure plan and financial support for increased demands</li> <li>▪ Construct facilities to reduce demands</li> </ul>
Occupational health and safety	<ul style="list-style-type: none"> <li>▪ Provision of worker camps with proper sanitation and medical facilities, as well as making the worker camps self-sufficient with resources like water supply, power supply, etc</li> <li>▪ Arrangement of periodic health check-ups for early detection and control of communicable diseases.</li> <li>▪ Arrangement to dispose off the wastes at approved disposal sites.</li> <li>▪ Provide preventive measures for potential fire hazards with requisite fire detection, fire-fighting facilities and adequate water storage</li> </ul>
Construction	<ul style="list-style-type: none"> <li>▪ Have a Transport Management Plan in place in order to prevent/minimize the disturbance on surrounding habitats</li> <li>▪ Initiate traffic density studies</li> </ul>
Solid/Hazardous waste	<ul style="list-style-type: none"> <li>▪ Proper handling of excavated soil</li> <li>▪ Proper plan to collect and dispose off the solid waste generated onsite.</li> <li>▪ Identify an authorized waste handler for segregation of construction and hazardous waste and its removal on a regular basis to minimise odour, pest and litter impacts</li> <li>▪ Prohibit burying of refuse onsite.</li> </ul>

#### 4.8 Environmental Management Plan

A typical EMP shall be composed of the following:

1. summary of potential impacts of the proposal

2. description of recommended mitigation measures
3. description of monitoring programme to ensure compliance with relevant standards and residual impacts
4. allocation of resources and responsibilities for plan implementation
5. implementation schedule and reporting procedures
6. contingency plan when impacts are greater than expected

**Summary of impacts:** The predicted adverse environmental and social impacts for which mitigation measures are identified in earlier sections to be briefly summarized with cross referencing to the corresponding sections in EIA report.

**Description of mitigation measures:** Each mitigation measure should be briefly described w.r.t the impact to which it relates and the conditions under which it is required. These should be accompanied by, or referenced to, project design and operating procedures which elaborate on the technical aspects of implementing the various measures.

**Description of monitoring programme to ensure compliance with relevant standards and residual impacts:** Environmental monitoring refers to compliance monitoring and residual impact monitoring. Compliance monitoring refers to meeting the industry-specific statutory compliance requirements (Ref. Applicable National regulations as detailed in Chapter 3).

Residual impact monitoring refers to monitoring of identified sensitive locations with adequate number of samples and frequency. The monitoring programme should clearly indicate the linkages between impacts identified in the EIA report, measurement indicators, detection limits (where appropriate), and definition of thresholds that signal the need for corrective actions.

**Allocation of resources and responsibilities for plan implementation:** These should be specified for both the initial investment and recurring expenses for implementing all measures contained in the EMP, integrated into the total project costs, and factored into loan negotiation.

The EMP should contain commitments that are binding on the proponent in different phases of project implementation *i.e.*, pre-construction or site clearance, construction, operation, decommissioning.

Responsibilities for mitigation and monitoring should be clearly defined, including arrangements for coordination between various actors responsible for mitigation. Details should be provided w.r.t deployment of staff (detailed organogram), monitoring network design, parameters to be monitored, analysis methods, associated equipments, *etc.*

**Implementation schedule and reporting procedures:** The timing, frequency and duration of mitigation measure should be specified in an implementation schedule, showing links with overall project implementation. Procedures to provide information on progress and results of mitigation and monitoring measures should also be clearly specified.

**Contingency Plan when the impacts are greater than expected:** There shall be a contingency plan for attending to the situations where the monitoring results shows residual impacts are higher than expected. It is an imperative requirement for all the

project authorities to plan additional programmes to deal with the situation, after duly intimating the concerned local regulatory bodies.

## 4.9 Reporting

Structure of the EIA report (Appendix III of the EIA Notification), applicable for Distillery is given in the following Table 4-6. Each task prescribed in ToR shall be incorporated appropriately in the contents in addition to the contents described in the following table.

**Table 4-6: Generic Structure of EIA Document**

S.NO	EIA STRUCTURE	CONTENTS
1.	Introduction	<ul style="list-style-type: none"> <li>▪ Purpose of the report</li> <li>▪ Identification of project &amp; project proponent</li> <li>▪ Brief description of nature, size, location of the project and its importance to the country, region</li> <li>▪ Scope of the study – details of regulatory scoping carried out (As per the ToR for EIA Studies)</li> </ul>
2.	Project Description	<p>Condensed description of those aspects of the project (based on project feasibility study), likely to cause environmental effects. Details should be provided to give clear picture of the following:</p> <ul style="list-style-type: none"> <li>▪ Type of project</li> <li>▪ Need for the project</li> <li>▪ Location (maps showing general location, specific location, project boundary &amp; project site layout)</li> <li>▪ Size or magnitude of operation (incl. Associated activities required by or for the project)</li> <li>▪ Proposed schedule for approval and implementation</li> <li>▪ Technology and process description</li> <li>▪ Project description including drawings showing project layout, components of project <i>etc.</i> Schematic representations of the feasibility drawings which give information important for EIA purpose</li> <li>▪ Description of mitigation measures incorporated into the project to meet environmental standards, environmental operating conditions, or other EIA requirements (as required by the scope)</li> <li>▪ Assessment of New &amp; untested technology for the risk of technological failure</li> </ul>
3.	Description of the Environment	<ul style="list-style-type: none"> <li>▪ Study area, period, components &amp; methodology</li> <li>▪ Establishment of baseline for VECs, as identified in the scope</li> <li>▪ Base maps of all environmental components</li> </ul>
4.	Anticipated Environmental Impacts & Mitigation Measures	<ul style="list-style-type: none"> <li>▪ Details of investigated environmental impacts due to project location, possible accidents, project design, project construction, regular operations, final decommissioning or rehabilitation of a completed project</li> <li>▪ Measures for minimizing and / or offsetting adverse impacts identified</li> <li>▪ Irreversible and irretrievable commitments of environmental components</li> <li>▪ Assessment of significance of impacts (Criteria for determining significance, assigning significance)</li> </ul>

S.NO	EIA STRUCTURE	CONTENTS
		<ul style="list-style-type: none"> <li>▪ Mitigation measures</li> </ul>
5.	Analysis of Alternatives (Technology & Site)	<ul style="list-style-type: none"> <li>▪ In case, the scoping exercise results in need for alternatives:</li> <li>▪ Description of each alternative</li> <li>▪ Summary of adverse impacts of each alternative</li> <li>▪ Mitigation measures proposed for each alternative and selection of alternative</li> </ul>
6.	Environmental Monitoring Program	<ul style="list-style-type: none"> <li>▪ Technical aspects of monitoring the effectiveness of mitigation measures (incl. measurement methodologies, frequency, location, data analysis, reporting schedules, emergency procedures, detailed budget &amp; procurement schedules)</li> </ul>
7.	Additional Studies	<ul style="list-style-type: none"> <li>▪ Public consultation</li> <li>▪ Risk assessment</li> <li>▪ Social impact assessment, R&amp;R Action Plans</li> </ul>
8.	Project Benefits	<ul style="list-style-type: none"> <li>▪ Improvements in physical infrastructure</li> <li>▪ Improvements in social infrastructure</li> <li>▪ Employment potential –skilled; semi-skilled and unskilled</li> <li>▪ Other tangible benefits</li> </ul>
9.	Environmental Cost Benefit Analysis	<ul style="list-style-type: none"> <li>▪ If recommended at the Scoping stage</li> </ul>
10.	EMP	<ul style="list-style-type: none"> <li>▪ Description of the administrative aspects that ensures proper implementation of mitigative measures and their effectiveness monitored, after approval of the EIA</li> </ul>
11.	Summary & Conclusion (This will constitute the summary of the EIA Report)	<ul style="list-style-type: none"> <li>▪ Overall justification for implementation of the project</li> <li>▪ Explanation of how, adverse effects have been mitigated</li> </ul>
12.	Disclosure of Consultants engaged	<ul style="list-style-type: none"> <li>▪ Names of the Consultants engaged with their brief resume and nature of Consultancy rendered</li> </ul>

#### 4.10 Public Consultation

Public consultation refers to the process by which the concerns of local affected people and others who have plausible stake in the environmental impacts of the project or activity are ascertained.

- Public consultation is not a decision taking process, but is a process to collect views of the people having plausible stake. If the SPCB/Public agency conducting public hearing is not convinced with the plausible stake, then such expressed views need not be considered.
- Public consultation involves two components, one is public hearing, and other one is inviting written responses/objections through Internet/by post, *etc.*, by placing the summary of EIA report on the web site.
- All Category A and Category B1 projects require public hearing except the following:
  - Once environmental clearance is granted to an industrial estates/SEZs/EPZs *etc.*, for a given composition (type and capacity) of industries, then individual units will not require public hearing
  - Expansion of roads and highways, which do not involve any further acquisition of land.



## Operational Aspects of an EIA

- Maintenance dredging provided the dredged material shall be disposed within port limits
  - All building/ construction projects/ area development projects/townships
  - All Category B2 projects
  - All projects concerning national defense and security or involving other strategic considerations as determined by the Central Government
- Public hearing shall be carried out at the site or in its close proximity, district-wise, for ascertaining concerns of local affected people.
  - Project proponent shall make a request through a simple letter to the Member Secretary of the SPCB or UTPCC to arrange public hearing.
  - Project proponent shall enclose with the letter of request, at least 10 hard copies and 10 soft copies of the draft EIA report including the summary EIA report in English and in the official language of the State/local language prepared as per the approved scope of work, to the concerned Authority.
  - Simultaneously, project proponent shall arrange to send, one hard copy and one soft copy, of the above draft EIA report along with the summary EIA report to the following Authorities within whose jurisdiction the project will be located:
    - District magistrate/District Collector/Deputy Commissioner (s)
    - Zilla parishad and municipal corporation or panchayats union
    - District industries office
    - Urban local business (ULBs)/PRIs concerned/development authorities
    - Concerned regional office of the MoEF/SPCB
  - Above mentioned Authorities except regional office of MoEF shall arrange to widely publicize the draft EIA report within their respective jurisdictions requesting the interested persons to send their comments to the concerned regulatory Authorities. They shall also make draft EIA report for inspection electronically or otherwise to the public during normal office hours till the public hearing is over.
  - Concerned regulatory Authority (MoEF/SEIAA/UTEIA) shall display the summary of EIA report on its website and also make full draft EIA report available for reference at a notified place during normal office hours at their head office.
  - SPCB or UTPCC concerned shall also make similar arrangements for giving publicity about the project within the State/UT and make available the summary of draft EIA report for inspection in select offices, public libraries or any other suitable location, *etc.*, They shall also additionally make available a copy of the draft EIA report to the above five authorities/offices as mentioned above.
  - The Member–Secretary of the concerned SPCB or UTPCC shall finalize the date, time and exact venue for the conduct of public hearing within seven days of the date of the receipt of the draft EIA report from the project proponent and advertise the same in one major National Daily and one Regional vernacular Daily/ official State language.
  - A minimum notice period of 30 (thirty) days shall be provided to the public for furnishing their responses.
  - No postponement of the date, time, venue of the public hearing shall be undertaken, unless some untoward emergency situation occurs. Only in case of emergencies and up on the recommendation of the concerned District Magistrate/ District Collector/ Deputy Commissioner, the postponement shall be notified to the public through the same National and Regional vernacular dailies and also prominently displayed at all the identified offices by the concerned SPCB or UTPCC

- In the above exceptional circumstances fresh date, time and venue for the public consultation shall be decided by the Member–Secretary of the concerned SPCB or UTPCC only in consultation with the District Magistrate/District Collector/Deputy Commissioner and notified afresh as per the procedure.
- The District Magistrate/District Collector/Deputy Commissioner or his or her representative not below the rank of an Additional District Magistrate assisted by a representative of SPCB or UTPCC, shall supervise and preside over the entire public hearing process.
- The SPCB or UTPCC shall arrange to video film the entire proceedings. A copy of the videotape or a CD shall be enclosed with the public hearing proceedings while forwarding it to the Regulatory Authority concerned.
- The attendance of all those who are present at the venue shall be noted and annexed with the final proceedings
- There shall be no quorum required for attendance for starting the proceedings
- Person present at the venue shall be granted the opportunity to seek information or clarifications on the project from the proponent. The summary of the public hearing proceedings accurately reflecting all the views and concerns expressed shall be recorded by the representative of the SPCB or UTPCC and read over to the audience at the end of the proceedings explaining the contents in the local/vernacular language and the agreed minutes shall be signed by the District Magistrate/District Collector/Deputy Commissioner or his or her representative on the same day and forwarded to the SPCB/UTPCC concerned.
- A statement of the issues raised by the public and the comments of the proponent shall also be prepared in the local language or the official State language, as the case may be and in English and annexed to the proceedings.
- The proceedings of the public hearing shall be conspicuously displayed at the office of the Panchayats within whose jurisdiction the project is located, office of the concerned Zilla Parishad, District Magistrate/District Collector/Deputy Commissioner, and the SPCB or UTPCC. The SPCB or UTPCC shall also display the proceedings on its website for general information. Comments, if any, on the proceedings, may be sent directly to the concerned regulatory authorities and the Applicant concerned.
- The public hearing shall be completed within a period of 45 (forty five) days from date of receipt of the request letter from the Applicant. Therefore the SPCB or UTPCC concerned shall send public hearing proceedings to the concerned regulatory authority within eight (8) days of the completion of the public hearing. Simultaneously, a copy will also be provided to the project proponent. The proponent may also directly forward a copy of the approved public hearing proceedings to the regulatory authority concerned along with the final EIA report or supplementary report to the draft EIA report prepared after the public hearing and public consultations incorporating the concerns expressed in the public hearing along with action plan and financial allocation, item-wise, to address those concerns.
- Upon receipt of the same, the Authority will place executive summary of the report on the website to invite responses from other concerned persons having a plausible stake in the environmental aspects of the project or activity.
- If SPCB/UTPCC is unable to conduct public hearing in the prescribed time, the Central Government in case of Category A projects and State Government or UT administration in case of Category B projects at the request of the SEIAA may engage

a public agency for conducting the public hearing process within a further period of 45 days. The respective governments shall pay the appropriate fee to the public agency for conducting public hearing.

- A public agency means a non-profit making institution/ body such as technical/academic institutions, government bodies not subordinate to the concerned Authority.
- If SPCB/Public Agency authorized for conducting public hearing informs the Authority, stating that it is not possible to conduct the public hearing in a manner, which will enable the views of the concerned local persons to be freely expressed, then Authority may consider such report to take a decision that in such particular case, public consultation may not have the component of public hearing.
- Often restricting the public hearing to the specific district may not serve the entire purpose, therefore, NGOs who are local and registered under the Societies Act in the adjacent districts may also be allowed to participate in public hearing, if they so desire.
- Confidential information including non-disclosable or legally privileged information involving intellectual property right, source specified in the application shall not be placed on the website.
- The Authority shall make available on a written request from any concerned person the draft EIA report for inspection at a notified place during normal office hours till the date of the public hearing.
- While mandatory requirements will have to be adhered to, utmost attention shall be given to the issues raised in the public hearing for determining the modifications needed in the project proposal and EMP to address such issues.
- Final EIA report after making needed amendments, as aforesaid, shall be submitted by the applicant to the concerned Authority for prior environmental clearance. Alternatively, a supplementary report to draft EIA and EMP addressing all concerns expressed during the public consultation may be submitted.

#### **4.11 Appraisal**

Appraisal means the detailed scrutiny by the EAC or SEAC of the application and the other documents like the final EIA report, outcome of the public consultation including public hearing proceedings submitted by the applicant for grant of environmental clearance.

- The appraisal shall be made by EAC to the Central Government or SEAC to SEIAA.
- Project proponent either personally or through consultant can make a presentation to EAC/SEAC for the purpose of appraising the features of the project proposal and also to clarify the issues raised by the members of the EAC/SEAC.
- On completion of these proceedings, concerned EAC/SEAC shall make categorical recommendations to the respective Authority, either for grant of prior environmental clearance on stipulated terms & conditions, if any, or rejection of the application with reasons.
- In case EAC/SEAC needs to visit the site or obtain further information before being able to make categorical recommendations, EAC/SEAC may inform the project proponent accordingly. In such an event, it should be ensured that the process of

environmental clearance is not unduly delayed to go beyond the prescribed timeframe.

- Upon the scrutiny of the final report, if EAC/SEAC opines that ToR for EIA studies finalized at the scoping stage are not covered by the proponent, then the project proponent may be asked to provide such information. If such information is declined by the project proponent or is unlikely to be provided early enough so as to complete the environmental appraisal within prescribed time of 60 days, the EAC/SEAC may recommend for rejection of the proposal with the same reason.
- Appraisal shall be strictly in terms of ToR for EIA studies finalized at the scoping stage and the concerns expressed during public consultation.
- This process of appraisal shall be completed within 60 days from the receipt of the updated EIA and EMP reports, after completing public consultation.
- The EIA report will be typically examined for following:
  - Project site description supported by topographic maps & photographs – detailed description of topography, land use and activities at the proposed project site and its surroundings (buffer zone) supported by photographic evidence.
  - Clarity in description of drainage pattern, location of eco sensitive areas, vegetation characteristics, wildlife status - highlighting significant environmental attributes such as feeding, breeding and nesting grounds of wildlife species, migratory corridor, wetland, erosion and neighboring issues.
  - Description of the project site – how well the interfaces between the project related activities and the environment have been identified for the entire project cycle *i.e.* construction, operation and decommissioning at the end of the project life.
  - If it is envisaged that the project is to be closed after a specified period in case of mining projects, the interface at the closure stage also needs to be described.
  - How complete and authentic are the baseline data pertaining to flora and fauna and socio-economic aspects?
  - Citing of proper references, with regard to the source(s) of baseline data as well as the name of the investigators/investigating agency responsible for collecting the primary data.
  - How consistent are the various values of environmental parameters with respect to each other?
  - Is a reasonable assessment of the environmental and social impact made for the identified environmental issues including project affected people?
  - To what extent the proposed environmental plan will mitigate the environmental impact and at what estimated cost, shown separately for construction, operation and closure stages and also separately in terms of capital and recurring expenses along with details of agencies that will be responsible for the implementation of environmental plan/ conservation plan.

- How well the concerns expressed/highlighted during public hearing have been addressed and incorporated in the EMP giving item wise financial provisions and commitments (in quantified terms)?
- How far the proposed environmental monitoring plan will effectively evaluate the performance of EMP? Are details for environmental monitoring plan provided in the same manner as the EMP?
- Identification of hazard and quantification of risk assessment and whether appropriate mitigation plan has been included in the EMP?
- Does the proposal include a well formulated time bound green belt development plan for mitigating environmental problems such as fugitive emission of dust, gaseous pollutants, noise, odour, *etc.*
- Does EIA makes a serious attempt to guide the project proponent for minimizing the requirement of natural resources including land, water energy and other non renewable resources?
- How well has the EIA statement been organized and presented so that the issues, their impact and environmental management strategies emerge clearly from it and how well organized was the power point presentation made before the expert committee?
- Is the information presented in the EIA adequately and appropriately supported by maps, imageries and photographs highlighting site features and environmental attributes?

#### **4.12 Decision-making**

The Chairperson reads the sense of the Committee and finalizes the draft minutes of the meeting, which are circulated by the Secretary to all expert members invited to the meeting. Based on the response from the members, the minutes are finalized and signed by the Chairperson. This process for finalization of the minutes should be so organized that the time prescribed for various stages is not exceeded.

#### **Approval / Rejection / Reconsideration**

- The Authority shall consider the recommendations of concerned appraisal Committee and convey its decision within 45 days of the receipt of recommendations.
- If the Authority disagrees with the recommendations of the Appraisal Committee, then reasons shall be communicated to concerned Appraisal Committee and applicant within 45 days from the receipt of the recommendations. The Appraisal Committee concerned shall consider the observations of the Authority and furnish its views on the observations within further period of 60 days. The Authority shall take a decision within the next 30 days based on the views of appraisal Committee.
- If the decision of the Authority is not conveyed within the time, then the proponent may proceed as if the environmental clearance sought has been granted or denied by the regulatory authority in terms of the final recommendation of the concerned appraisal Committee. For this purpose, the decision of the Appraisal Committee will be a public document, once the period specified above for taking the decision by the Authority is over.

- In case of Category B projects, application shall be received by the Member–Secretary of the SEIAA and clearance shall also be issued by the same SEIAA.

#### **If Approved**

- The concerned authority (MoEF/SEIAA) will issue the environmental clearance for the project.
- The project proponent should make sure that the award of environmental clearance is properly publicized in at least two local newspapers of the district or state where the proposed project is located. For instance, the executive summary of the environmental clearance may be published in the newspaper along with the information about the location (website/office where it is displayed for public) where the detailed environmental clearance is made available. The MoEF and the SEIAA/UTEIAA, as the case may be, shall also place the environmental clearance in the public domain on Government Portal. Further copies of the environmental clearance shall be endorsed to the Heads of local bodies, Panchayats and Municipal bodies in addition to the relevant offices of the Government
- The environmental clearance will be valid from the start date to actual commencement of the production of the developmental activity.

### **4.13 Post-clearance Monitoring Protocol**

The MoEF, Government of India will monitor and take appropriate action under the EP Act, 1986.

- In respect of Category A projects, it shall be mandatory for the project proponent to make public the environmental clearance granted for their project along with the environmental conditions and safeguards at their cost by advertising it at least in two local newspapers of the district or State where the project is located and in addition, this shall also be displayed in the project proponents website permanently.
- In respect of Category B projects, irrespective of its clearance by MoEF/SEIAA, the project proponent shall prominently advertise in the newspapers indicating that the project has been accorded environment clearance and the details of MoEF website where it is displayed.
- The MoEF and the SEIAAs/UTEIAAs, as the case may be, shall also place the environmental clearance in the public domain on Government Portal.
- Copies of environmental clearance shall be submitted by the project proponents to the Heads of the local bodies, Panchayats and Municipal bodies in addition to the relevant offices of the Government who in turn have to display the same for 30 days from the date of receipt.

The project proponent must submit half-yearly compliance reports in respect of the stipulated prior environmental clearance terms and conditions in hard and soft copies to the regulatory authority concerned, on 1st June and 1st December of each calendar year.

All such compliance reports submitted by the project management shall be public documents. Copies of the same shall be given to any person on application to the concerned regulatory authority. Such latest compliance report shall also be displayed on the web site of the concerned regulatory Authority.

---

**Operational Aspects of an EIA**

The SPCB shall incorporate EIA clearance conditions into consent conditions in respect of Category A and Category B projects and in parallel shall monitor and enforce the same.

## 5.

# STAKEHOLDERS' ROLES AND RESPONSIBILITIES

Prior environmental clearance process involves many stakeholders *i.e.*, Central Government, State Government, SEIAA, EAC at the National Level, SEAC, Public Agency, SPCB, the project proponent, and the public.

- Roles and responsibilities of the organizations involved in different stages of prior environmental clearance are listed in Table 5-1.
- Organization-specific functions are listed in Table 5-2.

In this Chapter, constitution, composition, functions, *etc.*, of the Authorities and the Committees are discussed in detail.

**Table 5-1: Roles and Responsibilities of Stakeholders Involved in Prior Environmental Clearance**

Stage	MoEF/SEIAA	EAC/SEAC	Project Proponent	EIA Consultant	SPCB/ Public Agency	Public And Interest Group
<b>Screening</b>	Receives application and takes advice of EAC/SEAC	Advises the MoEF/SEIAA	Submits application (Form 1) and provides necessary information	Advises and assists the proponent by providing technical information		
<b>Scoping</b>	Approves the ToR, communicates the same to the project proponent and places the same in the website	Reviews the ToR, visits the proposed site, if required and recommends the ToR to the MoEF/SEIAA	Submits the draft ToR to MoEF/SEIAA and facilitates the visit of the EAC/SEAC members to the project site	Prepares ToR		
<b>EIA Report &amp; Public Hearing</b>	Reviews and forwards copies of the EIA report to SPCB /public agency for conducting public		Submits detailed EIA report as per the finalized ToR  Facilitates the public hearing by arranging presentation on the project,	Prepares the EIA report  Presents and appraises the likely impacts and pollution control measures proposed in	Reviews EIA report and conducts public hearing in the manner prescribe	Participates in public hearings and offers comments and observations.  Comments can be sent



### Stakeholders' Roles and Responsibilities

Stage	MoEF/SEIAA	EAC/SEAC	Project Proponent	EIA Consultant	SPCB/ Public Agency	Public And Interest Group
	<p>hearing</p> <p>Places the summary of EIA report in the website</p> <p>Conveys objections to the project proponent for update, if any.</p>		EIA and EMP – takes note of objections and updates the EMP accordingly	the public hearing	<p>d</p> <p>Submits proceedings and views of SPCB, to the Authority and the project proponent as well</p>	directly to SEIAA through Internet in response to the summary placed in the website
<b>Appraisal and Clearance</b>	<p>Receives updated EIA</p> <p>Takes advice of EAC/SEAC, approves EIA and attaches the terms and conditions</p>	Critically examines the reports, presentation of the proponent and appraises MoEF/SEIAA (recommendations are forwarded to MoEF/SEIAA)	<p>Submits updated EIA, EMP reports to MoEF/SEIAA</p> <p>Presents the overall EIA and EMP including public concerns to EAC/SEAC</p>	Provides technical advise to the project proponent and if necessary presents the proposed measures for mitigation of likely impacts (terms and conditions of clearance)		
<b>Post-clearance Monitoring</b>			Implements environmental protection measures prescribed and submits periodic monitoring results	Conducts periodic monitoring	Incorporates the clearance conditions into appropriate consent conditions and ensures implementation	

**Table 5-2: Organization-Specific Functions**

ORGANIZATION	FUNCTIONS
<b>Central Government</b>	<ul style="list-style-type: none"> <li>▪ Constitutes the EAC</li> <li>▪ Considering recommendations of the State Government, constitutes the SEIAA &amp; SEAC</li> <li>▪ Receives application from the project proponent in case of Category A projects or Category B projects attracting general condition</li> <li>▪ Communicates the ToR finalized by the EAC to the project proponent.</li> <li>▪ Receives EIA report from the project proponent and soft copy of summary of the report for placing in the website</li> <li>▪ Summary of EIA report will be placed in website. Forwards the received responses to the project proponent</li> <li>▪ Engages other public agency for conducting public hearings in cases where the SPCB does not respond within time</li> <li>▪ Receives updated EIA report from project proponent incorporating the considerations from the proceedings of public hearing and responses received through other media</li> <li>▪ Forwards updated EIA report to the EAC for appraisal</li> <li>▪ Either accepts the recommendations of EAC or asks for reconsideration of specific issues for review by the EAC.</li> <li>▪ Takes the final decision – acceptance/ rejection – of the project proposal and communicates the same to the project proponent</li> </ul>
<b>State Government</b>	<ul style="list-style-type: none"> <li>▪ Identifies experts as per the composition specified in the Notification and subsequent guidelines to recommend to the Central Government.</li> <li>▪ Extends funding support to fulfill the functions of SEIAA/SEAC</li> <li>▪ Engages other public agency for conducting public hearings in cases where the SPCB does not respond within time</li> <li>▪ State Governments will suitably pay the public agency for conducting such activity</li> </ul>
<b>EAC</b>	<ul style="list-style-type: none"> <li>▪ Reviews Form 1 and its attachments</li> <li>▪ Visits site(s), if necessary</li> <li>▪ Finalizes ToR and recommends to the Central Government, which in turn communicates the finalized ToR to the project proponent, if not exempted by the Notification</li> <li>▪ Reviews EIA report, proceedings and appraises their views to the Central government</li> <li>▪ If the Central Government has any specific views, then the EAC reviews again for appraisal</li> </ul>
<b>SEIAA</b>	<ul style="list-style-type: none"> <li>▪ Receives application from the project proponent</li> <li>▪ Considers SEAC's views for finalization of ToR</li> <li>▪ Communicates the finalized ToR to the project proponent</li> <li>▪ Receives EIA report from project proponent</li> <li>▪ Uploads the summary of EIA report in the website in cases of Category B projects</li> <li>▪ Forwards the responses received to the project proponent</li> <li>▪ Receives updated EIA report from project proponent incorporating the considerations from the proceedings of public hearing and responses received through other media</li> <li>▪ Forwards updated EIA report to SEAC for appraisal</li> <li>▪ Either accepts the recommendations of SEAC or asks for reconsideration of specific issues for review by SEAC.</li> <li>▪ Takes the final decision and communicates the same to the project proponent</li> </ul>
<b>SEAC</b>	<ul style="list-style-type: none"> <li>▪ Reviews Form 1</li> <li>▪ If necessary visits, site(s) for finalizing the ToR</li> </ul>

ORGANIZATION	FUNCTIONS
	<ul style="list-style-type: none"> <li>▪ Reviews updated EIA - EMP report and</li> <li>▪ Appraises the SEIAA</li> </ul>
<b>SPCB</b>	<ul style="list-style-type: none"> <li>▪ Receives request from project proponent and conducts public hearing in the manner prescribed.</li> <li>▪ Conveys proceedings to concerned authority and project proponent</li> </ul>
<b>Public Agency</b>	<ul style="list-style-type: none"> <li>▪ Receives request from the respective Governments to conduct public hearing</li> <li>▪ Conducts public hearing in the manner prescribed.</li> <li>▪ Conveys proceedings to the concerned Authority/EAC /Project proponent</li> </ul>

## 5.1 SEIAA

- SEIAA is constituted by the MoEF to take final decision regarding the acceptance/rejection of prior environmental clearance to the project proposal for all Category 'B' projects.
- The state government may decide whether to house them at the Department of Environment or at any other Board for effective operational support.
- State Governments can decide whether the positions are permanent or part-time. The Central Government (MoEF) continues to follow the model of paying fee (TA/DA, accommodation, sitting fee) to the Chairperson and the members of EAC. As such, the State Government is to fund SEIAA & SEAC and decide the appropriate institutional support for them.

### A. Constitution

- SEIAA is constituted by the Central Government comprising of three members including a Chairperson and Member–Secretary to be nominated by the State Government or UT Administration concerned.
- The Central Government will notify as and when the nominations (in order) are received from the State Governments, within 30 days from the date of receipt.
- The Chairperson and the non-official member shall have a fixed term of three years, from the date of Notification by the Central Government constituting the Authority.

The form used by the State Governments to submit nominations for Notification by the Central Government is provided in **Annexure XI**.

### B. Composition

- Chairperson shall be an expert in the EIA process
- Member–Secretary shall be a serving officer of the concerned State Government/UT Administration familiar with the environmental laws.
- Member–Secretary may be of a level equivalent to the Director, Dept. of Environment or above – a full time member.
- All the members including the Chairperson shall be the experts as per the criteria set in the Notification.
- The Government servants can only serve as the Member–Secretary to SEIAA and the Secretary to SEAC. All other members including Chairperson of the SEIAA and SEAC shall not be comprised of serving Government Officers; industry representatives; and the activists.

### Stakeholders' Roles and Responsibilities

- Serving faculty (academicians) is eligible for the membership in the Authority and/or the Committees, if they fulfill the criteria given in Appendix VI to the Notification.
- This is to clarify that the serving Government officers shall not be nominated as professional/expert member of SEIAA/SEAC/EAC.
- Professionals/Experts in the SEIAA and SEAC shall be different.

Summary regarding the eligibility criteria for Chairperson and Members of the SEIAA is given in Table 5-3.

### C. Decision-making process

- The decision of the Authority shall be arrived through consensus.
- If there is no consensus, the Authority may either ask SEAC for reconsideration or may reject the approval.
- All decisions of the SEIAA shall be taken in a meeting and shall ordinarily be unanimous. In case a decision is taken by majority, details of views, for and against the decision, shall be clearly recorded in minutes of meeting and a copy thereof shall be sent to MoEF.

**Table 5-3: SEIAA: Eligibility Criteria for Chairperson / Members / Secretary**

S. No.	Attribute	Requirement			
		Members	Member–Secretary	Chairperson	
1	Professional qualification as per the Notification	Compulsory	Compulsory	Compulsory	
2	Experience (Fulfilling any one of a, b, c)	a	Professional Qualification + 15 years of experience in one of the expertise area mentioned in the Appendix VI	Professional Qualification + 15 years of experience in one of the expertise area mentioned in the Appendix VI	Professional Qualification + 15 years of experience in one of the expertise area mentioned in the Appendix VI
		b	Professional Qualification +PhD+10 years of experience in one of the expertise area mentioned in Appendix VI	Professional Qualification +PhD+10 years of experience in one of the expertise area mentioned in the Appendix VI	Professional Qualification +PhD+10 years of experience in one of the expertise area mentioned in the Appendix VI
		c	Professional Qualification +10 years of experience in one of the expertise area mentioned in the	Professional Qualification +10 years of experience in one of the expertise area mentioned in the	-----

### Stakeholders' Roles and Responsibilities

S. No.	Attribute	Requirement		
		Members	Member–Secretary	Chairperson
		Appendix VI + 5 years interface with environmental issues, problems and their management	Appendix VI + 5 years interface with environmental issues, problems and their management	
3	Test of independence (conflict of interest) and minimum grade of the Secretary of the Authority	<p>Shall not be a serving government officer</p> <p>Shall not be a person engaged in industry and their associations</p> <p>Shall not be a person associated with environmental activism</p>	Only serving officer from the State Government (DoE) familiar with environmental laws not below the level of Director	<p>Shall not be a serving government officer</p> <p>Shall not be a person engaged in industry and their associations</p> <p>Shall not be a person associated with environmental activism</p>
4	Age	Below 67 years at the time of Notification of the Authority	As per State Government Service Rules	Below 72 Years at the time of the Notification of the Authority
5	Other memberships in Central / State Expert Appraisal Committee	Shall not be a member in any SEIAA/EAC/SEAC	Shall not be a member in any SEIAA/EAC/SEAC	Shall not be a member in any SEIAA/EAC/SEAC
6	Tenure of earlier appointment (continuous)	Only one term before this in continuity is permitted	Not applicable	Only one term before this in continuity is permitted
7	Eminent environmental expertise with understanding on environmental aspects and impacts	Desirable	Desirable	Compulsory
8	Expertise in the environmental clearance process	Desirable	Desirable	Compulsory

Note:

1. *A member after continuous membership in two terms (six years) shall not be considered for further continuation. His/her nomination may be considered after a gap of one term (three years), if other criteria meet.*
2. *Chairperson/Member( once notified may not be removed prior to the tenure of three years without cause and proper enquiry.*

## 5.2 EAC and SEAC

EAC and SEAC are independent Committees to review each developmental activity and offer its recommendations for consideration of the Central Government and SEIAA respectively.

### A. Constitution

- EAC and SEAC shall be constituted by the Central Government comprising a maximum of 15 members including a Chairperson and Secretary. In case of SEAC, the State Government or UT Administration is required to nominate the professionals/experts for consideration and Notification by the Central Government.
- The Central Government will notify as and when the nominations (in order) are received from the State Governments, within 30 days from the date of receipt.
- The Chairperson and the non-official member shall have a fixed term of three years, from the date of Notification by the Central Government.
- The Chairperson shall be an eminent environmental expert with understanding on environmental aspects and environmental impacts. The Secretary of the SEAC shall be a State Government officer, not below the level of a Director/Chief Engineer.
- The members of the SEAC need not be from the same State/UT.
- In case the State Governments/ UTs so desire, the MoEF can form regional EAC to serve the concerned States/UTs.
- State Governments may decide to their convenience to house SEAC at the Department of Environment or at SPCB or at any other department, to extend support to the SEAC activities.

### B. Composition

- Composition of EAC/SEAC as per the Notification is given in **Annexure XII**.
- Secretary to EAC/SEAC may invite a maximum of two professionals/experts with the prior approval of the Chairperson, if desired, for taking the advisory inputs for appraisal. In such case, the invited experts will not take part in the decision making process.
- The Secretary of each EAC/SEAC preferably be an officer of the level equivalent to or above the level of Director, MoEF, GoI.

### C. Decision-making

The EAC and SEAC shall function on the principle of collective responsibility. The Chairperson shall endeavor to reach a consensus in each case, and if consensus cannot be reached, the view of the majority shall prevail.

## D. Operational issues

- Secretary may deal with all correspondence, formulate agenda and prepare agenda notes. Chairperson and other members may act only for the meetings.
- Chairperson of EAC/SEAC shall be one among the core group having considerable professional experience with proven credentials.
- EAC/SEAC shall meet at least once every month or more frequently, if so needed, to review project proposals and to offer recommendations for the consideration of the Authority.
- EAC/SEAC members may inspect the site at various stages *i.e.* during screening, scoping and appraisal, as per the need felt and decided by the Chairperson of the Committee.
- The respective Governments through the Secretary of the Committee may pay/reimburse the participation expenses, honorarium *etc.*, to the Chairperson and members.

### i. Tenure of EAC/SEIAA/SEAC

The tenure of Authority/Committee(s) shall be for a fixed period of three years. At the end of the three years period, the Authority and the committees need to be re-constituted. However, staggered appointment dates may be adopted to maintain continuity of members at a given point of time.

### ii. Qualifying criteria for nomination of a member to EAC/SEIAA/SEAC

While recommending nominations and while notifying the members of the Authority and Expert Committees, it shall be ensured that all the members meet the following three criteria:

- Professional qualification
- Relevant experience/Experience interfacing with environmental management
- Absence of conflict of interest

These are elaborated subsequently.

#### a) Professional qualification

The person should have at least

- 5 years of formal University training in the concerned discipline leading to a MA/MSc Degree, or
- In case of Engineering/Technology/Architecture disciplines, 4 years formal training in a professional training course together with prescribed practical training in the field leading to a B.Tech/B.E./B.Arch. Degree, or
- Other professional degree (*e.g.* Law) involving a total of 5 years of formal University training and prescribed practical training, or
- Prescribed apprenticeship/article ship and pass examinations conducted by the concerned professional association (*e.g.* MBA/IAS/IFS). In selecting the individual professionals, experience gained by them in their respective fields will be taken note of.

#### b) Relevant experience

## Stakeholders' Roles and Responsibilities

- Experience shall be related to professional qualification acquired by the person and be related to one or more of the expertise mentioned for the expert members. Such experience should be a minimum of 15 years.
- When the experience mentioned in the foregoing sub-paragraph interfaces with environmental issues, problems and their management, the requirement for the length of the experience can be reduced to a minimum of 10 years.

### c) Absence of conflict of interest

For the deliberations of the EAC/SEAC to be independent and unbiased, all possibilities of potential conflict of interests have to be eliminated. Therefore, serving government officers; persons engaged in industry and their associations; persons associated with the formulation of development projects requiring environmental clearance, and persons associated with environmental activism shall not be considered for membership of SEIAA/ SEAC/ EAC.

### iii. Age

Below 70 years for the members and below 72 years for the Chairperson of the SEIAA/SEAC/EAC. The applicability of the age is at the time of the Notification of the SEIAA/SEAC/EAC by the Central Government.

Summary regarding the eligibility criteria for Chairperson and Members of the EAC/SEAC are given in Table 5-4.

**Table 5-4: EAC/SEAC: Eligibility Criteria for Chairperson / Members / Secretary**

S. No.	Attribute		Requirement		
			Expert members	Secretary	Chairperson
1	Professional qualification as per the Notification		Compulsory	Compulsory	Compulsory
2	Experience (Fulfilling any one of a, b, c)	a	Professional Qualification + 15 years of experience in one of the expertise area mentioned in the Appendix VI	Professional Qualification + 15 years of experience in one of the expertise area mentioned in the Appendix VI	Professional Qualification + 15 years of experience in one of the expertise area mentioned in the Appendix VI
		b	Professional Qualification +PhD+10 years of experience in one of the expertise area mentioned in the Appendix VI	Professional Qualification +PhD+10 years of experience in one of the expertise area mentioned in the Appendix VI	Professional Qualification +PhD+10 years of experience in one of the expertise area mentioned in Appendix VI



### Stakeholders' Roles and Responsibilities

S. No.	Attribute	Requirement		
		Expert members	Secretary	Chairperson
	c	Professional Qualification +10 years of experience in one of the expertise area mentioned in the Appendix VI + 5 years interface with environmental issues, problems and their management	Professional Qualification +10 years of experience in one of the expertise area mentioned in the Appendix VI + 5 years interface with environmental issues, problems and their management	-----
3	Test of independence (conflict of interest) and minimum grade of the Secretary of the Committees	<p>Shall not be a serving government officer</p> <p>Shall not be a person engaged in industry and their associations</p> <p>Shall not be a person associated with environmental activism</p>	<p>In case of EAC, not less than a Director from the MoEF, Government of India</p> <p>In case of SEAC, not below the level of Director/Chief Engineer from the State Government (DoE)</p>	<p>Shall not be a serving government officer</p> <p>Shall not be a person engaged in industry and their associations</p> <p>Shall not be a person associated with environmental activism</p>
4	Age	Below 67 years at the time of Notification of the Committee	As per state Government Service Rules	Below 72 Years at the time of the Notification of the Committee
5	Membership in Central/State Expert Appraisal committee	Only one other than this nomination is permitted	Shall not be a member in other SEIAA/EAC/SEAC	Shall not be a member in any other SEIAA/EAC/SEAC
6	Tenure of earlier appointment (continuous)	Only one term before this in continuity is permitted	Not applicable	Only one term before this in continuity is permitted
7	Eminent environmental expertise with understanding on environmental aspects and impacts	Desirable	Not applicable	Compulsory

Note:

*1. A member after continuous membership in two terms (six years) shall not be considered for further continuation. His/her nomination may be reconsidered after a gap of one term (three years), if other criteria meet.*

2. *Chairperson/Member once notified may not be removed prior to the tenure of 3 years with out cause and proper enquiry. A member after continuous membership in two terms (6 years) shall not be considered for further continuation. The same profile may be considered for nomination after a gap of three years, i.e., one term, if other criteria are meeting.*

### **E. Other conditions**

- An expert member of one State/UT, can have at the most another State/UT Committee membership (core or sectoral expert member), but in no case more than two Committees at a given point of time.
- An expert member of a Committee shall not have membership continuously in the same committee for more than two terms, *i.e.* six years. They can be nominated after a gap of three years, *i.e.*, one term. When a member of Committee has been associated with any development project, which comes for environmental clearance, he/she may not participate in the deliberations and the decisions in respect to that particular project.
- At least four members shall be present in each meeting to fulfill the quorum.
- If a member does not consecutively attend six meetings, without prior intimation to the Committee his/her membership may be terminated by the Notifying Authority. Prior information for absence due to academic pursuits, career development and national/state-endorsed programmes may be considered as genuine grounds for retention of membership.

---

**ANNEXURE I**  
**Manufacturing Process of Rectified Spirit Based on Molasses**  
**(Biostil Process)**

---

# **Manufacturing process of Rectified Spirit Based on Molasses (Biostil Process)**

## **1.1 Fermentation**

Molasses, diluted with water to the desired concentration is metered continuously into a bigger fermenter where maximum reaction for conversion will take place. Additives like urea (if required in the form of pellets or prills) and defoaming oil are also introduced in the fermenter as required. There is an automatic foam level sensing and dosing system for de-foaming oil.

Every Kilogram of alcohol produced, generates about 290 Kcal of heat. This excess heat is removed by continuous circulation of the fermenting wash through an external plate heat exchanger called the Fermenter Cooler. The fermenter temperature is always maintained between 32 and 35 deg. C, the range optimum for efficient fermentation.

The yeast for the fermentation is initially (i.e. during start-up of the plant) developed in the Propagation Section described further on. Once propagated, a viable cell population of about 300-500 million cells/ml is maintained by yeast recycling and continuous aeration of the fermenter. Fluctuations in the yeast count of  $\pm 20\%$  have little effect on the overall fermenter productivity. Yeast cell vitality which is usually above 70% may, in times of stress (such as prolonged shut-downs) drop to 50 % without affecting the fermentation.

Fermented wash passes through a series of hydro-cyclones (one to three or more in number depending on plant capacity), which remove grit, iron filings and similar heavy particulate matter. This rejected material along with some wash is taken through a Decanter Centrifuge, where the concentrated sludge of 25 – 30 % v/v is generated which can be disposed on the sludge drying beds or can be added in the composting. The clarified portion of the wash is taken back to wash holding tank for feeding the distillation section for alcohol recovery. The overflow from the first hydro-cyclone is taken to yeast separators for separation of the yeast & the separated yeast is taken back to the fermenter.

The bottom portion of the hydrocyclone facilitates the removal of heavy particulate matter. The hydro-cyclone protect the separator from erosion damage by removing grit and similar hard particles.

### **1.1.1 Yeast recycling**

The yeast in the fermented wash is removed as 40 to 45 % v/v slurry, and is returned to the fermenter. This feature, unique to Continuous Fermentation Process, ensures that a high yeast cell concentration is achieved and maintained in the fermenter. By re-circulating grown, active yeast, sugar that would have otherwise been consumed in yeast growth, is made available for ethanol production, ensuring high process efficiency.

### **1.1.2 Weak wash recycling**

The recycling of weak wash helps maintain the desired level of dissolved solids in the fermenter, so that an adequately high osmotic pressure is achieved.

Osmotic pressure and the concentration of alcohol in the fermenter, together keep off infection and minimize sugar losses. Weak wash recycling also reduces the quantity of effluent spent wash and reduces the process water requirement of the plant. Normally this is taken from the 5th plate of the Analyzer Column.

Spent wash is the wash from which all alcohol has been removed, this emerges from the bottom of the wash column. Some of the heat is recovered to preheat fermented wash entering the de-gassing column. Spent wash is also passed through a forced circulation re-boiler to generate vapours. This concentrates the effluent and reduces the volume further. The Spent Wash volume generated can be in the range of 6-8 Ltrs/ Ltr of Alcohol produced depending on the FS/ NFS ratio of the feed Molasses.

### **1.1.3 Propagation**

The propagation section is a feeder unit to the fermenter. Schizosaccharomyces pombe Yeast is used. This is grown in 3 stages. The first two stages are designed for aseptic growth. Propagation vessel III, develops the inoculum using pasteurized molasses solution as the medium. This vessel has a dual function. During propagation, it serves for inoculum build-up. When the fermenter enters the continuous production mode, Propagation Vessel III is used as an intermediate wash tank. Propagation is carried out only to start up the process initially or after very long shut-downs during which the fermenter is emptied.

## **1.2 Distillation section**

Distillation section is designed with multi pressure vacuum distillation technique to produce Rectified spirit. The system designed is integrated for minimum steam consumption while producing Rectified Spirit directly from the fermented wash. The system comprises of Wash-cum-Degassifier Column with Rectifier Column, & Heads Column.

The clarified wash after heating in wash heater by over head vapours from wash column is further heated in spent wash heater is fed to degassing section of column. The vapours from wash column are partially condensed in a beer heater condenser for recovery of heat & non-condensed vapours are condensed in the final condenser. The beer/ wash column is operated under vacuum and designed with sieve trays. The design of wash column enables operation of the column continuously for longer durations ( minimum 180 days without opening for cleaning ). The energy to beer column is provided by re-boiler located at the bottom of column and heated by over head vapours from rectifier column.

The raw spirit approx. 40% w/w is sent to intermediate raw spirit tank. Raw Spirit is then fed to stripper rectifier column for removing high volatile impurities. Fusel oils are tapped from appropriate trays and separated in fusel oil decanter after cooling in fusel oil cooler. The rectifier column is designed to operate under pressure with Sieve

tray construction and heated by steam through re-boiler located at the bottom of column.

The alcohol from rectifier column is then taken to product cooler to cool it down to 350 C. The Impure cut from the top of the Degassifying section is taken to degass condenser & condensed against water. The condensate is then fed to heads / aldehyde column where it is diluted with water for further rectification in the column & finally the impure cut is removed from the top vent condensers of the heads column.

### **1.3 Falling film spent wash evaporator**

#### **1.3.1 Process Description**

##### **1.3.1.1 Effect Evaporator using vapour from Analyser column**

###### **Feed Inlet – E1 – E2 – E3 –Outlet**

Since the evaporator is integrated with distillery plant, vapour from Analyser column is used as heating media in evaporator. As a result, the temperature profile in evaporator is lower. Outlet Product Concentration is also lower, just about 38.16%. This will considerably reduce the offline CIP frequency and so the downtime of evaporator.

##### **1.3.1.2 Process description for tubular evaporator**

We propose a 3 effect evaporator system for the spent wash designed for concentration from 19.4 % to 38.16 %. All the Effects are falling film type with vapour separators. The feed will be introduced in Effect 1. Subsequently it will be transferred to Effect 2 and then to Effect 3 & finally to battery limit, by means of transfer cum recycle pumps. Final concentration is achieved in E3. Level control loops are provided for all effects to ensure trouble free operation. The vapours from Analyser column are used as heating media in E1 and recovered in the form of condensate. Vapours separated in Effect 1 are used as heating media in Effect 2. Similarly vapour generated in Effect 2 are used as heating medium in Effect 3. Finally the vapours separated in VS3 are condensed in a surface condenser. The condensate from all the effects and condenser shall be pumped out by condensate pumps.

### **1.4 Spent wash generation with integrated mode of operation**

The generation of spent wash with various combinations of sugars in molasses will have a overall impact on operation of the plant & generation of spent wash. The chart of spent wash generation is enclosed herewith for the reference. The assumption basis is that the generation of spent wash is limited to about 4 Litres / Litre of alcohol produced at the maximum. In case of Fermentable sugars ranging between 42 to 48% w/w, the usage of evaporation plant is a must to restrict the generation of the spent wash below 4 litres / litre of alcohol produced.

As the fermentable sugars concentration increases in molasses or in case of the use of B Heavy or B1 Heavy molasses, the F / NF ratio is much better which allows to take

more weak wash recycle back to the fermenter, virtually reducing down the spent wash generation to a great extent as seen from the table. The generation of the spent wash goes as low as 1.5 Litres / Litre of alcohol produced in the distillery itself in which case the use of evaporation for further concentration is not envisaged. Hence, without use of evaporation plant the spent wash generation can be achieved less than 4 litres / litre of alcohol. This is one of the unique features of the Alfa Laval's Continuous Fermentation & Distillation process.

Figure 1: Process flow of Fermentation section

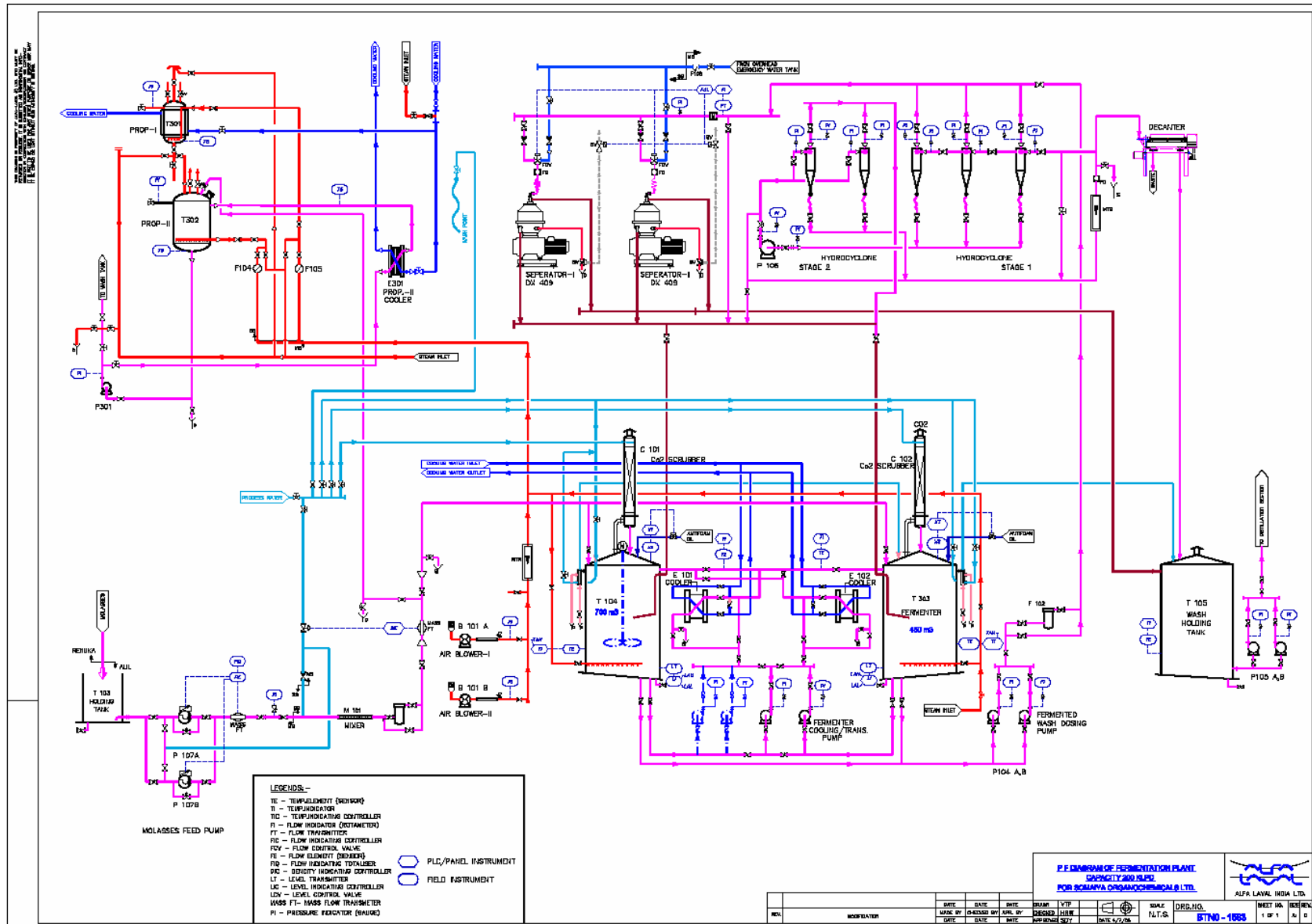



Figure 2: Multiple Effect falling film evaporator

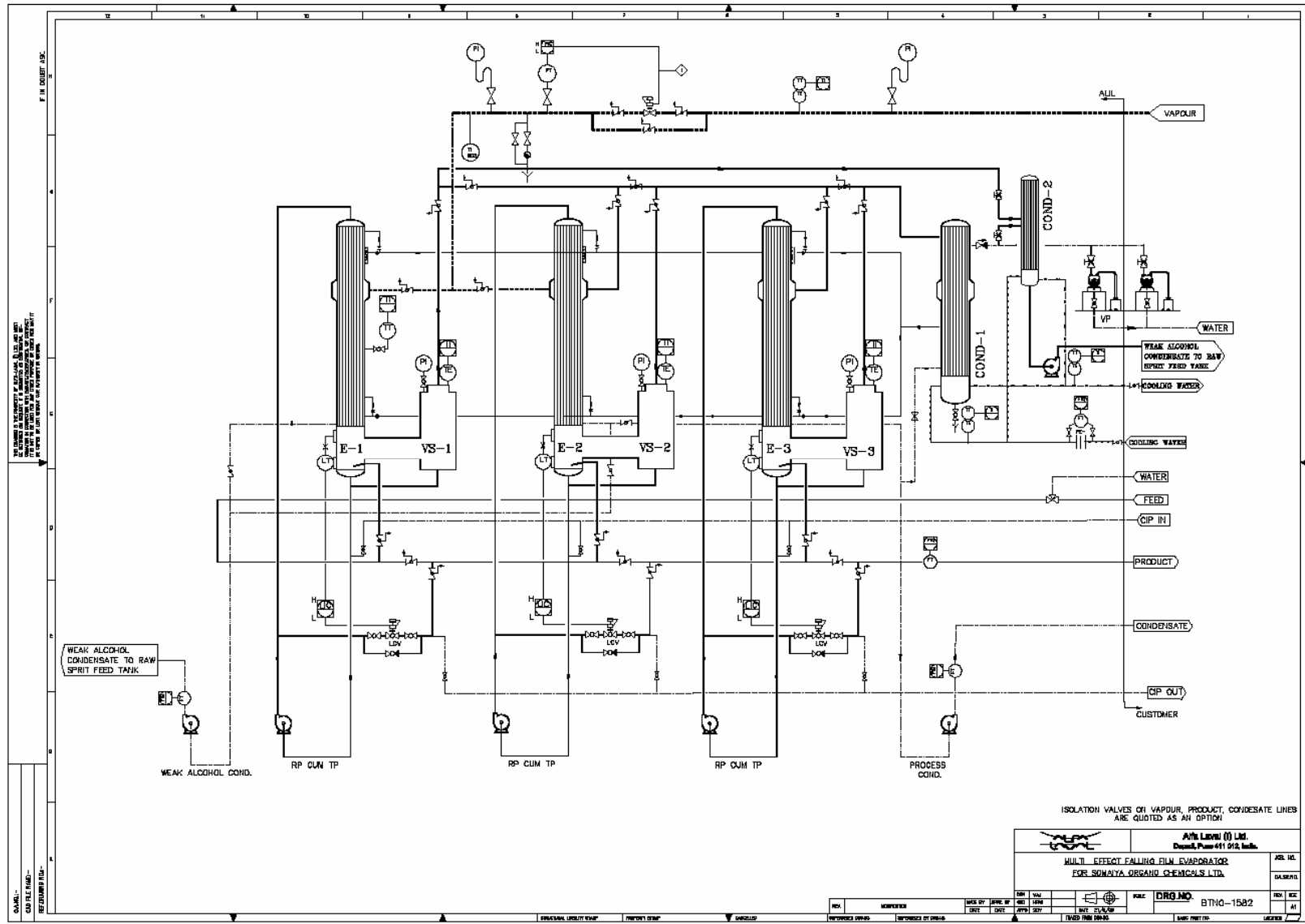

Table 1

ALFA LAVAL CONTINUOUS FERMENTATION, DISTILLATION WITH INTEGRATED EVAPORATOR SYSTEM SPENT WASH GENERATION CHART IN LITRE / LITRE OF ALCOHOL PRODUCED FOR VARIOUS FERMENTABLE SUGARS IN MOLASSES & COMBINATION OF DISSOLVED SOLIDS & ALCOHOL PERCENTAGE IN FERMENTER										
Srl.	MOL SOLIDS	FS	NFS	F / NF RATIO	FERM DS	FERM ALC	SW FROM PLANT	SW SOLIDS	SW FROM EVAP	SW SOLIDS
	% w/w	% w/w	% w/w		% w/w	% v/v	Lit / Lit of Alc	% w/w	Lit / Lit of Alc	% w/w
1	72	40	32.0	1.3	14.0	7.50	7.52	19.40	4.74	29.72
2	72	42	30.0	1.4	14.0	7.50	8.72	19.40	3.96	31.75
3	72	44	28.0	1.8	13.0	7.50	8.44	18.01	3.70	30.25
4	72	46	26.0	1.8	12.0	7.50	8.20	16.63	3.46	28.73
5	72	48	24.0	2.0	12.0	7.50	5.49	16.63	2.77	31.74
6	72	50	22.0	2.3	14.0	7.50	4.14	19.40	-	-
7	72	52	20.0	2.6	14.0	7.50	3.62	19.40	-	-
8	72	54	18.0	3.0	14.0	7.50	3.13	19.40	-	-
9	72	56	16.0	3.5	14.0	7.50	2.69	19.40	-	-
10	72	58	14.0	4.1	14.0	7.50	2.27	19.40	-	-
11	72	60	12.0	5.0	14.0	7.50	1.88	19.40	-	-
12	72	62	10.0	6.2	14.0	7.50	1.52	19.40	-	-
13	72	64	8.0	8.0	13.0	7.50	1.27	18.01	-	-
	<b>NOTE</b>									
1	IN CASE OF MOLASSES, F / NF > 2.0, THE GENERATION OF SPENT WASH IS LOWER AT PLANT LEVEL ITSELF & HENCE EVAPORATION PLANT IS NOT REQUIRED TO BE OPERATED									
2	FINAL CONCENTRATION OF SOLIDS IN SPENT WASH IS RESTRICTED TO 30.0 % w/w FOR FURTHER TREATMENT WITH AEROBIC BIOCOMPOSTING WITH PRESS MUD FROM SUGAR FACTORY									
3	% DS & % ALCOHOL IN THE FERMENTER ARE TO BE ADJUSTED BASED ON THE MASS BALANCE FOR RESTRICTING THE % DS OF FINAL SPENT WASH TO 30 % w/w BASED ON FERMENTABLE SUGARS IN MOLASSES.									

**Table 2**

<b>Alfa Laval Continuous Ferm System Yield Chart for Alcohol / Ton of Molasses for Various Fermentable Sugars</b>				
<b>Formula</b>	<b>%FS x Conversion x %FE x %DE</b>			
	<b>Specific gravity of Alc x Strength of Alc</b>			
<b>Srl.</b>	<b>FS</b>	<b>94.68</b>	<b>95.00</b>	<b>96.00</b>
	<b>% w/w</b>	<b>Lit / Ton</b>	<b>Lit / Ton</b>	<b>Lit / Ton</b>
1	40	242.3	241.5	239.0
2	41	248.4	247.5	245.0
3	42	254.4	253.6	250.9
4	43	260.5	259.6	256.9
5	44	266.5	265.7	262.9
6	45	272.6	271.7	268.9
7	46	278.7	277.7	274.8
8	47	284.7	283.8	280.8
9	48	290.8	289.8	286.8
10	49	296.8	295.8	292.8
11	50	302.9	301.9	298.7
12	51	309.0	307.9	304.7
13	52	315.0	314.0	310.7
14	53	321.1	320.0	316.7
15	54	327.1	326.0	322.6
16	55	333.2	332.1	328.6
17	56	339.2	338.1	334.6
18	57	345.3	344.1	340.6
19	58	351.4	350.2	346.5
20	59	357.4	356.2	352.5
21	60	363.5	362.3	358.5
22	61	369.5	368.3	364.5
23	62	375.6	374.3	370.4
24	63	381.7	380.4	376.4
25	64	387.7	386.4	382.4
26	65	393.8	392.4	388.4

**Table 3**

<b>Spent Wash Characteristics From Alfa Laval Continuous Fermentation, Distillation &amp; Integrated Falling Film Evaporation System</b>				
<b>Characteristics of Spent Wash for Fermentable Sugar of 42 % W/W</b>				
Srl.	Parameters	Unit	Value	Value
1	Brix	Deg Bx	30 - 35	25 - 30
2	Percent Solids	% w/w	27 - 32	22 - 26
3	pH		4.2 - 4.5	4.3 - 4.6
4	COD	mg / lit	280000 - 320000	240000 - 280000
5	BOD ( 3 Day at 27 Deg C )	mg / lit	100000 - 120000	80000 - 100000
6	Total Solids	mg / lit	360000 - 400000	320000 - 360000
7	Total Dissolved Solids	mg / lit	200000 - 240000	170000 - 200000
8	Total Suspended Solids	mg / lit	150000 - 160000	148000 - 155000
9	Conductivity	umhos / cm	40000 - 42000	38000 - 40000
<b>Characteristics of Spent Wash for Fermentable Sugar of 55 % W/W</b>				
Srl.	Parameters	Unit	Value	
1	Brix	Deg Bx	22 - 25	
2	Percent Solids	% w/w	18 - 21	
3	pH		4.2 - 4.5	
4	COD	mg / lit	200000 - 220000	
5	BOD ( 3 Day at 27 Deg C )	mg / lit	60000 - 70000	
6	Total Solids	mg / lit	220000 - 250000	
7	Total Dissolved Solids	mg / lit	180000 - 200000	
8	Total Suspended Solids	mg / lit	40000 - 60000	
9	Conductivity	umhos / cm	35000 - 38000	
<b>Characteristics of Spent Wash for Fermentable Sugar of 64 % W/W</b>				
Srl.	Parameters	Unit	Value	
1	Brix	Deg Bx	22 - 25	
2	Percent Solids	% w/w	18 - 21	
3	pH		4.2 - 4.5	
4	COD	mg / lit	150000 - 180000	
5	BOD ( 3 Day at 27 Deg C )	mg / lit	50000 - 60000	
6	Total Solids	mg / lit	190000 - 210000	
7	Total Dissolved Solids	mg / lit	150000 - 170000	
8	Total Suspended Solids	mg / lit	35000 - 45000	
9	Conductivity	umhos / cm	35000 - 38000	

---

**ANNEXURE II**  
**A Compilation of Legal Instruments**

---

<b>SL. NO.</b>	<b>LEGAL INSTRUMENT (TYPE, REFERENCE, YEAR)</b>	<b>RESPONSIBLE MINISTRIES OR BODIES</b>	<b>CHEMICAL USE CATEGORIES/ POLLUTANTS</b>	<b>OBJECTIVE OF LEGISLATION</b>	<b>RELEVANT ARTICLES/PROVISIONS</b>
1	Air (Prevention and Control of Pollution) Act, 1981 amended 1987	Central Pollution Control Board and State Pollution Control Boards	Air pollutants from chemical industries	The prevention, control and abatement of air pollution	Section 2: Definitions Section 21: Consent from State Boards Section 22: Not to allow emissions exceeding prescribed limits Section 24: Power of Entry and Inspection Section 25: Power to Obtain Information Section 26: Power to Take Samples Section 37-43: Penalties and Procedures
2	Air (Prevention and Control of Pollution) (Union Territories) Rules, 1983	Central Pollution Control Board and State Pollution Control Boards	Air pollutants from chemical industries	The prevention, control and abatement of air pollution	Rule 2: Definitions Rule 9: Consent Applications
3	Water (Prevention and Control of Pollution) Act, 1974 amended 1988	Central Pollution Control Board and State Pollution Control Boards	Water Pollutants from water polluting industries	The prevention and control of water pollution and also maintaining or restoring the wholesomeness of water	Section 2: Definitions Section 20: Power to Obtain Information Section 21: Power to Take Samples Section 23: Power of Entry and Inspection Section 24: Prohibition on Disposal Section 25: Restriction on New Outlet and New Discharge Section 26: Provision regarding existing discharge of sewage or trade effluent Section 27: Refusal or withdrawal of consent by state boards Section 41-49: Penalties and Procedures
4	Water (Prevention and Control of Pollution) Rules, 1975	Central Pollution Control Board and State Pollution	Water Pollutants from water polluting industries	The prevention and control of water pollution and also maintaining or restoring the	Rule 2: Definitions Rule 30: Power to take samples

		Control Boards		wholesomeness of water	Rule 32: Consent Applications
5	The Environment (Protection) Act, 1986, amended 1991	Ministry of Environment and Forests, Central Pollution Control Board and State Pollution Control Boards	All types of environmental pollutants	Protection and Improvement of the Environment	<p>Section 2: Definitions</p> <p>Section 7: Not to allow emission or discharge of environmental pollutants in excess of prescribed standards</p> <p>Section 8: Handling of Hazardous Substances</p> <p>Section 10: Power of Entry and Inspection</p> <p>Section 11: Power to take samples</p> <p>Section 15-19: Penalties and Procedures</p>
6	Environmental (Protection) Rules, 1986 (Amendments in 1999, 2001, 2002, 2002, 2002, 2003, 2004)	Ministry of Environment and Forests, Central Pollution Control Board and State Pollution Control Boards	All types of Environmental Pollutants	Protection and Improvement of the Environment	<p>Rule 2: Definitions</p> <p>Rule 3: Standards for emission or discharge of environmental pollutants</p> <p>Rule 5: Prohibition and restriction on the location of industries and the carrying on process and operations in different areas</p> <p>Rule 13: Prohibition and restriction on the handling of hazardous substances in different areas</p> <p>Rule 14: Submission of environmental statement</p>
7	Hazardous Waste (Management and Handling) Rules, 1989 amended 2000 and 2003	MoEF, CPCB, SPCB, DGFT, Port Authority and Customs Authority	Hazardous Wastes generated from industries using hazardous chemicals	Management & Handling of hazardous wastes in line with the Basel convention	<p>Rule 2: Application</p> <p>Rule 3: Definitions</p> <p>Rule 4: Responsibility of the occupier and operator of a facility for handling of wastes</p> <p>Rule 4A: Duties of the occupier and operator of a facility</p> <p>Rule 4B: Duties of the authority</p> <p>Rule 5: Grant of authorization for handling hazardous wastes</p> <p>Rule 6: Power to suspend or cancel authorization</p>

					<p>Rule 7: Packaging, labeling and transport of hazardous wastes</p> <p>Rule 8: Disposal sites</p> <p>Rule 9: Record and returns</p> <p>Rule 10: Accident reporting and follow up</p> <p>Rule 11: Import and export of hazardous waste for dumping and disposal</p> <p>Rule 12: Import and export of hazardous waste for recycling and reuse</p> <p>Rule 13: Import of hazardous wastes</p> <p>Rule 14: Export of hazardous waste</p> <p>Rule 15: Illegal traffic</p> <p>Rule 16: Liability of the occupier, transporter and operator of a facility</p> <p>Rule 19: Procedure for registration and renewal of registration of recyclers and re-refiners</p> <p>Rule 20: Responsibility of waste generator</p>
8	Manufacture Storage and Import of Hazardous Chemicals Rules, 1989 amended 2000	Ministry of Environment & Forests, Chief Controller of Imports and Exports, CPCB, SPCB, Chief Inspector of Factories, Chief Inspector of Dock Safety, Chief Inspector of Mines, AERB, Chief Controller of Explosives, District Collector or District Emergency Authority, CEES under DRDO	Hazardous Chemicals - Toxic, Explosive, Flammable, Reactive	Regulate the manufacture, storage and import of Hazardous Chemicals	<p>Rule 2: Definitions</p> <p>Rule 4: responsibility of the Occupier</p> <p>Rule 5: Notification of Major Accidents</p> <p>Rule 7-8: Approval and notification of site and updating</p> <p>Rule 10-11: Safety Reports and Safety Audit reports and updating</p> <p>Rule 13: Preparation of Onsite Emergency Plan</p> <p>Rule 14: Preparation of Offsite Emergency Plan</p> <p>Rule 15: Information to persons likely to get affected</p> <p>Rule 16: Proprietary Information</p> <p>Rule 17: Material Safety Data Sheets</p> <p>Rule 18: Import of Hazardous Chemicals</p>
9	Chemical Accidents	CCG, SCG, DCG,	Hazardous Chemicals - Toxic,	Emergency Planning	Rule 2: Definitions



	(Emergency Planning, Preparedness and Response) Rules, 1996	LCG and MAH Units	Explosive, Flammable, Reactive	Preparedness and Response to chemical accidents	Rule 5: Functions of CCG Rule 7: Functions of SCG Rule 9: Functions of DCG Rule 10: Functions of LCG
10	EIA Notification, 2006	MoEF, SPCB	For all the identified developmental activities in the notification	Requirement of environmental clearance before establishment of or modernization / expansion of certain type of industries/ projects.	Requirements and procedure for seeking environmental clearance of projects
11	Public Liability Insurance Act, 1991 amended 1992	Ministry of Environment & Forests, District Collector	Hazardous Substances	To provide immediate relief to persons affected by accident involving hazardous substances	Section 2: Definitions Section 3: Liability to give relief in certain cases on principle of no fault Section 4: Duty of owner to take out insurance policy Section 7A: Establishment of Environmental Relief Fund Section 14-18: Penalties and Offences
12	Public Liability Insurance Rules, 1991 amended 1993	Ministry of Environment & Forests, District Collector	Hazardous Substances	To provide immediate relief to persons affected by accident involving hazardous substances and also for Establishing an Environmental Relief fund	Rule 2: Definitions Rule 6: Establishment of administration of fund Rule 10: Extent of liability Rule 11: Contribution of the owner to environmental relief fund
13	Factories Act, 1948	Ministry of Labour, DGFASLI and Directorate of Industrial Safety and Health/Factories Inspectorate	Chemicals as specified in the Table	Control of workplace environment, and providing for good health and safety of workers	Section 2: Interpretation Section 6: Approval, licensing and registration of factories Section 7A: General duties of the occupier Section 7B: General duties of manufacturers etc., as regards articles and substances for use in factories Section 12: Disposal of wastes and effluents Section 14: Dust and fume Section 36: Precautions against dangerous fumes, gases, etc.

					<p>Section 37: Explosion or inflammable dust, gas, etc.</p> <p>Chapter IVA: Provisions relating to Hazardous processes</p> <p>Section 87: Dangerous operations</p> <p>Section 87A: Power to prohibit employment on account of serious hazard</p> <p>Section 88: Notice of certain accident</p> <p>Section 88A: Notice of certain dangerous occurrences</p> <p>Chapter X: Penalties and procedures</p>
14	The Petroleum Act, 1934	Ministry of Petroleum and Natural Gas	Petroleum (Class A, B and C - as defined in the rules)	Regulate the import, transport, storage, production, refining and blending of petroleum	<p>Section 2: Definitions</p> <p>Section 3: Import, transport and storage of petroleum</p> <p>Section 5: Production, refining and blending of petroleum</p> <p>Section 6: Receptacles of dangerous petroleum to show a warning</p> <p>Section 23-28 Penalties and Procedure</p>
15	The Petroleum Rules, 2002	Ministry of Petroleum and Natural Gas, Ministry of Shipping (for notification of authorized ports for import), Ministry of Environment & Forests or SPCB (for clearance of establishment of loading/unloading facilities at ports) Chief Controller of Explosives, district authority, Commissioner of Customs, Port	Petroleum (Class A, B and C - as defined in the rules)	Regulate the import, transport, storage, production, refining and blending of petroleum	<p>Rule 2: Definition</p> <p>Chapter I part II: General Provision</p> <p>Chapter II: Importation of Petroleum</p> <p>Chapter III: Transport of Petroleum</p> <p>Chapter VII: Licenses</p>

		Conservator, State Maritime Board (Import)			
16	The Explosives Act, 1884	Ministry of Commerce and Industry (Department of Explosives)	Explosive substances as defined under the Act	To regulate the manufacture, possession, use, sale, transport, export and import of explosives with a view to prevent accidents	Section 4: Definition Section 6: Power for Central government to prohibit the manufacture, possession or importation of especially dangerous explosives Section 6B: Grant of Licenses
17	The Explosive Rules, 1983	Ministry of Commerce and Industry and Chief Controller of Explosives, port conservator, customs collector, railway administration	Explosive substances as defined under the Act	To regulate the manufacture, possession, use, sale, transport, export and import of explosives with a view to prevent accidents	Rule 2: Definition Chapter II: General Provisions Chapter III: Import and Export Chapter IV: Transport Chapter V: Manufacture of explosives Chapter VI: Possession sale and use Chapter VII: Licenses
18	The Gas Cylinder Rules, 2004	Ministry of Commerce and Industry and Chief Controller of Explosives, port conservator, customs collector, DGCA, DC, DM, Police (sub inspector to commissioner)	Gases (Toxic, non toxic and non flammable, non toxic and flammable, Dissolved Acetylene Gas, Non toxic and flammable liquefiable gas other than LPG, LPG	Regulate the import, storage, handling and transportation of gas cylinders with a view to prevent accidents	Rule 2: Definition Chapter II: General Provisions Chapter III: Importation of Cylinder Chapter IV: Transport of Cylinder Chapter VII: Filling and Possession
19	The Static and Mobile Pressure Vessels (Unfired) Rules, 1981	Ministry of Commerce and Industry and Chief Controller of Explosives, port conservator, customs collector, DGCA, DC, DM, Police (sub inspector to	Gases (Toxic, non toxic and non flammable, non toxic and flammable, Dissolved Acetylene Gas, Non toxic and flammable liquefiable gas other than LPG, LPG	Regulate the import, manufacture, design, installation, transportation, handling, use and testing of mobile and static pressure vessels (unfired) with a view to prevent accidents	Rule 2: Definition Chapter III: Storage Chapter IV: Transport Chapter V: Licenses

		commissioner)			
20	The Motor Vehicle Act, 1988	Ministry of Shipping, Road Transport and Highways	Hazardous and Dangerous Goods	To consolidate and amend the law relating to motor vehicles	Section 2: Definition Chapter II: Licensing of drivers of motor vehicle Chapter VII: Construction equipment and maintenance of motor vehicles
21	The Central Motor Vehicle Rules, 1989	Ministry of Shipping, Road Transport and Highways	Hazardous and Dangerous Goods	To consolidate and amend the law relating to motor vehicles including to regulate the transportation of dangerous goods with a view to prevent loss of life or damage to the environment	Rule 2: Definition Rule 9: Educational qualification for driver's of goods carriages carrying dangerous or hazardous goods Rule 129: Transportation of goods of dangerous or hazardous nature to human life Rule 129A: Spark arrestors Rule 130: Manner of display of class labels Rule 131: Responsibility of the consignor for safe transport of dangerous or hazardous goods Rule 132: Responsibility of the transporter or owner of goods carriage Rule 133: Responsibility of the driver Rule 134: Emergency Information Panel Rule 135: Driver to be instructed Rule 136: Driver to report to the police station about accident Rule 137: Class labels
22	Drug and Cosmetics Act, 1940	Ministry of Health and Family Welfare	To all types of drugs and cosmetics	To regulate the import, manufacture, distribution and sale of drugs	Section 2: Definitions Chapter III: Import of Drugs and Cosmetics Chapter IV: Manufacture, Sale and Distribution of Drugs and Cosmetics
23	The Prevention of Food Adulteration Act, 1954	Ministry of Health and Family Welfare	All food grade chemicals, colorants, preservatives, poison metals, etc.	To prevent the food adulteration	Section 2: Definitions Section 5: Prohibition of import of certain articles of food Section 7: Prohibition of manufacture, sale

					<p>etc., of certain articles of food</p> <p>Section 15: Notification of food poisoning</p> <p>Section 16: Penalties</p>
24	The Prevention of Food Adulteration Rules, 1955	Ministry of Health and Family Welfare	All food grade chemicals, colorants, preservatives, poison metals, etc.	To prevent the food adulteration	<p>Section 2: Definitions</p> <p>Part VI: Colouring Matter</p> <p>Part X: Preservatives</p> <p>Part XI: Poisonous Metals</p> <p>Part XIA: Crop Contaminants and Naturally Occurring Toxic Substances</p> <p>Part XII: Anti-Oxidants, Emulsifying and Stabilizing and Anticaking Agents</p> <p>Part XIII: Flavoring Agents and Related Substances</p> <p>Part XIII-A: Carry Over of Food Additives</p> <p>Part XVI: Sequestering and Buffering Agents (Acids, Bases and Salts)</p> <p>Part XVIII: Antibiotic and other Pharmacologically Active Substances</p> <p>Part XIX: Use of Food Additives in Food Products</p>

---

**ANNEXURE III**  
**General Standards for Discharge of Environmental Pollutants**

---

**Table: Water Quality Standards**

S. No.	Parameter	Standards			
		Inland Surface Water	Public Sewer	Land for Irrigation	Marine Coastal Areas
1.	2.	3.			
		(a)	(b)	(c)	(d)
1.	Colour and odour	See Note-1	—	See Note-1	See Note-1
2.	Suspended Solids, mg/l, Max	100	600	200	(a) For process waste water-100 (b) For cooling water effluent-10 per cent above total suspended matter of influent cooling water.
3.	Particle size of suspended solids	Shall pass 850 micron IS Sieve	—	—	(a) Floatable solids, Max 3 mm (b) Settleable solids Max 850 microns.
4.	Dissolved solids (inorganic), mg/a, mac	2100	2100	2100	—
5.	pH value	5.5 to 9.0	5.5 to 9.0	5.5 to 9.0	5.5 to 9.0
6.	Temperature °C, Max	Shall not exceed 40 in any section of the stream within 15 meters down stream from the effluent outlet	45 at the point of discharge	—	45 at the point of discharge
7.	Oil and grease, mg/l, max	10	20	10	20
8.	Total residual chlorine, mg/l, Max.	1.0	—	—	1.0
9.	Ammonical nitrogen (as N), mg/l, Max.	50	50	—	50
10.	Total Kjeldahl nitrogen (as N), mg/l, Max.	100	—	—	100
11.	Free Ammonia (as NH <sub>3</sub> ), mg/l, Max.	5.0	—	—	5.0
12.	Biochemical Oxygen Demand (5 days at 20°C) Max.	30	350	100	100
13.	Chemical Oxygen Demand, mg/l, Max.	250	—	—	250
14.	Arsenic (as As), mg/l, Max.	0.2	0.2	0.2	0.2
15.	Mercury (as Hg), mg/l, Max.	0.01	0.01	—	0.01
16.	Lead (as Pb), mg/l, Max.	0.1	1.0	—	1.0
17.	Cadmium (as Cd), mg/l, Max.	2.0	1.0	—	2.0

18.	Hexavalent chromium (as Cr+6) mg/l, Max.	0.1	2.0	—	1.0
19.	Total chromium as (Cr), mg/l, Max.	2.0	2.0	—	2.0
20.	Copper (as Cu), mg/l, Max.	3.0	3.0	—	3.0
21.	Zinc (as Zn), mg/l, Max.	5.0	15	—	15
22.	Selenium (as Se), mg/l, Max.	0.05	0.05	—	0.05
23.	Nickel (as Ni), mg/l, Max.	3.0	3.0	—	5.0
24.	Boron (as B), mg/l, Max.	2.0	2.0	2.0	—
25.	Percent Sodium, Max.	—	60	60	—
26.	Residual sodium carbonate, mg/l, Max.	—	—	5.0	—
27.	Cyanide (as CN), mg/l, Max.	0.2	2.0	0.2	0.2
28.	Chloride (as Cl), mg/l, Max.	1000	1000	600	(a)
29.	Fluoride (as F), mg/l, Max.	2.0	15	—	15
30.	Dissolved Phosphates (as P), mg/l, Max.	5.0	—	—	—
31.	Sulphate (as SO <sub>4</sub> ), mg/l, Max.	1000	1000	1000	—
32.	Sulphide (as S), mg/l, Max.	2.0	—	—	5.0
33.	Pesticides	Absent	Absent	Absent	Absent
34.	Phenolic compounds (as C <sub>6</sub> H <sub>5</sub> OH), mg/l, Max.	1.0	5.0	—	5.0
35.	Radioactive materials				
	(a) Alpha emitters MC/ml, Max.	10 <sup>-7</sup>	10 <sup>-7</sup>	10 <sup>-8</sup>	10 <sup>-7</sup>
	(b) Beta emitters uc/ml, Max.	10 <sup>-6</sup>	10 <sup>-6</sup>	10 <sup>-7</sup>	10 <sup>-6</sup>

Note :-

1. All efforts should be made to remove colour and unpleasant odour as far as practicable.
2. The standards mentioned in this notification shall apply to all the effluents discharged such as industrial mining and mineral processing activities municipal sewage etc.



## Table: Noise Standards

Ambient air quality standards in respect of noise

Area Code	Category of Area	Limits in dB (A) Leq	
		Day Time	Night Time
(A)	Industrial area	75	70
(B)	Commercial area	65	55
(C)	Residential area	55	45
(D)	Silence zone	50	40

Note :

1. Day time is reckoned in between 6.00 AM and 9.00 PM
2. Night time is reckoned in between 9.00 PM and 6.00 AM
3. Silence zone is defined as areas upto 100 meters around such premises as hospitals, educational institutions and courts. The Silence zones are to be declared by the Competent Authority.
4. Use of vehicular horns, loudspeakers and bursting of crackers shall be banned in these zones.
5. Mixed categories of areas should be declared as one of the four above mentioned categories by the Competent Authority and the corresponding standards shall apply.

## Standards/Guidelines for Control of Noise Pollution from Stationary Diesel Generator (DG) Sets

### (A) Noise Standards for DG Sets (15-500 KVA)

The total sound power level,  $L_w$ , of a DG set should be less than,  $94+10 \log_{10} (KVA)$ , dB (A), at the manufacturing stage, where, KVA is the nominal power rating of a DG set.

This level should fall by 5 dB (A) every five years, till 2007, i.e. in 2002 and then in 2007.

### (B) Mandatory acoustic enclosure/acoustic treatment of room for stationary DG sets (5 KVA and above)

Noise from the DG set should be controlled by providing an acoustic enclosure or by treating the room acoustically.

The acoustic enclosure/acoustic treatment of the room should be designed for minimum 25 dB(A) Insertion Loss or for meeting the ambient noise standards, whichever is on the higher side (if the actual ambient noise is on the higher side, it may not be possible to check the performance of the acoustic enclosure/acoustic treatment. Under such circumstances the performance may be checked for noise reduction upto actual ambient noise level, preferably, in the night time). The measurement for Insertion Loss may be done at different points at 0.5m from the acoustic enclosure/room, and then averaged.

The DG set should also be provide with proper exhaust muffler with Insertion Loss of minimum 25 dB(A).

### (C) Guidelines for the manufacturers/users of DG sets (5 KVA and above)

1. The manufacturer should offer to the user a standard acoustic enclosure of 25 dB(A) Insertion Loss and also a suitable exhaust muffler with Insertion Loss of 25 dB(A).

2. The user should make efforts to bring down the noise levels due to the DG set, outside his premises, within the ambient noise requirements by proper siting and control measures.
3. The manufacturer should furnish noise power levels of the unlicensed DG sets as per standards prescribed under (A)
4. The total sound power level of a DG set, at the user's end, shall be within 2 dB(A) of the total sound power level of the DG set, at the manufacturing stage, as prescribed under (A).
5. Installation of a DG set must be strictly in compliance with the recommendation of the DG set manufacturer.
6. A proper routine and preventive maintenance procedure for the DG set should be set and followed in consultation with the DG set manufacturer which would help prevent noise levels of the DG set from deteriorating with use.

**Order of the Lt. Governor of Delhi in respect of D.G. Sets (5th December, 2001)**

In exercise of the powers conferred by section 5 of the Environment (Protection) Act, 1986, (29 of 1986), read with the Government of India, Ministry of Home Affairs notification S.O. 667 (E) bearing No. F.No. U-11030/J/91-VTL dated 10th September, 1992, the Lt. Governor of Government of National Capital of Delhi hereby directs to all owners/users of generators sets in the National Capital Territory of Delhi as follows :-

1. that generator sets above the capacity of 5 KVA shall not be operated in residential areas between the hours of 10.00 PM to 6.00 AM;
2. that the generator sets above the capacity of 5 KVA in all areas residential/commercial/industrial shall operate only with the mandatory acoustic enclosures and other standards prescribed in the Environment (Protection) Rules, 1986;
3. that mobile generator sets used in social gatherings and public functions shall be permitted only if they have installed mandatory acoustic enclosures and adhere to the prescribed standards for noise and emission as laid down in the Environment (Protection) Rules, 1986.

The contravention of the above directions shall make the offender liable for prosecution under section 15 of the said Act which stipulates punishment of imprisonment for a term which may extend to five years with fine which may extend to one lakh rupees, or with both, and in case the failure of contravention continues, with additional fine which may extend to five thousand rupees for every day during which such failure or contravention continues after the conviction for the first such failure or contravention and if still the failure or contravention continues beyond a period of one year after the date of contravention, the offender continues beyond a period of one year after the date of contravention, the offender shall be punishable with imprisonment for a term which may extend to seven years.

**Order Dated: 21st June, 2002**

In exercise of the powers conferred by section 5 of the Environment (Protection) Act, 1986 (29 of 1986) read with the Govt. of India, Ministry of Home Affairs notification S.O. 667(E) bearing No. U-11030/J/91-VTL dated the 10th September, 1992, the Lt. Governor Govt. of the National Capital Territory of Delhi hereby makes the following amendment/modification in his order dated the 5th December, 2001 regarding the operation of generator sets, namely:-

**Amendments/modifications**

In the above said order, for clause(1), the following shall be substituted, namely:-

“(1) that the generator sets above 5KVA shall not be operated in residential areas between the hours from 10.00 p.m. to 6.00 a.m. except generator sets of Group Housing Societies and Multi-storey residential apartments”.

## **DIESEL GENERATOR SETS: STACK HEIGHT**

The minimum height of stack to be provided with each generator set can be worked out using the following formula:

$$H = h + 0.2 \times \text{OKVA}$$

H = Total height of stack in metre

h = Height of the building in metres where the generator set is installed

KVA = Total generator capacity of the set in KVA

Based on the above formula the minimum stack height to be provided with different range of generator sets may be categorized as follows:

For Generator Sets	Total Height of stack in metre
50 KVA	Ht. of the building + 1.5 metre
50-100 KVA	Ht. of the building + 2.0 metre
100- 150 KVA	Ht. of the building + 2.5 metre
150-200 KVA	Ht. of the building + 3.0 metre
200-250 KVA	Ht. of the building + 3.5 metre
250-300 KVA	Ht. of the building + 3.5 metre

Similarly for higher KVA ratings a stack height can be worked out using the above formula

Source: Evolved By CPCB

[Emission Regulations Part IV: COINDS/26/1986-87]

---

**ANNEXURE IV**  
**Form 1 (Application Form for Obtaining EIA Clearance)**

---

## FORM 1

### (I) BASIC INFORMATION

S. No.	Item	Details
1.	Name of the project/s	
2.	S.No. in the schedule	
3.	Proposed capacity/area/length/tonnage to be handled/command area/lease area/number of wells to be drilled	
4.	New/Expansion/Modernization	
5.	Existing Capacity/Area etc.	
6.	Category of Project i.e., 'A' or 'B'	
7.	Does it attract the general condition? If yes, please specify.	
8.	Does it attract the specific condition? If yes, Please specify.	
9.	Location	
	Plot/Survey/Khasra No.	
	Village	
	Tehsil	
	District	
	State	
10.	Name of the applicant	
11.	Registered Address	
12.	Address for correspondence:	
	Name	
	Designation (Owner/Partner/CEO)	
	Address	
	Pin Code	
	E-mail	
	Telephone No.	
	Fax No.	
13.	Details of alternative Sites examined, if any location of these sites should be shown on a toposheet.	Village-District-State 1. 2. 3.

<b>S. No.</b>	<b>Item</b>	<b>Details</b>
14.	Interlined Projects	
15.	Whether separate application of interlined project has been submitted	
16.	If yes, date of submission	
17.	If no, reason	
18.	Whether the proposal involves approval/clearance under: The Forest (Conservation) Act, 1980 The Wildlife (Protection) Act, 1972 The C.R.Z. Notification, 1991	
19.	Forest land involved (hectares)	
20.	Whether there is any litigation pending against the project and/or land in which the project is propose to be set up Name of the Court Case No. Orders/directions of the Court, if any and its relevance with the proposed project.	

## **(II) ACTIVITY**

**1. Construction, operation or decommissioning of the Project involving actions, which will cause physical changes in the locality (topography, land use, changes in water bodies, etc.)**

<b>S.No.</b>	<b>Information/Checklist confirmation</b>	<b>Yes/No</b>	<b>Details thereof (with approximate quantities /rates, wherever possible) with source of information data</b>
1.1	Permanent or temporary change in land use, land cover or topography including increase in intensity of land use (with respect to local land use plan)		
1.2	Clearance of existing land, vegetation and buildings?		
1.3	Creation of new land uses?		
1.4	Pre-construction investigations e.g. bore houses, soil testing?		
1.5	Construction works?		

S.No.	Information/Checklist confirmation	Yes/No	Details thereof (with approximate quantities /rates, wherever possible) with source of information data
1.6	Demolition works?		
1.7	Temporary sites used for construction works or housing of construction workers?		
1.8	Above ground buildings, structures or earthworks including linear structures, cut and fill or excavations		
1.9	Underground works including mining or tunneling?		
1.10	Reclamation works?		
1.11	Dredging?		
1.12	Offshore structures?		
1.13	Production and manufacturing processes?		
1.14	Facilities for storage of goods or materials?		
1.15	Facilities for treatment or disposal of solid waste or liquid effluents?		
1.16	Facilities for long term housing of operational workers?		
1.17	New road, rail or sea traffic during construction or operation?		
1.18	New road, rail, air waterborne or other transport infrastructure including new or altered routes and stations, ports, airports etc?		
1.19	Closure or diversion of existing transport routes or infrastructure leading to changes in traffic movements?		
1.20	New or diverted transmission lines or pipelines?		
1.21	Impoundment, damming, culverting, realignment or other changes to the hydrology of watercourses or aquifers?		
1.22	Stream crossings?		
1.23	Abstraction or transfers of water form ground or surface waters?		
1.24	Changes in water bodies or the land surface affecting drainage or run-off?		
1.25	Transport of personnel or materials for construction, operation or decommissioning?		

S.No.	Information/Checklist confirmation	Yes/No	Details thereof (with approximate quantities /rates, wherever possible) with source of information data
1.26	Long-term dismantling or decommissioning or restoration works?		
1.27	Ongoing activity during decommissioning which could have an impact on the environment?		
1.28	Influx of people to an area in either temporarily or permanently?		
1.29	Introduction of alien species?		
1.30	Loss of native species or genetic diversity?		
1.31	Any other actions?		

**2. Use of Natural resources for construction or operation of the Project (such as land, water, materials or energy, especially any resources which are non-renewable or in short supply):**

S.No.	Information/checklist confirmation	Yes/No	Details thereof (with approximate quantities /rates, wherever possible) with source of information data
2.1	Land especially undeveloped or agricultural land (ha)		
2.2	Water (expected source & competing users) unit: KLD		
2.3	Minerals (MT)		
2.4	Construction material – stone, aggregates, sand / soil (expected source – MT)		
2.5	Forests and timber (source – MT)		
2.6	Energy including electricity and fuels (source, competing users) Unit: fuel (MT), energy (MW)		
2.7	Any other natural resources (use appropriate standard units)		



**3. Use, storage, transport, handling or production of substances or materials, which could be harmful to human health or the environment or raise concerns about actual or perceived risks to human health.**

<b>S.No</b>	<b>Information/Checklist confirmation</b>	<b>Yes/No</b>	<b>Details thereof (with approximate quantities/rates, wherever possible) with source of information data</b>
3.1	Use of substances or materials, which are hazardous (as per MSIHC rules) to human health or the environment (flora, fauna, and water supplies)		
3.2	Changes in occurrence of disease or affect disease vectors (e.g. insect or water borne diseases)		
3.3	Affect the welfare of people e.g. by changing living conditions?		
3.4	Vulnerable groups of people who could be affected by the project e.g. hospital patients, children, the elderly etc.,		
3.5	Any other causes		

**4. Production of solid wastes during construction or operation or decommissioning (MT/month)**

<b>S.No.</b>	<b>Information/Checklist confirmation</b>	<b>Yes/No</b>	<b>Details thereof (with approximate quantities/rates, wherever possible) with source of information data</b>
4.1	Spoil, overburden or mine wastes		
4.2	Municipal waste (domestic and or commercial wastes)		
4.3	Hazardous wastes (as per Hazardous Waste Management Rules)		
4.4	Other industrial process wastes		
4.5	Surplus product		
4.6	Sewage sludge or other sludge from effluent treatment		
4.7	Construction or demolition wastes		
4.8	Redundant machinery or equipment		

<b>S.No.</b>	<b>Information/Checklist confirmation</b>	<b>Yes/No</b>	<b>Details thereof (with approximate quantities/rates, wherever possible) with source of information data</b>
4.9	Contaminated soils or other materials		
4.10	Agricultural wastes		
4.11	Other solid wastes		

**5. Release of pollutants or any hazardous, toxic or noxious substances to air (kg/hr)**

<b>S.No</b>	<b>Information/Checklist confirmation</b>	<b>Yes/No</b>	<b>Details thereof (with approximate quantities/rates, wherever possible) with source of information data</b>
5.1	Emissions from combustion of fossil fuels from stationary or mobile sources		
5.2	Emissions from production processes		
5.3	Emissions from materials handling including storage or transport		
5.4	Emissions from construction activities including plant and equipment		
5.5	Dust or odours from handling of materials including construction materials, sewage and waste		
5.6	Emissions from incineration of waste		
5.7	Emissions from burning of waste in open air (e.g. slash materials, construction debris)		
5.8	Emissions from any other sources		

**6. Generation of Noise and Vibration, and Emissions of Light and Heat:**

<b>S.No.</b>	<b>Information/Checklist confirmation</b>	<b>Yes/No</b>	<b>Details thereof (with approximate quantities/rates, wherever possible) with source of information data with source of information data</b>
6.1	From operation of equipment e.g. engines, ventilation plant, crushers		
6.2	From industrial or similar processes		
6.3	From construction or demolition		
6.4	From blasting or piling		
6.5	From construction or operational traffic		
6.6	From lighting or cooling systems		
6.7	From any other sources		

**7. Risks of contamination of land or water from releases of pollutants into the ground or into sewers, surface waters, groundwater, coastal waters or the sea:**

<b>S.No.</b>	<b>Information/Checklist confirmation</b>	<b>Yes/No</b>	<b>Details thereof (with approximate quantities/rates, wherever possible) with source of information data</b>
7.1	From handling, storage, use or spillage of hazardous materials		
7.2	From discharge of sewage or other effluents to water or the land (expected mode and place of discharge)		
7.3	By deposition of pollutants emitted to air into the land or into water		
7.4	From any other sources		
7.5	Is there a risk of long term build up of pollutants in the environment from these sources?		

**8. Risk of accidents during construction or operation of the Project, which could affect human health or the environment**

<b>S.No</b>	<b>Information/Checklist confirmation</b>	<b>Yes/No</b>	<b>Details thereof (with approximate quantities/rates, wherever possible) with source of information data</b>
8.1	From explosions, spillages, fires etc from storage, handling, use or production of hazardous substances		
8.2	From any other causes		
8.3	Could the project be affected by natural disasters causing environmental damage (e.g. floods, earthquakes, landslides, cloudburst etc)?		

**9. Factors which should be considered (such as consequential development) which could lead to environmental effects or the potential for cumulative impacts with other existing or planned activities in the locality**

<b>S. No.</b>	<b>Information/Checklist confirmation</b>	<b>Yes/No</b>	<b>Details thereof (with approximate quantities/rates, wherever possible) with source of information data</b>
9.1	Lead to development of supporting facilities, ancillary development or development stimulated by the project which could have impact on the environment e.g.: <ul style="list-style-type: none"> <li>▪ Supporting infrastructure (roads, power supply, waste or waste water treatment, etc.)</li> <li>▪ housing development</li> <li>▪ extractive industries</li> <li>▪ supply industries</li> <li>▪ other</li> </ul>		
9.2	Lead to after-use of the site, which could have an impact on the environment		
9.3	Set a precedent for later developments		
9.4	Have cumulative effects due to proximity to other existing or planned projects with similar effects		

### (III) ENVIRONMENTAL SENSITIVITY

S.No.	Areas	Name/ Identity	Aerial distance (within 15 km.)  Proposed project location boundary
1	Areas protected under international conventions, national or local legislation for their ecological, landscape, cultural or other related value		
2	Areas which are important or sensitive for ecological reasons - Wetlands, watercourses or other water bodies, coastal zone, biospheres, mountains, forests		
3	Areas used by protected, important or sensitive species of flora or fauna for breeding, nesting, foraging, resting, over wintering, migration		
4	Inland, coastal, marine or underground waters		
5	State, National boundaries		
6	Routes or facilities used by the public for access to recreation or other tourist, pilgrim areas		
7	Defence installations		
8	Densely populated or built-up area		
9	Areas occupied by sensitive man-made land uses ( <i>hospitals, schools, places of worship, community facilities</i> )		
10	Areas containing important, high quality or scarce resources ( <i>ground water resources, surface resources, forestry, agriculture, fisheries, tourism, minerals</i> )		
11	Areas already subjected to pollution or environmental damage. ( <i>those where existing legal environmental standards are exceeded</i> )		
12	Areas susceptible to natural hazard which could cause the project to present environmental problems ( <i>earthquakes, subsidence, landslides, erosion, flooding or extreme or adverse climatic conditions</i> )		

#### **(IV) PROPOSED TERMS OF REFERENCE FOR EIA STUDIES**

“I hereby given undertaking that the data and information given in the application and enclosure are true to the best of my knowledge and belief and I am aware that if any part of the data and information submitted is found to be false or misleading at any stage, the project will be rejected and clearance give, if any to the project will be revoked at our risk and cost.

Date: \_\_\_\_\_

Place: \_\_\_\_\_

Signature of the applicant  
With Name and Full Address  
(Project Proponent / Authorized Signatory)

#### **NOTE:**

1. The projects involving clearance under Coastal Regulation Zone Notification, 1991 shall submit with the application a C.R.Z. map duly demarcated by one of the authorized, agencies, showing the project activities, w.r.t. C.R.Z. and the recommendations of the State Coastal Zone Management Authority. Simultaneous action shall also be taken to obtain the requisite clearance under the provisions of the C.R.Z. Notification, 1991 for the activities to be located in the CRZ.
2. The projects to be located within 10km of the National Parks, Sanctuaries, Biosphere Reserves, Migratory Corridors of Wild Animals, the project proponent shall submit the map duly authenticated by Chief Wildlife Warden showing these features vis-à-vis the project location and the recommendations or comments of the Chief Wildlife Warden thereon.”

---

**ANNEXURE V**  
**CRITICALLY POLLUTED AREAS AS IDENTIFIED BY CPCB**

---

**Details of Critically Polluted Industrial Areas and Clusters / Potential Impact Zone in terms of the Office Memorandum no. J-11013/5/2010-IA.II(I) dated 13.1.2010**

<b>S. No.</b>	<b>Critically Polluted Industrial Area and CEPI</b>	<b>Industrial Clusters/ Potential Impact Zones</b>
1.	<b>Ankeshwar (Gujarat)</b>  <b>CEPI-88.50(Ac Wc Lc)</b>	GIDC Ankeshwar and GIDC, Panoli
2	<b>Vapi (Gujarat)</b>  <b>CEPI-88.09(Ac Wc Lc)</b>	GIDC Vapi
3	<b>Ghaziabad (Uttar Pradesh)</b>  <b>CEPI-87.37(Ac_Wc_Lc)</b>	<p><b>Sub-cluster A</b></p> <ul style="list-style-type: none"> <li>• Mohan nagar industrial area</li> <li>• Rajinder nagar industrial area</li> <li>• Sahibabad industrial area</li> </ul> <p><b>Sub-cluster B</b></p> <ul style="list-style-type: none"> <li>• Pandav nagar industrial area</li> <li>• Kavi nagar industrial area</li> <li>• Bulandshahar road industrial area</li> <li>• Amrit nagar</li> <li>• Aryanagar industrial area</li> </ul> <p><b>Sub-cluster C</b></p> <ul style="list-style-type: none"> <li>• Merrut road industrial are</li> </ul> <p><b>Sub-cluster D</b></p> <ul style="list-style-type: none"> <li>• Loni industrial area</li> <li>• Loni Road industrial area</li> <li>• Roop nagar industrial area</li> </ul> <p><b>Sub-cluster E</b></p> <ul style="list-style-type: none"> <li>• Hapur Road industrial area</li> <li>• Dasna</li> <li>• Philkura</li> </ul> <p><b>Sub-cluster F (Other scattered industrial areas)</b></p> <ul style="list-style-type: none"> <li>• South side of GT road</li> <li>• Kavi Nagar</li> <li>• Tronica city</li> <li>• Anand Nagar</li> <li>• Jindal Nagar</li> <li>• Prakash Nagar</li> <li>• Rural industrial estate</li> </ul>
4	<b>Chandrapur (Maharashtra)</b>  <b>CEPI-83.88 (Ac Wc Lc)</b>	Chandrapur (MIDC Chandrapur, Tadali, Ghuggus, Ballapur)
5	<b>Kobra (Chhatisgarh)</b>  <b>CEPI-83.00 (Ac Ws Lc)</b>	a) Industrial areas and their townships of NTPC, BALCO, CSEB (East) & CSEB (West) b) Korba town
6	<b>Bhiwadi (Rajasthan)</b>  <b>CEPI-82.91 (Ac_Wc_Ls)</b>	a) RIICO industrial areas Phase I to IV b) Bhiwadi town c) Other surrounding industrial areas: Chopanki, Rampura Mundana, Khuskhera Phase I to III
7	<b>Angul Talcer(Orissa)</b>  <b>CEPI-82.09 (Ac_Wc_Lc)</b>	a) MCL Coal mining area, Augul – Talcer region b) Industrial area (60 km x 45 km)  Following blocks of Augul district: - Kohina block - Talcher block - Angul block - Chhendipada block



		- Banarpal block And Odapada block of Dhenkamal district
8	<b>Vellore (North Arcot) (Tamil Nadu)</b>  <b>CEPI-81.79 (Ac Wc Lc)</b>	Ranipet, SIPCOT industrial complex
9	<b>Singrauli (Uttar Pradesh)</b>  <b>CEPI-81.73 (Ac_Wc_Ls)</b>	Sonebhadra (UP) <ul style="list-style-type: none"> <li>• Dala-Tola</li> <li>• Obra</li> <li>• Renukoot</li> <li>• Anpara</li> <li>• Renusagar</li> <li>• Kakri</li> <li>• Dudhichuwa</li> <li>• Bina</li> <li>• Khadia</li> <li>• Shakti nagar</li> <li>• Rihand nagar</li> <li>• Bijpur</li> </ul> Singrauli (Madhya Pradesh) Vindhyachal nagar and Jaynat, Nigahi, Dudhichua, Amlohri & Jhingurdah townships
10	<b>Ludhiana (Punjab)</b>  <b>CEPI-81.66 (Ac_Wc_Ls)</b>	Ludhiana municipal limits covering industrial clusters: <ul style="list-style-type: none"> <li>• Focal point along with NH-I- Total eight phase</li> <li>• Industrial area-B- from sherpur chowk to Gill road &amp; Gill road to Miller Kotla road (left side of road)</li> <li>• Mixed industrial area – right side of Gill road</li> <li>• Industrial area –C (near Juglana village)</li> <li>• Industrial area A &amp; extension: area between old GT road and Ludhiana bypass road</li> <li>• Industrial estate: near Dholwal chowk</li> <li>• Mixes industrial area (MIA) Miller gunj</li> <li>• MIA – bypass road</li> <li>• Bahdur industrial area</li> <li>• Tejpur industrial complex</li> </ul>
11	<b>Nazafgarh drain basin, Delhi</b>  <b>CEPI-79.54 (As_Wc_Lc)</b>	Industrila areas: Anand Parvat, Naraina, Okhla and Wazirpur
12	<b>Noida (Uttar Pradesh)</b>  <b>CEPI-78.90 (Ac_Wc_Lc)</b>	Territorial Jurisdiction of: <ul style="list-style-type: none"> <li>• Noida Phase-1</li> <li>• Noida Phase-2</li> <li>• Noida Phase-3</li> <li>• Surajpur industrial area</li> <li>• Greater Noida industrial area</li> <li>• Village- Chhaparaula</li> </ul>
13	<b>Dhanbad (Jharkhand)</b>  <b>CEPI-78.63 (Ac_Ws_Lc)</b>	Four blocks of Dhanbad district: <ul style="list-style-type: none"> <li>• Sadar (Dhanbad Municipality)</li> <li>• Jharia (Jharia Municipality, Sindri industrial area)</li> <li>• Govindpur (Govindpur industrial estate)</li> <li>• Nirsa</li> </ul>
14	<b>Dombivalli (Maharashtra)</b>  <b>CEPI-78.41 (Ac_Wc_Ls)</b>	MIDC Phase- I, Phase- II
15	<b>Kanpur (Uttar Pradesh)</b>  <b>CEPI-78.09 (Ac_Wc_Ls)</b>	Industrial areas: <ul style="list-style-type: none"> <li>• Dada nagar</li> <li>• Panki</li> <li>• Fazalganj</li> </ul>

		<ul style="list-style-type: none"> <li>• Vijay nagar</li> <li>• Jajmau</li> </ul>
16	<b>Cuddalore (Tamil Nadu)</b> CEPI-77.45 (As Wc Lc)	SIPCOT industrial complex, Phase I & II
17	<b>Aurangabad (Maharashtra)</b> CEPI-77.44 (Ac Wc Ls)	MIDC Chikhalthana, MIDC Waluj, MIDC Shendra, and Paithan road industrial area
18	<b>Faridabad (Haryana)</b> CEPI-77.07 (Ac Ws Lc)	<ul style="list-style-type: none"> <li>• Sector 27-A, B, C, D</li> <li>• DLF phase- 1, sector 31,32</li> <li>• DLF phase- 2, sector 35</li> <li>• Sector 4, 6, 24, 27, 31, 59</li> <li>• Industrial area Hatin</li> <li>• Industrial model township</li> </ul>
19	<b>Agra (Uttar Pradesh)</b> CEPI-76.48 (As Wc Ls)	Nunihai industrial estate, Rambag nagar, UPSIDC industrial area, and Runukata industrial area
20	<b>Manali (Tamil Nadu)</b> CEPI-76.32 (Ac Ws Ls)	Manali industrial area
21	<b>Haldia (West Bengal)</b> CEPI-75.43 (As Wc Ls)	5 km wide strip (17.4 x 5.0 km) of industrial area on the southern side of the confluence point of Rivers Hugli and Rupnarayan, covering Haldia municipal area & Sutahata block – I and II
22	<b>Ahmedabad (Gujarat)</b> CEPI-75.28 (Ac Ws Ls)	<ul style="list-style-type: none"> <li>• GIDC Odhav</li> <li>• GIDC Naroda</li> </ul>
23	<b>Jodhpur (Rajasthan)</b> CEPI-75.19 (As Wc Ls)	<ul style="list-style-type: none"> <li>• Industrial areas including Basni areas (phase-I &amp; II), industrial estate, light &amp; heavy industrial areas, industrial areas behind new power house, Mandore, Bornada, Sangariya and village Tanwada &amp; Salawas.</li> <li>• Jodhpur city</li> </ul>
24	<b>Greater Cochin (Kerala)</b> CEPI-75.08 (As Wc Ls)	Eloor-Edayar industrial belt, Ambala Mogal industrial areas
25	<b>Mandi Gobind Garh (Punjab)</b> CEPI-75.08 (Ac Ws Lc)	Mandi Govindgarh municipal limit and khanna area
26	<b>Howrah (West Bengal)</b> CEPI-74.84 (As Ws Lc)	<ol style="list-style-type: none"> <li>Liluah-Bamangachhi region, Howrah</li> <li>Jalan industrial complex-1, Howrah</li> </ol>
27	<b>Vatva (Gujarat)</b> CEPI-74.77 (Ac Wc Ls)	GIDC Vatva, Narol industrial area (Villages Piplaj, Shahwadi, Narol)
28	<b>Ib Valley (Orissa)</b> CEPI-74.00 (Ac Ws Ls)	Ib Valley of Jharsuguda (Industrial and mining area)
29	<b>Varansi-Mirzapur (Uttar Pradesh)</b> CEPI-73.79 (As Wc Ls)	<ul style="list-style-type: none"> <li>• Industrial estate, Mirzapur</li> <li>• Chunar</li> <li>• Industrial estate, Chandpur, Varansi</li> <li>• UPSIC, industrial estate, Phoolpur</li> <li>• Industrial area, Ramnagar, Chandauli</li> </ul>
30	<b>Navi Mumbai (Maharashtra)</b> CEPI-73.77 (Ac Ws Ls)	TTC industrial area, MIDC, Navi Mumbai (including Bocks-D, C, EL, A, R, General, Kalva)
31	<b>Pali (Rajasthan)</b>	<ol style="list-style-type: none"> <li>Existing industrial areas: Mandia road, Puniyata road, Sumerpur</li> </ol>

	<b>CEPI-73.73 (As Wc Ls)</b>	b) Pali town
32	<b>Mangalore (Karnataka)</b> <b>CEPI-73.68 (Ac Ws Ls)</b>	Baikampady industrial area
33	<b>Jharsuguda (Orissa)</b> <b>CEPI-73.34 (Ac Ws Ls)</b>	Ib valley of Jharsuguda (Industrial and mining area)
34	<b>Coimbatore (Tamil Nadu)</b> <b>CEPI-72.38 (Ac Ws Ln)</b>	SIDCO, Kurichi industrial Clusters
35	<b>Bhadravati (Karnataka)</b> <b>CEPI-72.33 (Ac Ws Ln)</b>	KSSIDC Industrial area, Mysore paper mill & VISL township complex
36	<b>Tarapur (Maharashtra)</b> <b>CEPI-72.01 (Ac Ws Ls)</b>	MIDC Tarapur
37	<b>Panipat (Haryana)</b> <b>CEPI-71.91 (As Ws Ls)</b>	Panipat municipal limit and its industrial clusters
38	<b>Indore (Madhya Pradesh)</b> <b>CEPI-71.26 (As_Ws_Ls)</b>	Following 09 industrial area: <ul style="list-style-type: none"> <li>• Sanwer road</li> <li>• Shivaji nagar</li> <li>• Pologround</li> <li>• Laxmibai nagar</li> <li>• Scheme no.71</li> <li>• Navlakha</li> <li>• Pipliya</li> <li>• Palda</li> <li>• Rau</li> <li>• Inodre city</li> <li>• Other surrounding industrial areas: Manglia, Rajoda, Asrawad, Tejpur Gadwadi</li> </ul>
39	<b>Bhavnagar (Gujarat)</b> <b>CEPI-70.99 (As Ws Ls)</b>	GIDI Chitra, Bhavnagar
40	<b>Vishakhapatnam (Andhra Pradesh)</b> <b>CEPI-70.82 (As Ws Ls)</b>	Bowl area (the area between Yarada hill range in the south to Simhachalam hill range in the north and sea on the east and the present NH-5 in the west direction)
41	<b>Junagarh (Gujarat)</b> <b>CEPI-70.82 (As_Ws_Ls)</b>	Industrial areas: <ul style="list-style-type: none"> <li>• Sabalpur</li> <li>• Jay Bhavani</li> <li>• Jay Bhuvneshwari</li> <li>• GIDC Junagarh (I&amp;II)</li> </ul>
42	<b>Asansole (West Bengal)</b> <b>CEPI-70.20 (As Ws Ls)</b>	Bumpur area surrounding IISCO
43	<b>Patancheru - Bollaram (Andhra Pradesh)</b> <b>CEPI-70.07 (As Ws Ls)</b>	Industrial area: <ul style="list-style-type: none"> <li>• Patancheru</li> <li>• Bollaram</li> </ul>

Note:

Names of identified industrial clusters/potential impact zones are approximate location based on rapid survey and assessment and may alter partially subject to the detailed field study and monitoring. Detailed mapping will

be made available showing spatial boundaries of the identified industrial clusters including zone of influence/  
buffer zone, after in depth field study.

---

**ANNEXURE VI**  
**Pre-Feasibility Report: Points for Possible Coverage**

---

**Table 1: Points for Possible Coverage in Pre-feasibility Report**

S. No.	Contents	Points of Coverage in Pre-feasibility Report
I.	Executive summary	<ul style="list-style-type: none"> <li>▪ Details on prima facie idea of the project.</li> </ul>
II.	<b>Project Details</b>	
	Need/Justification of the Project	<ul style="list-style-type: none"> <li>▪ Current demand scenario of the product</li> <li>▪ Alternatives to meet the demand</li> <li>▪ Post project scenario on residual demand</li> </ul>
	Capacity of Distillery Industry	<ul style="list-style-type: none"> <li>▪ Production capacity of the industry</li> <li>▪ Sustainability of raw material supply and quality</li> <li>▪ Optimization of plant capacity</li> </ul>
	Process technology	<ul style="list-style-type: none"> <li>▪ Analysis of all available/advanced technologies, etc.</li> <li>▪ Analysis of various possible configurations for each technology or a combination of these technologies from available manufactures</li> <li>▪ Broad specifications for the distillery plants (s) including but not limited to: <ul style="list-style-type: none"> <li>- Plant outputs and process flow diagrams for each alternative</li> <li>- Electrical equipment, I&amp;C equipment, DCS equipment with redundancy</li> <li>- Balance of plant equipment</li> <li>- General plant layout</li> </ul> </li> </ul>
	Resources/raw materials	<ul style="list-style-type: none"> <li>▪ Details on raw material, by products/co-products</li> <li>▪ Water <ul style="list-style-type: none"> <li>- Water requirement for process, utilities, domestic, gardening etc.</li> <li>- Source of construction water and potable water</li> <li>- Source of circulating/consumptive water</li> <li>- Quality of raw water, treated water</li> <li>- Water budget calculations and effluent generation</li> <li>- Approved water allocation quota (drinking, irrigation and industrial use) and surplus availability</li> <li>- Feasible ways of bringing water to site indicating constraints if any.</li> <li>- Lean season water availability and allocation source in case main source not perennial.</li> </ul> </li> <li>▪ Manpower</li> <li>▪ Infrastructure</li> <li>▪ Electrical power</li> <li>▪ Construction material like sand, brick, stone chips, borrow earth etc.</li> </ul>
	Rejects (Pollution potential)	<ul style="list-style-type: none"> <li>▪ Air emissions</li> <li>▪ Water pollution</li> <li>▪ Solid / hazardous waste</li> <li>▪ Noise</li> <li>▪ Odour</li> </ul>
	Technical profile	<ul style="list-style-type: none"> <li>▪ Construction details <ul style="list-style-type: none"> <li>- Estimated duration</li> <li>- Number of construction workers including migrating workers</li> <li>- Construction equipment</li> <li>- Vehicular traffic</li> <li>- Source, mode of transportation and storage of construction</li> </ul> </li> </ul>

		<ul style="list-style-type: none"> <li>material</li> <li>▪ Traffic that would arise during different phases of the project and transportation mechanism to handle such traffic</li> <li>▪ New facilities needed</li> <li>▪ Technical parameters of the plant &amp; equipments to be used</li> <li>▪ Product storage and associated transportation system</li> <li>▪ Product demand &amp; supply position data on regional basis</li> </ul>
	Project schedule	<ul style="list-style-type: none"> <li>▪ Outline project implementation and procurement arrangement including contract packaging</li> <li>▪ Project implementation schedule showing various activities</li> </ul>
	Future prospects	<ul style="list-style-type: none"> <li>▪ Ascertain the costs and benefits of the proposed project for project life</li> <li>▪ Technical and logistic constraints/ requirements of project sustainability</li> </ul>
<b>III.</b>	<b>Selection of site based on least possible impacts</b>	
<b>i.</b>	<b>Choice of site selection</b>	
	Major techno-economic feasibility considerations	<ul style="list-style-type: none"> <li>▪ Land availability &amp; its development</li> <li>▪ Product demand around the selected site</li> <li>▪ Access to site for transportation of equipments/construction machinery, material, <i>etc.</i></li> <li>▪ Raw material, fuels; like Biomass (rice husk/ wood chips), spent wash concentrate availability and its transportation</li> <li>▪ Water availability and consumptive use</li> <li>▪ Product transportation</li> <li>▪ Infrastructure availability at selected site</li> <li>▪ Inter-state issue, if any</li> </ul>
	Incompatible landuse and ecologically sensitive attributes with respect to identified suitable sites	<ul style="list-style-type: none"> <li>▪ If any incompatible land-use attributes fall within the study area, the following details has to be provided: <ul style="list-style-type: none"> <li>- Public water supply areas from rivers/surface water bodies, from groundwater</li> <li>- Scenic areas/tourism areas/hill resorts</li> <li>- Religious places, pilgrim centers that attract over 10 lakh pilgrims a year</li> <li>- Protected tribal settlements (notified tribal areas where industrial activity is not permitted); CRZ</li> <li>- Monuments of national significance, World Heritage Sites</li> <li>- Cyclone, Tsunami prone areas (based on last 25 years);</li> <li>- Airport areas</li> <li>- Any other feature as specified by the State or local government and other features as locally applicable, including prime agricultural lands, pastures, migratory corridors, <i>etc.</i></li> </ul> </li> <li>▪ If ecologically sensitive attributes fall within the study area, please give details. Ecologically sensitive attributes include <ul style="list-style-type: none"> <li>- National parks</li> <li>- Wild life sanctuaries Game reserve</li> <li>- Tiger reserve/elephant reserve/turtle nesting ground</li> <li>- Breeding grounds</li> <li>- Core zone of biosphere reserve</li> <li>- Habitat for migratory birds</li> <li>- Mangrove area</li> <li>- Tropical forests</li> <li>- Important lakes</li> <li>- Endangered species of flora and fauna, <i>etc.</i></li> </ul> </li> </ul>
	Social aspects	<ul style="list-style-type: none"> <li>▪ Corporate responsibilities &amp; status of compliance</li> <li>▪ Employments and infrastructure added in the vicinity of the plant</li> </ul>

		<ul style="list-style-type: none"> <li>▪ Status of land availability, current and post project land use variation</li> <li>▪</li> </ul>
<b>ii.</b>	<b>Details of selected site</b>	
	Land details	<ul style="list-style-type: none"> <li>▪ Land requirement and availability</li> <li>▪ Land ownership details such as Government, private, tribal, non-tribal, etc.</li> <li>▪ Total area of the project/site</li> <li>▪ Prevailing land cost details</li> </ul>
	Location	<ul style="list-style-type: none"> <li>▪ Geographical details - Longitude &amp; latitude, village, taluka, district, state</li> <li>▪ Approach to site – roads, railways and airports</li> <li>▪ Distance from nearest residential and industrial areas</li> <li>▪ Distance from nearest water bodies such as river, canal, dam, etc</li> <li>▪ Distance from ecologically sensitive areas</li> <li>▪ In case of flood prone areas, HFL of the site</li> <li>▪ In case of seismic areas, seismic zone, active faults, occurrence on earthquakes, etc.</li> <li>▪ Proximity from infrastructural facilities</li> </ul>
	Physical characteristics	<ul style="list-style-type: none"> <li>▪ Demography</li> <li>▪ Meteorological data</li> <li>▪ Landuse pattern such as agricultural, barren, forest, <i>etc.</i> and details thereof</li> <li>▪ Topography of the area</li> <li>▪ Drainage patterns</li> <li>▪ Soil condition and soil investigation results</li> <li>▪ Ground profile and levels</li> </ul>
<b>IV.</b>	<b>Anticipated impacts based on project operations on receiving environment</b>	<ul style="list-style-type: none"> <li>▪ Population</li> <li>▪ Flora and fauna</li> <li>▪ Water</li> <li>▪ Soil</li> <li>▪ Air</li> <li>▪ Climate</li> <li>▪ Landscape, <i>etc.</i></li> </ul>
<b>V.</b>	<b>Proposed broad mitigation measures which could effectively be internalized as project components to have environmental and social acceptance of the proposed site</b>	<ul style="list-style-type: none"> <li>▪ Preventive measures</li> <li>▪ Source control measures</li> <li>▪ Mitigation measures at the receiving environment, <i>etc.</i></li> </ul>
<b>VI.</b>	<b>An indication of any difficulties (technical deficiencies or lack of know-how) encountered by the developer in compiling the required information.</b>	

The above listing is not exhaustive. Thus the proponent may provide additional necessary information, felt appropriate, to include in the pre-feasibility study report in support of selecting the site for the proposed developmental activities. The Concerned EAC/SEAC during scrutiny, may specifically ask for any additional information/data required to substantiate the requirement to prescribe the ToR for EIA studies. However, it is to make clear that all the required further information by EAC/SEAC may be mentioned in one single letter, within the prescribed time.



---

**ANNEXURE VII**  
**TYPES OF MONITORING AND NETWORK DESIGN**  
**CONSIDERATIONS**

---

## TYPES OF MONITORING AND NETWORK DESIGN CONSIDERATIONS

### A. Types of Monitoring

Monitoring refers to the collection of data using a series of repetitive measurements of environmental parameters (or, more generally, to a process of systematic observation). The environmental quality monitoring programme design will be dependent upon the monitoring objectives specified for the selected area of interest. The main types of EIA monitoring activities are:

- Baseline monitoring is the measurement of environmental parameters during the pre-project period for the purpose of determining the range of variation of the system and establishing reference points against which changes can be measured. This leads to the assessment of the possible (additional available) assimilative capacity of the environmental components in pre-project period w.r.t. the standard or target level.
- Effects monitoring is the measurement of environmental parameters during project construction and implementation to detect changes which are attributable to the project to provide the necessary information to:
  - verify the accuracy of EIA predictions; and
  - determine the effectiveness of measures to mitigate adverse effects of projects on the environment.
  - Feedback from environmental effect monitoring programs may be used to improve the predictive capability of EIAs and also determine whether more or less stringent mitigation measures are needed
- Compliance monitoring is the periodic sampling or continuous measurement of environmental parameters to ensure that regulatory requirements and standards are being met.

Compliance and effects monitoring occurs during the project construction, operation, and abandonment stages. The resources and institutional set-up should be available for the monitoring at these stages. All large-scale construction projects will require some construction stage monitoring. To control the environmental hazards of construction as specified in the EIA, a monitoring program should be established to ensure that each mitigation measure is effectively implemented. There are numerous potential areas for monitoring during operations.

The scope of monitoring topics discussed in this chapter is limited to Baseline and Effects monitoring. In addition, this chapter will also discuss the Compliance monitoring during the construction phase. Post-project monitoring requirements are discussed in the EMP.

Before any field monitoring tasks are undertaken there are many institutional, scientific, and fiscal issues that must be addressed in the implementation of an environmental monitoring program. Careful consideration of these issues in the design and planning stages will help avoid many of the pitfalls associated with environmental monitoring programs. Although these issues are important but the discussions here are confined to the monitoring network design component.

## **B. Network Design**

### **Analysis of Significant Environmental Issues**

At the outset of planning for an environmental monitoring network, the EIA manager may not know exactly what should be monitored, when monitoring should begin, where it should monitor, which techniques should be employed, and who should take responsibility for its conduct. Because there are usually a number of objective decisions associated with network design to be made, it is important to start with an analysis of environmental issues. The scoping phase of an EIA is designed to identify and focus on the major issues. Scoping should provide a valuable source of information on the concerns that need to be addressed by the monitoring network design. These are project specific as well as specific to the environmental setting of the location where the project is proposed to be located

Hence, the network designs are associated with questions like:

- What are the expected outputs of the monitoring activity?
- Which problems do we need to address to? *etc.*

Defining the output will influence the design of the network and optimize the resources used for monitoring. It will also ensure that the network is specially designed to optimize the information on the problems at hand

### **What to Monitor?**

The question of what to monitor is associated with the identification of VECs.

VECs are generally defined as environmental attributes or components of the environment that are valued by society as identified during the scoping stage of the project. They are determined on the basis of perceived public concerns. For example, changes to water quality and quantity could have implications on fish by affecting habitat, food supply, oxygen, and contaminant uptake. Similarly, employment and business, and economies are both VECs that serve as pathways.

The choice of VECs is also related to the perceived significant impact of the project implementation on important environmental components. In general, the significance or importance of environmental components is judged based on:

- legal protection provided (for example, rare and endangered species)
- political or public concerns (for example, resource use conflicts and sustainable development)
- scientific judgment (for example, ecological importance); or
- commercial or economic importance

However, in addition to their economic, social, political or ecological significance, the chosen VEC should also have unambiguous operational ease, be accessible to prediction and measurement; and be susceptible to hazard. Once the VECs are defined, the VECs may be directly measured (for example, extent of habitat for an endangered species). In cases where it is impossible or impractical to directly measure the VECs, the chosen measurement endpoints or environmental indicators must correspond to, or be predictive of assessment endpoints.

The chosen environmental indicators must be: 1) measurable; 2) appropriate to the scale of disturbance/ contamination; 3) appropriate to the impact mechanism; 4) appropriate

and proportional to temporal dynamics; 5) diagnostic; and 6) standardized; as well as have: 1) a low natural variability; 2) a broad applicability; and 3) an existing data series.

### **Where, How and How Many Times to Monitor?**

These are the other components of Monitoring Network Design. These questions are best answered based on local field conditions, capacity and resources available, prevailing legal and regulatory priorities, *etc.* For this screening or reconnaissance Surveys of the study area also necessary. This may also include some simple inexpensive measurements and assimilative/dispersion modeling. The data will give some information on the prevailing special and temporal variations, and the general background air pollution in the area. The number of monitoring stations and the indicators to be measured at each station in the final permanent network may then be decided upon based on the results of the screening study as well as on the knowledge of the sources of the proposed development and prevailing local environmental/meteorological conditions. The best possible definition of the air pollution problem, together with the analysis of the resources: personnel, budget and equipment available, represent the basis for the decision on the following questions:

- What spatial density (number) of sampling stations is required? How many samples are needed and during what period (sampling (averaging) time and frequency)?
- Where should the stations be located?
- What kind of equipment should be used?
- What additional background information is needed?
  - meteorology
  - topography
  - population density
  - emission sources and emission rates
  - effects and impacts
- How will the data be made available/communicated?

### **C. Site Selection**

This normally means that for designing a monitoring programme in an (study) area which might have an impact, several monitoring stations are needed for characterizing the baseline conditions of the impacted area. When considering the location of individual samplers, it is essential that the data collected are representative for the location and type of area without the undue influence from the immediate surroundings. In any measurement point in the study area the total ambient concentration is the representative of:

- natural background concentration
- regional background
- impact of existing large regional sources such as Industrial emissions and other power plants

To obtain the information about the importance of these different contributions it is therefore necessary to locate monitoring stations so that they are representative for different impacts. In addition to the ambient pollution data, one would often need other data governing the variations such as meteorological data for air pollution, to identify and quantify the sources contributing to the measurements.. When considering the location of individual samplers, it is essential that the data collected are representative for the location and type of area without undue influence from the immediate surroundings.

---

**ANNEXURE VIII**  
**Guidance for Assessment of Baseline Components and Attributes**

---

**GUIDANCE FOR ASSESSMENT OF BASELINE COMPONENTS AND ATTRIBUTES\***

Attributes	Sampling		Method of Measurement	Remarks
	Network	Frequency		
<b>A. Land Environment</b>				
<ul style="list-style-type: none"> <li>▪ Soil</li> <li>▪ Particle size distribution</li> <li>▪ Texture</li> <li>▪ pH</li> <li>▪ Electrical conductivity</li> <li>▪ Cation exchange capacity</li> <li>▪ Alkali metals</li> <li>▪ Sodium Absorption Ratio (SAR)</li> <li>▪ Permeability</li> <li>▪ Porosity</li> </ul>	One surface sample from each landfill and/or hazardous waste site (if applicable) and prime villages, (soil samples be collected as per BIS specifications) in the study area	Season-wise	Collected and analyzed as per soil analysis reference book, M.I.Jackson and soil analysis reference book by C.A. Black	The purpose of impact assessment on soil (land environment) is to assess the significant impacts due to leaching of wastes or accidental releases and contaminating
<b>B. Land Use/Landscape</b>				
<ul style="list-style-type: none"> <li>▪ Location code</li> <li>▪ Total project area</li> <li>▪ Topography</li> <li>▪ Drainage (natural)</li> <li>▪ Cultivated, forest plantations, water bodies, roads and settlements</li> </ul>	At least 20 points along with plant boundary and general major land use categories in the study area.	Drainage once in the study period and land use categories from secondary data (local maps) and satellite imageries	<ul style="list-style-type: none"> <li>▪ Global positioning system</li> <li>▪ Topo-sheets</li> <li>▪ Satellite Imageries</li> <li>▪ (1:25,000)</li> <li>▪ Satellite Imageries</li> <li>▪ (1:25,000)</li> </ul>	Drainage within the plant area and surrounding is very important for storm water impacts.  From land use maps sensitive receptors (forests, parks, mangroves <i>etc.</i> ) can be identified
<b>C. Solid Waste</b>				
Quantity: <ul style="list-style-type: none"> <li>▪ Based on waste generated</li> </ul>	For green field unites it is based on	Process wise or activity wise for	Guidelines	

Attributes	Sampling		Method of Measurement	Remarks
	Network	Frequency		
from per unit production <ul style="list-style-type: none"> <li>▪ Per capita contribution</li> <li>▪ Collection, transport and disposal system</li> <li>▪ Process Waste</li> <li>▪ Quality (oily, chemical, biological)</li> </ul>	secondary data base of earlier plants.	respective raw material used. Domestic waste depends upon the season also	IS 9569 : 1980 IS 10447 : 1983 IS 12625 : 1989 IS 12647 : 1989 IS 12662 (PTI) 1989	
<ul style="list-style-type: none"> <li>▪ General segregation into biological/organic/inert/hazardous</li> <li>▪ Loss on heating</li> <li>▪ pH</li> <li>▪ Electrical Conductivity</li> <li>▪ Calorific value, metals <i>etc.</i></li> </ul>	Grab and Composite samples	Process wise or activity wise for respective raw material used. Domestic waste depends upon the season also	Analysis IS 9334 : 1979 IS 9235 : 1979 IS 10158 : 1982	
Quality: <ul style="list-style-type: none"> <li>▪ Permeability And porosity</li> <li>▪ Moisture pH</li> <li>▪ Electrical conductivity</li> <li>▪ Loss on ignition</li> <li>▪ Phosphorous</li> <li>▪ Total nitrogen</li> <li>▪ Cation exchange capacity</li> <li>▪ Particle size distribution</li> <li>▪ Heavy metal</li> <li>▪ Ansonia</li> <li>▪ Flouride</li> </ul>	Grab and Composite samples. Recyclable components have to analyzed for the recycling requirements	Process wise or activity wise for respective raw material used.	Analysis IS 9334 : 1979 IS 9235 : 1979 IS 10158 : 1982	Impacts of hazardous waste should be performed critically depending on the waste characteristics and place of discharge. For land disposal the guidelines should be followed and impacts of accidental releases should be assessed
<b>D. Biological Environment (aquatic)</b>				
<ul style="list-style-type: none"> <li>▪ Primary productivity</li> </ul>	Considering probable	Season changes are	Standards techniques	Seasonal sampling for

Attributes	Sampling		Method of Measurement	Remarks
	Network	Frequency		
<ul style="list-style-type: none"> <li>▪ Aquatic weeds</li> <li>▪ Enumeration of phytoplankton, zooplankton and benthos</li> <li>▪ Fisheries</li> <li>▪ Diversity indices</li> <li>▪ Trophic levels</li> <li>▪ Rare and endangered species</li> <li>▪ Sanctuaries / closed areas / Coastal regulation zone (CRZ)</li> <li>▪ Terrestrial</li> <li>▪ Vegetation – species, list, economic importance, forest produce, medicinal value</li> <li>▪ Importance value index (IVI) of trees</li> <li>▪ Wild animals</li> </ul>	<p>impact, sampling points and number of samples to be decided on established guidelines on ecological studies based on site eco-environment setting within 10/25 km radius from the proposed site</p> <p>Samples to collect from upstream and downstream of discharge point, nearby tributaries at down stream, and also from dug wells close to activity site</p>	very important	(APHA et. Al. 1995, Rau and Wooten 1980) to be followed for sampling and measurement	<p>aquatic biota</p> <p>One season for terrestrial biota, in addition to vegetation studies during monsoon season</p> <p>Preliminary assessment</p> <p>Microscopic analysis of plankton and meiobenthos, studies of macrofauna, aquatic vegetation and application of indices, viz. Shannon, similarity, dominance IVI <i>etc</i></p> <p>Point quarter plot-less method (random sampling) for terrestrial vegetation survey.</p>
<ul style="list-style-type: none"> <li>▪ Avifauna</li> <li>▪ Rare and endangered species</li> <li>▪ Sanctuaries / National park / Biosphere reserve</li> </ul>	For forest studies, chronic as well as short-term impacts should be analyzed warranting data on micro climate conditions			<p>Secondary data to collect from Government offices, NGOs, published literature</p> <p>Plankton net</p> <p>Sediment dredge</p> <p>Depth sampler</p> <p>Microscope</p>



Attributes	Sampling		Method of Measurement	Remarks
	Network	Frequency		
				Field binocular
<b>E. Socio-economic</b>				
<ul style="list-style-type: none"> <li>▪ Demographic structure</li> <li>▪ Infrastructure resource base</li> <li>▪ Economic resource base</li> <li>▪ Health status: Morbidity pattern</li> <li>▪ Cultural and aesthetic attributes</li> </ul>	Socio-economic survey is based on proportionate, stratified and random sampling method	Different impacts occurs during construction and operational phases of the project	Primary data collection through R&R surveys (if require) or community survey are based on personal interviews and questionnaire	Secondary data from census records, statistical hard books, toposheets, health records and relevant official records available with Govt. agencies

\* Project Specific concerned parameters needs to be identified by the project proponent and shall be incorporated in the draft ToR, to be submitted to the Authority for the consideration and approval by the EAC/SEAC.

---

**ANNEXURE IX**  
**Sources of Secondary Data**

---

## **Annexure VIIA: Potential Sources of Data For EIA**

Information	Source
<b>Air Environment</b>	
1. Meteorology- Temperature, Rainfall, Humidity, Inversion, Seasonal Wind rose pattern (16 point compass scale), cloud cover, wind speed, wind direction, stability, mixing depth	<ul style="list-style-type: none"> <li>⊗ Indian Meteorology Department, Pune</li> </ul>
2. Ambient Air Quality- 24 hourly concentration of SPM, RPM, SO <sub>2</sub> , NO <sub>x</sub> , CO	<ul style="list-style-type: none"> <li>⊗ Central Pollution Control Board (CPCB),</li> <li>⊗ State Pollution Control Board (SPCB),</li> <li>⊗ Municipal Corporations</li> <li>⊗ Ministry of Environment and Forests (MoEF)</li> <li>⊗ State Department of Environment (DoEN)</li> </ul>
<b>Water Environment</b>	
3. Surface water- water sources, water flow (lean season), water quality, water usage, Downstream water users Command area development plan Catchment treatment plan	<ul style="list-style-type: none"> <li>⊗ Central Water Commission (CWC),</li> <li>⊗ Central Pollution Control Board (CPCB),</li> <li>⊗ State Pollution Control Board (SPCB), Central Water and Power Research Institute (CWPRS), Pune</li> <li>⊗ State Irrigation Department</li> <li>⊗ Hydel Power generation organizations such as NHPC, State SEBs</li> </ul>
4. Ground Water- groundwater recharge rate/withdrawal rate, ground water potential groundwater levels (pre monsoon, post monsoon), ground water quality, changes observed in quality and quantity of ground water in last 15 years	<ul style="list-style-type: none"> <li>⊗ Central Ground Water Board (CGWB)</li> <li>⊗ Central Ground Water Authority (CGWA)</li> <li>⊗ State Ground Water Board (SGWB)</li> <li>⊗ National Water Development Authority (NWDA)</li> </ul>
5. Coastal waters- water quality, tide and current data, bathymetry	<ul style="list-style-type: none"> <li>⊗ Department of Ocean Development, New Delhi</li> <li>⊗ State Maritime Boards</li> <li>⊗ Naval Hydrographer's Office, Dehradun</li> <li>⊗ Port Authorities</li> <li>⊗ National Institute of Oceanography (NIO), Goa</li> </ul>
<b>Biological Environment</b>	
6. Description of Biological Environment- inventory of flora and fauna in 7 km radius, endemic species, endangered species, Aquatic Fauna, Forest land, forest type and density of vegetation, biosphere, national parks, wild life sanctuaries, tiger reserve, elephant reserve, turtle nesting ground, core zone of biosphere reserve, habitat of migratory birds, routes of migratory birds	<ul style="list-style-type: none"> <li>⊗ District Gazetteers</li> <li>⊗ National Remote Sensing Agency (NRSA), Hyderabad</li> <li>⊗ Forest Survey of India, Dehradun</li> <li>⊗ Wildlife Institute of India</li> <li>⊗ World Wildlife Fund</li> <li>⊗ Zoological Survey of India</li> <li>⊗ Botanical Survey of India</li> <li>⊗ Bombay Natural History Society, (BNHS), Mumbai</li> <li>⊗ State Forest Departments</li> <li>⊗ State Fisheries Department</li> <li>⊗ Ministry of Environment and Forests</li> <li>⊗ State Agriculture Departments</li> <li>⊗ State Agriculture Universities</li> </ul>
<b>Land Environment</b>	
7. Geographical Information-Latitude, Longitude, Elevation ( above MSL)	<ul style="list-style-type: none"> <li>⊗ Toposheets of Survey of India, Pune</li> <li>⊗ National Remote Sensing Agency (NRSA), Hyderabad</li> <li>⊗ Space Application Centre (SAC), Ahmedabad</li> </ul>

Information	Source
8. Nature of Terrain, topography map indicating contours (1:2500 scale)	<ul style="list-style-type: none"> <li>⊙ Survey of India Toposheets</li> <li>⊙ National Remote Sensing Agency (NRSA), Hyderabad</li> <li>⊙ State Remote Sensing Centre,</li> <li>⊙ Space Application Centre (SAC), Ahmedabad</li> </ul>
9. Hydrogeology- Hydrogeological report (in case of ground water is used/area is drought prone/wastewater is likely to discharged on land) Geomorphological analysis (topography and drainage pattern) Geological analysis (Geological Formations/Disturbances- geological and structural maps, geomorphological contour maps, structural features, including lineaments, fractures, faults and joints) Hydrogeological analysis (disposition of permeable formations, surface-ground water links, hydraulic parameter determination etc) Analysis of the natural soil and water to assess pollutant absorption capacity	<ul style="list-style-type: none"> <li>⊙ NRSA, Hyderabad</li> <li>⊙ Survey of India Toposheets</li> <li>⊙ Geological Survey of India</li> <li>⊙ State Geology Departments</li> <li>⊙ State Irrigation Department</li> <li>⊙ Department of Wasteland Development, Ministry of Rural Areas</li> <li>⊙ National Water Development Authority (NWDA)</li> </ul>
10. Nature of Soil, permeability, erodibility classification of the land	<ul style="list-style-type: none"> <li>⊙ Agriculture Universities</li> <li>⊙ State Agriculture Department</li> <li>⊙ Indian Council for Agriculture Research</li> <li>⊙ State Soil Conservation Departments</li> <li>⊙ National Bureau of Soil Survey and Landuse Planning</li> <li>⊙ Central Arid Zone Research Institute (CAZRI), Jodhpur</li> </ul>
11. Landuse in the project area and 10 km radius of the periphery of the project	<ul style="list-style-type: none"> <li>⊙ Survey of India- Toposheets</li> <li>⊙ All India Soil and Landuse Survey; Delhi</li> <li>⊙ National Remote Sensing Agency (NRSA), Hyderabad</li> <li>⊙ Town and County Planning Organisation</li> <li>⊙ State Urban Planning Department</li> <li>⊙ Regional Planning Authorities (existing and proposed plans)</li> <li>⊙ Village Revenue Map- District Collectorate</li> <li>⊙ Directorate of Economics and Statistics-State Government</li> <li>⊙ Space Application Centre, Ahmedabad</li> </ul>
12. Coastal Regulation Zones- CRZMP, CRZ classification, Demarcation of HTL and LTL*	<ul style="list-style-type: none"> <li>⊙ Urban Development Department</li> <li>⊙ State Department of Environment</li> <li>⊙ State Pollution Control Board</li> <li>⊙ Space Application Centre*</li> <li>⊙ Centre for Earth Sciences Studies, Thiruvanthapuram*</li> <li>⊙ Institute of Remote Sensing, Anna University Chennai*</li> <li>⊙ Naval Hydrographer's Office, Dehradun*</li> <li>⊙ National Institute of Oceanography, Goa*</li> <li>⊙ National Institute of Ocean Technology, Chennai</li> <li>⊙ Centre for Earth Science Studies</li> </ul>

\* Agencies authorized for approval of demarcation of HTL and LTL

Information	Source
<b>Social</b>	
13. Socioeconomic - population, number of houses and present occupation pattern within 7 km from the periphery of the project	<ul style="list-style-type: none"> <li>⊗ Census Department</li> <li>⊗ District Gazetteers- State Government</li> <li>⊗ District Statistics- District Collectorate</li> <li>⊗ International Institute of Population Sciences, Mumbai (limited data)</li> <li>⊗ Central Statistical Organisation</li> </ul>
14. Monuments and heritage sites	<ul style="list-style-type: none"> <li>District Gazetteer</li> <li>Archeological Survey of India,</li> <li>INTACH</li> <li>District Collectorate</li> <li>Central and State Tourism Department</li> <li>State Tribal and Social Welfare Department</li> </ul>
<b>Natural Disasters</b>	
15. Seismic data (Mining Projects)- zone no, no of earthquakes and scale, impacts on life, property existing mines	<ul style="list-style-type: none"> <li>⊗ Indian Meteorology Department, Pune</li> <li>⊗ Geological Survey of India</li> </ul>
16. Landslide prone zone, geomorphological conditions, degree of susceptibility to mass movement, major landslide history (frequency of occurrence/decade), area affected, population affected	<ul style="list-style-type: none"> <li>⊗ Space Application Centre</li> </ul>
17. Flood/cyclone/droughts- frequency of occurrence per decade, area affected, population affected	<ul style="list-style-type: none"> <li>⊗ Natural Disaster Management Division in Department of Agriculture and Cooperation</li> <li>⊗ Indian Meteorological Department</li> </ul>
<b>Industrial</b>	
18. Industrial Estates/Clusters, Growth Centres	<ul style="list-style-type: none"> <li>⊗ State Industrial Corporation</li> <li>⊗ Industrial Associations</li> <li>⊗ State Pollution Control Boards</li> <li>⊗ Confederation Indian Industries (CII)</li> <li>⊗ FICCI</li> </ul>
19. Physical and Chemical properties of raw material and chemicals (Industrial projects); fuel quality	<ul style="list-style-type: none"> <li>⊗ Material and Safety Data Sheets</li> <li>⊗ ENVIS database of Industrial Toxicological Research Centre, Lucknow</li> <li>⊗ Indian Institute Petroleum</li> </ul>
20. Occupational Health and Industrial Hygiene-major occupational health and safety hazards, health and safety requirements, accident histories	<ul style="list-style-type: none"> <li>⊗ Central Labour Institute, Mumbai</li> <li>⊗ Directorate of Industrial Safety</li> <li>⊗ ENVIS Database of Industrial Toxicological Research Centre, Lucknow</li> <li>⊗ National Institute of Occupational Health, Ahmedabad</li> </ul>
21. Pollutant release inventories (Existing pollution sources in area within 10 km radius)	<ul style="list-style-type: none"> <li>⊗ Project proponents which have received EC and have commenced operations</li> </ul>
22. Water requirement (process, cooling water, DM water, Dust suppression, drinking, green belt, fire service)	<ul style="list-style-type: none"> <li>⊗ EIA Reports</li> <li>⊗ National and International Benchmarks</li> </ul>

## Annexure VIIB: Summary of Available Data with Potential Data Sources for EIA

Agency	Information Available
1. Archaeological Survey of India Department of Culture Government of India Janpath, New Delhi - 110011 <a href="mailto:Asi@del3.vsnl.net.in">Asi@del3.vsnl.net.in</a>	<ul style="list-style-type: none"> <li>⊙ Inventory of monuments and sites of national importance- Listing and documentation of monuments according to world heritage, pre historic, proto historic and secular, religious places and forts</li> </ul>
2. Botanical Survey Of India P-8, Brabourne Road Calcutta 700001 Tel#033 2424922 Fax#033 2429330 Email: <a href="mailto:envis@cal2.vsnl.net.in">envis@cal2.vsnl.net.in</a> .  RO - Coimbatore, Pune, Jodhpur, Dehradun, Allahabad, Gantok, Itanagar, Port Blair	<ul style="list-style-type: none"> <li>⊙ Photodiversity documentation of flora at National, State and District level and flora of protected areas, hotspots, fragile ecosystems, sacred groves etc</li> <li>⊙ Identification of threatened species including endemics, their mapping, population studies</li> <li>⊙ Database related to medicinal plants, rare and threatened plant species</li> <li>⊙ Red data book of Indian plants (Vol 1,2, and 3)</li> <li>⊙ Manual for roadside and avenue plantation in India</li> </ul>
3. Bureau of Indian Standards Manak Bhawan, 9 Bahadur Shah Zafar Marg, New Delhi 110 002 Tel#3230131, 3233375, 3239402 (10 lines) Fax : 91 11 3234062, 3239399, 3239382 Email- <a href="mailto:bis@vsnal.com">bis@vsnal.com</a>	<ul style="list-style-type: none"> <li>⊙ Bureau of Indian Standards Committees on Earthquake Engineering and Wind Engineering have a Seismic Zoning Map and the Wind Velocity Map including cyclonic winds for the country</li> </ul>
4. Central Water Commission (CWC) Sewa Bhawan, R.K.Puram New Delhi - 110066 <a href="mailto:cmanoff@niccwc.delhi.nic.in">cmanoff@niccwc.delhi.nic.in</a>  RO- Bangalore, Bhopal, Bhubaneshwar, Chandigarh, Coimbatore/Chennai, Delhi, Hyderabad, Lucknow, Nagpur, Patna, Shillong, Siliguri and Vadodara	<ul style="list-style-type: none"> <li>⊙ Central Data Bank -Collection, collation and Publishing of Hydrological, Hydrometeorological, Sediment and Water Quality data-</li> <li>⊙ Basin wise Master Plans</li> <li>⊙ Flood atlas for India</li> <li>⊙ Flood Management and Development and Operation of Flood Forecasting System- CWC operate a network of forecasting stations Over 6000 forecasts are issued every year with about 95% of the forecasts within the permissible limit.</li> <li>⊙ Water Year Books, Sediment Year Books and Water Quality Year Books.</li> <li>⊙ Also actively involved in monitoring of 84 identified projects through National, State and Project level Environmental Committees for ensuring implementation of environmental safeguards</li> </ul>
5. Central Ground Water Board (HO) N.H.IV, New CGO Complex, Faridabad - 121001 RO - Guwahati, Chandigarh, Ahemadabad, Trivandrum, Calcutta, Bhopal, Lucknow, Banglore, Nagpur, Jammu, Bhubneshwar, Raipur, Jaipur, Chennai, Hyderabad, Patna	<ul style="list-style-type: none"> <li>⊙ surveys, exploration, monitoring of ground water development</li> </ul>

<sup>16</sup> Based on web search and literature review

6.	Central Pollution Control Board Parivesh Bhawan, CBD-cum-Office Complex East Arjun Nagar, DELHI - 110 032 INDIA E-mail : <a href="mailto:cpcb@alpha.nic.in">cpcb@alpha.nic.in</a>	<ul style="list-style-type: none"> <li>⊗ National Air Quality Monitoring Programme</li> <li>⊗ National River Water Quality Monitoring Programme- Global Environment Monitoring , MINARS</li> <li>⊗ Zoning Atlas Programme</li> <li>⊗ Information on 17 polluting category industries (inventory, category wise distribution, compliance, implementation of pollution control programmes)</li> </ul>
7.	Central Arid Zone Research Institute, Jodhpur Email : <a href="mailto:cazri@x400.nicgw.nic.in">cazri@x400.nicgw.nic.in</a>  Regional Centre at Bhuj in Gujarat	<ul style="list-style-type: none"> <li>⊗ AGRIS database on all aspects of agriculture from 1975 to date</li> <li>⊗ Also have cell on Agriculture Research Information System;</li> <li>⊗ Working on ENVIS project on desertification</li> <li>⊗ Repository of information on the state of natural resources and desertification processes and their control</li> <li>⊗ The spectrum of activities involves researches on basic resource inventories; monitoring of desertification, rehabilitation and management of degraded lands and other areas</li> </ul>
8.	Central Inland Capture Fisheries Research Institute, Barrackpore- 743101, Tel#033-5600177 Fax#033-5600388 Email : <a href="mailto:cicfri@x400.nicgw.nic.in">cicfri@x400.nicgw.nic.in</a>	<ul style="list-style-type: none"> <li>⊗ Data Base on Ecology and fisheries of major river systems of India. Biological features of commercially important riverine and estuarine fish species. Production functions and their interactions in floodplain wetlands.</li> <li>⊗ Activities - Environmental Impact Assessment for Resource Management ; Fisheries Resource surveys</li> </ul>
9.	Central Institute of Brackish Water Aquaculture 141, Marshalls Road, Egmore , Chennai - 600 008, Tel# 044-8554866, 8554891, Director (Per) 8554851 Fax#8554851,	<ul style="list-style-type: none"> <li>⊗ Repository of information on brackish water fishery resources with systematic database of coastal fishery resources for ARIS</li> <li>⊗ Agricultural Research Information System (ARIS) database covers State wise data on soil and water quality parameters, land use pattern, production and productivity trends,</li> <li>⊗ Social, economic and environmental impacts of aquaculture farming,</li> <li>⊗ Guidelines and effluent standards for aquaculture farming</li> </ul>
10.	Central Marine Fisheries Research Institute (CMFRI), Cochin	<ul style="list-style-type: none"> <li>⊗ Assessing and monitoring of exploited and un-exploited fish stocks in Indian EEZ</li> <li>⊗ Monitoring the health of the coastal ecosystems, particularly the endangered ecosystems in relation to artisanal fishing, mechanised fishing and marine pollution</li> <li>⊗ The institute has been collecting data on the catch and effort and biological characteristics for nearly half a century based on scientifically developed sampling scheme, covering all the maritime States of the country</li> <li>⊗ The voluminous data available with the institute is managed by the National Marine Living Resources Data Centre (NMLRDC)</li> </ul>
11.	Central Water and Power Research Station, Pune Tel#020-4391801-14; 4392511; 4392825  Fax #020-4392004,4390189	<ul style="list-style-type: none"> <li>⊗ Numerical and Physical models for hydro-dynamic simulations</li> </ul>
12.	Central Institute of Road Transport, Bhosari, Pune 411 026, India. Tel : +91 (20) 7125177, 7125292, 7125493, 7125494	<ul style="list-style-type: none"> <li>⊗ Repository of data on all aspects of performance of STUs and a host of other related road transport parameters</li> </ul>

13. Department of Ocean Development	<ul style="list-style-type: none"> <li>⑨ Assessment of environment parameters and marine living resources (primary and secondary) in Indian EEZ (Nodal Agency NIO Kochi)</li> <li>⑨ Stock assessment, biology and resource mapping of deep sea shrimps, lobsters and fishes in Indian EEZ (Nodal agency-Fisheries Survey of India)</li> <li>⑨ Investigations of toxical algal blooms and benthic productivity in Indian EEZ (Nodal agency- Cochin University of Science and technology)</li> <li>⑨ Coastal Ocean Monitoring and Prediction System (COMAP) - monitoring and modelling of marine pollution along entire Indian coast and islands. Parameters monitored are temp, salinity, DO, pH, SS, BOD, inorganic phosphate, nitrate, nitrite, ammonia, total phosphorus, total nitrite, total organic carbon, petroleum hydrocarbons, pathogenic vibrios, pathogenic E.coli, shigella, salmonella, heavy metals (Cd, Hg, Pb) and pesticide residues (DDT, BHC, Endosulfan). Monitoring is carried out along the ecologically sensitive zones and urban areas (NIO Mumbai- Apex coordinating agency).</li> <li>⑨ Sea Level Measurement Programme (SELMAM)- sea level measurement at selected stations (Porbandar, Bombay, Goa, Cochin, Tuticorin, Madras, Machilipatnam, Visakhapatnam, Paradeep, Calcutta and Kavaratti (Lakshadweep Island)) along Indian coast and islands using modern tide gauges</li> <li>⑨ Detailed coastal maps through Survey of India showing contour at 1/2 a metre interval in the scale of 1:25000. (Nellore- Machhalipatnam work already over)</li> <li>⑨ Marine Data Centre (MDC) IMD for Ocean surface meteorology, GSI for marine geology, SOI for tide levels, Naval Hydrographic Office for bathymetry, NIO Goa for physical chemical and biological oceanography, NIO Mumbai for marine pollution, CMFRI for coastal fisheries, Institute of Ocean Management Madras for coastal geomorphology</li> <li>⑨ DOD has setup Indian National Centre for Ocean Information Services (INCOIS) at Hyderabad for generation and dissemination of ocean data products (near real time data products such as sea surface temperature, potential fishing zones, upwelling zones, maps, eddies, chlorophyll, suspended sediment load etc). MDC will be integrated with INCOIS</li> <li>⑨ Integrated Coastal and Marine Area Management (ICMAM) programme - GIS based information system for management of 11 critical habitats namely Pichavaram, Karwar, Gulf of Mannar, Gulf of Khambat, Gulf of Kutch, Malvan, Cochin, Coringa mangroves, Gahirmata, Sunderbans and Kadamat (Lakshadweep)</li> <li>⑨ Wetland maps for Tamil Nadu and Kerala showing the locations of lagoons, backwaters, estuaries, mudflats etc (1:50000 scale)</li> <li>⑨ Coral Reef Maps for Gulf of Kachch, Gulf of Mannar, Andaman and Nicobar and Lakshadweep Islands (1:50,000 scale) indicating the condition of corals, density etc</li> </ul>
14. Environment Protection Training and Research Institute Gachibowli, Hyderabad - 500 019, India Phone: +91-40-3001241, 3001242, 3000489 Fax: +91-40- 3000361 E-mail: info@eptri.com	<ul style="list-style-type: none"> <li>⑨ Environment Information Centre- has appointed EPTRI as the Distributed Information Centre for the Eastern Ghats region of India. EIC Collaborates with the Stockholm Environment Institute Sweden Database on Economics of Industrial Pollution Prevention in India Database of Large and Medium Scale Industries of Andhra Pradesh Environmental Status of the Hyderabad Urban Agglomeration Study on 'water pollution-health linkages' for a few Districts of A.P</li> </ul>



		<ul style="list-style-type: none"> <li>⊙ Environment Quality Mapping <ul style="list-style-type: none"> <li>Macro level studies for six districts in the State of Andhra Pradesh</li> <li>Micro level studies for two study zones presenting the permissible pollutant load and scoping for new industrial categories</li> <li>Zonation of the IDA, Parwada which helped APIIC to promote the land for industrial development</li> <li>Disaster management plan for Visakhapatnam Industrial Bowl Area</li> </ul> </li> </ul>
15.	<p>Forest Survey of India (FSI) Kaulagarh Road, P.O., IPE Dehradun - 248 195 Tel# 0135-756139, 755037, 754507 Fax # 91-135-759104 E-Mail : <a href="mailto:fsidir@nde.vsnl.net.in">fsidir@nde.vsnl.net.in</a> <a href="mailto:fsihq@nde.vsnl.net.in">fsihq@nde.vsnl.net.in</a></p> <p>RO- Banglore, Calcutta, Nagpur and Shimla</p>	<ul style="list-style-type: none"> <li>⊙ State of Forest Report (Biannual)</li> <li>⊙ National Forest Vegetation Map (Biannual exercise) (on 1: 1 million scale)</li> <li>⊙ Thematic mapping on 1:50,000 scale depicting the forest type, species composition, crown density of forest cover and other landuse National</li> <li>⊙ Basic Forest Inventory System</li> <li>⊙ Inventory survey of non forest area</li> <li>⊙ Forest inventory report providing details of area estimates, topographic description, health of forest, ownership pattern, estimation of volume and other growth parameters such as height and diameter in different types of forest, estimation of growth, regeneration and mortality of important species, volume equation and wood consumption of the area studied</li> </ul>
16.	<p>Geological Survey of India 27 Jawaharlal Nehru Road, Calcutta 700 016, India Telephone +91-33- 2496941 FAX 91-33-2496956 <a href="mailto:gsi_chq@vsnl.com">gsi_chq@vsnl.com</a></p>	<ul style="list-style-type: none"> <li>⊙ Environmental hazards zonation mapping in mineral sector</li> <li>⊙ Codification of base line information of geo-environmental appreciation of any terrain and related EIA and EMP studies</li> <li>⊙ Lineament and geomorphological map of India on 1:20,000 scale.</li> <li>⊙ Photo-interpreted geological and structural maps of terrains with limited field checks.</li> </ul>
17.	<p>Indian Council of Agriculture Research, Krishi Bhawan, New Delhi, Tel#011-338206</p> <ul style="list-style-type: none"> <li>- ICAR complex, Goa- Agro metrology</li> <li>- Central Arid Zone Research Institute- Agro forestry</li> <li>- Central Soil salinity Research Institute,</li> <li>- Indian Institute of Soil Science</li> <li>- Central Soil and Water Conservation Research and Training Institute</li> <li>- National Bureau of Soil Survey and Landuse Planning</li> </ul>	<ul style="list-style-type: none"> <li>⊙ A total of 80,000 profiles at 10 kms grid across the country were analyzed to characterize the soils of India.</li> <li>⊙ Detailed soil maps of the Country (1:7 million), State (1:250,000) and districts map (1:50,000) depicting extent of degradation (1:4.4 millions) have been prepared.</li> <li>⊙ Thematic maps depicting soil depth, texture drainage, calcareousness, salinity, pH, slope and erosion have been published</li> <li>⊙ Agro-climate characterization of the country based on moisture, thermal and sunshine regimes</li> <li>⊙ Agro-ecological zones (20) and sub-zones (60) for the country were delineated based on physiography, soils, climate, Length of Growing Period and Available Water Content, and mapped on 1:4.4 million scale.</li> <li>⊙ Digitization of physiography and soil resource base on 1:50,000 scale for 14 States have been completed.</li> <li>⊙ .Soil fertility maps of N,P,K,S and Zn have also been developed</li> <li>⊙ Water quality guidelines for irrigation and naturally occurring saline/sodic water</li> <li>⊙ Calibration and verification of ground water models for predicting water logging and salinity hazards in irrigation commands</li> </ul>
18.	<p>Indian Bureau of Mines Indira Bhawan, Civil Lines Nagpur Ph no - 0712-533 631, Fax- 0712-533 041</p>	<ul style="list-style-type: none"> <li>⊙ National mineral inventory for 61 minerals and mineral maps</li> <li>⊙ Studies on environmental protection and pollution control in regard to the mining and mineral beneficiation operations</li> <li>⊙ Collection, processing and storage of data on mines, minerals and mineral-based industries, collection and maintenance of world mineral intelligence, foreign mineral legislation and other related matters</li> </ul>

19.	Indian Meteorology Department Shivaji nagar, Pune 41100  RO- Mumbai, Chennai, Calcutta, New Delhi, Nagpur, Guwahati	<ul style="list-style-type: none"> <li>⊙ Meteorological data</li> <li>⊙ Background air quality monitoring network under Global Atmospheric Watch Programme (operates 10 stations)</li> <li>⊙ Seismicity map, seismic zoning map; seismic occurrences and cyclone hazard monitoring; list of major earthquakes</li> <li>⊙ Climatological Atlas of India , Rainfall Atlas of India and Agroclimatic Atlas of India</li> <li>⊙ Monthly bulletin of Climate Diagnostic Bulletin of India</li> <li>⊙ Environmental Meteorological Unit of IMD at Delhi to provide specific services to MoEF</li> </ul>
20.	INTACH Natural Heritage, 71 Lodi Estate, New Delhi-110 003 Tel. 91-11-4645482, 4632267/9, 4631818, 4692774, 4641304 Fax : 91- 11-4611290 E-mail : <a href="mailto:nh@intach.net">nh@intach.net</a>	<ul style="list-style-type: none"> <li>⊙ Listing and documentation of heritage sites identified by municipalities and local bodies (Listing excludes sites and buildings under the purview of the Archaeological Survey of India and the State Departments of Archaeology)</li> </ul>
21.	Industrial Toxicology Research Centre Post Box No. 80, Mahatma Gandhi Marg, Lucknow-226001, Phone: +91-522- 221856,213618,228227; Fax : +91- 522 228227 Email: <a href="mailto:itrc@itrcindia.org">itrc@itrcindia.org</a>	<ul style="list-style-type: none"> <li>⊙ Activities include health survey on occupational diseases in industrial workers, air and water quality monitoring studies, ecotoxicological impact assessment, toxicity of chemicals, human health risk assessment</li> <li>⊙ Five databases on CD-ROM in the area of environmental toxicology viz: TOXLINE, CHEMBANK, POISINDEX, POLTOX and PESTBANK. The Toxicology Information Centre provides information on toxic chemicals including household chemicals</li> <li>⊙ ENVIS centre and created a full-fledged computerized database (DABTOC) on toxicity profiles of about 450 chemicals</li> </ul>
22.	Indian Institute of Forest Management Post Box No. 357, Nehru Nagar Bhopal - 462 003 Phone # 0755-575716, 573799, 765125, 767851 Fax # 0755-572878	<ul style="list-style-type: none"> <li>⊙ Consultancy and research on joint forest management (Ford Foundation, SIDA, GTZ, FAO etc)</li> </ul>
23.	Indian Institute of Petroleum Mohkampur , Dehradun, India, 248005 0135- 660113 to 116 0135- 671986	<ul style="list-style-type: none"> <li>⊙ Fuel quality characterisation</li> <li>⊙ Emission factors</li> </ul>
24.	Ministry of Environment and Forest	<ul style="list-style-type: none"> <li>⊙ Survey of natural resources</li> <li>⊙ National river conservation directorate</li> <li>⊙ Environmental research programme for eastern and western ghats</li> <li>⊙ National natural resource management system</li> <li>⊙ Wetlands conservation programme- survey, demarcation, mapping landscape planning, hydrology for 20 identified wetlands National wasteland identification programme</li> </ul>
25.	Mumbai Metropolitan Regional Development Authority	<ul style="list-style-type: none"> <li>⊙ Mumbai Urban Transport Project</li> <li>⊙ Mumbai Urban Development Project</li> <li>⊙ Mumbai Urban Rehabilitation Project</li> <li>⊙ Information on MMR; statistics on councils and corporations Regional Information Centre- Basic data on population, employment, industries and other sectors are regularly collected and processed</li> </ul>

26.	Municipal Corporation of Greater Mumbai	<ul style="list-style-type: none"> <li>⊙ Air Quality Data for Mumbai Municipal Area</li> <li>⊙ Water quality of lakes used for water supply to Mumbai</li> </ul>
27.	Ministry of Urban Development Disaster Mitigation and Vulnerability Atlas of India  Building Materials & Technology Promotion Council G-Wing, Nirman Bhavan, New Delhi-110011 Tel: 91-11-3019367 Fax: 91-11-3010145 E-Mail: bmtpc@del2.vsnl.net.in	<ul style="list-style-type: none"> <li>⊙ Identification of hazard prone area</li> <li>⊙ Vulnerability Atlas showing areas vulnerable to natural disasters</li> <li>⊙ Land-use zoning and design guidelines for improving hazard resistant construction of buildings and housing</li> <li>⊙ State wise hazard maps (on cyclone, floods and earthquakes)</li> </ul>
28.	Natural Disaster Management Division in Department of Agriculture and Cooperation	<ul style="list-style-type: none"> <li>⊙ Weekly situation reports on recent disasters, reports on droughts, floods, cyclones and earthquakes</li> </ul>
29.	National Bureau Of Soil Survey & Land Use Planning P.O. Box No. 426, Shankar Nagar P.O., Nagpur-440010 Tel#91-712-534664,532438,534545 Fax#:91-712-522534  RO- Nagpur, New Delhi, Bangalore, Calcutta, Jorhat, Udaipur	<ul style="list-style-type: none"> <li>⊙ NBSS&amp;LUP Library has been identified as sub centre of ARIC (ICAR) for input to AGRIS covering soil science literature generated in India</li> <li>⊙ Research in weathering and soil formation, soil morphology, soil mineralogy, physicochemical characterisation, pedogenesis, and landscape-climate-soil relationship.</li> <li>⊙ Soil Series of India- The soils are classified as per Soil Taxonomy. The described soil series now belong to 17 States of the country.</li> <li>⊙ Landuse planning- watershed management, land evaluation criteria, crop efficiency zoning</li> <li>⊙ Soil Information system is developed state-wise at 1:250,000 scale. Presently the soil maps of all the States are digitized, processed and designed for final output both digital and hardcopy. The thematic layers and interpreted layers of land evaluation (land capability, land irrigability and crop suitability), Agro-Ecological Zones and soil degradation themes are prepared.</li> <li>⊙ Districts level information system is developed for about 15 districts at 1: 50, 000 scale. The soil information will be at soil series level in this system. Soil resource inventory of States, districts water-sheds (1:250,000; 1:50,000; 1:10,000/8000)</li> </ul>
30.	National Institute of Ocean Technology, Velacherry-Tambaram main road Narayanapuram Chennai, Tamil Nadu Tel#91-44-2460063 / 2460064/ 2460066/ 2460067 Fax#91-44-2460645	<ul style="list-style-type: none"> <li>⊙ Waste load allocation in selected estuaries (Tapi estuary and Ennore creek) is one the components under the Integrated Coastal and Marine Area Management (ICMAM) programme of the Department of Ocean Development ICMAM is conducted with an IDA based credit to the Government of India under the Environmental Capacity Building project of MoEF (waste assimilation capacity of Ennore creek is over)</li> <li>⊙ Physical oceanographic component of Coastal &amp; Ocean monitoring Predictive System (COMAPS) a long term monitoring program under the Department of Ocean Development</li> <li>⊙ Identification of suitable locations for disposal of dredge spoil using mathematical models &amp; environmental criteria</li> <li>⊙ EIA Manual and EIA guidelines for port and harbour projects</li> </ul>
31.	National Institute of Oceanography, Goa  RO- Mumbai, Kochi	<ul style="list-style-type: none"> <li>⊙ Coastal Ocean Monitoring and Predictions(COMAP)-Monitoring of coastal waters for physicochemical and biological parameters including petroleum hydrocarbons, trace metals, heavy metals, and biomass of primary (phytoplankton) and secondary (zooplankton, microbial and benthic organisms)</li> <li>⊙ Marine Biodiversity of selected ecosystem along the West Coast of India</li> </ul>

32.	National Botanical Research Institute, Post Box No 436 Rana Pratap Marg Lucknow- 226001, Tel: (+91) 522 271031-35 Fax: (+91) 522 282849, 282881 Lucknow	<ul style="list-style-type: none"> <li>⊗ Dust filtering potential of common avenue trees and roadside shrubs has been determined, besides studies have also been conducted on heavy-metals accumulation potential of aquatic plants supposedly useful as indicators of heavy metal pollution in water bodies and capable of reducing the toxic metals from water bodies.</li> <li>⊗ Assessment of bio-diversity of various regions of India</li> </ul>
33.	National Geophysical Research Institute, Uppal Road, Hyderabad Telephone:0091-40-7171124, FAX:0091-40-7171564	<ul style="list-style-type: none"> <li>⊗ Exploration, assessment and management of ground water resources including ground water modelling and pollution studies</li> </ul>
34.	National Environmental Engineering Research Institute, Nagpur RO- Mumbai, Delhi, Chennai, Calcutta, Ahmedabad, Cochin, Hyderabad, Kanpur	<ul style="list-style-type: none"> <li>⊗ National Air Quality Monitoring (NAQM) for CPCB</li> <li>⊗ Database on cleaner technologies of industrial productions</li> </ul>
35.	National Hydrology Institute, Roorkee RO- Belgaum (Hard Rock Regional Centre), Jammu (Western Himalayan Regional Centre), Guwahati (North Eastern Regional Centre), Kakinada (Deltaic Regional Centre), Patna (Ganga Plains North Regional Centre), and Sagar (Ganga Plains South)	<ul style="list-style-type: none"> <li>⊗ Basin studies, hydrometeorological network improvement, hydrological year book, hydrological modelling, regional flood formulae, reservoir sedimentation studies, environmental hydrology, watershed development studies, tank studies, and drought studies.</li> </ul>
36.	National Institute Of Urban Affairs, India Habitat Centre, New Delhi	<ul style="list-style-type: none"> <li>⊗ Urban Statistics Handbook</li> </ul>
37.	National Institute of Occupational Health Meghaninagar, Ahmedabad  RO- Banglore, Calcutta	<ul style="list-style-type: none"> <li>⊗ epidemiological studies and surveillance of hazardous occupations including air pollution, noise pollution, agricultural hazards, industrial hazards in organised sectors as well as small scale industries, carcinogenesis, pesticide toxicology, etc</li> <li>⊗ WHO collaborative centre for occupational health for South East Asia region and the lead institute for the international programme on chemical safety under IPCS (WHO)</li> </ul>
38.	NRSA Data Centre Department of Space, Balanagar, Hyderabad 500 037 Ph- 040-3078560 3078664 <a href="mailto:sales@nrsa.gov.in">sales@nrsa.gov.in</a>	<ul style="list-style-type: none"> <li>⊗ Satellite data products (raw data, partially processed (radiometrically corrected but geometrically uncorrected), standard data (radiometrically and geometrically corrected), geocoded data(1:50,000 and 1:25000 scale), special data products like mosaiced, merged and extracted) available on photographic (B&amp;W and FCC in form of film of 240 mm X 240mm or enlargements/paper prints in scale varying between 1:1M and 1:12500 and size varying between 240mm and 1000mm) and digital media (CD-ROMs, 8 mm tapes)</li> </ul>
39.	Rajiv Gandhi National Drinking Water Mission	<ul style="list-style-type: none"> <li>⊗ Database for groundwater using remote sensing technology (Regional Remote Sensing Service Centre involved in generation of ground water prospect maps at 1:50,000 scale for the State of Kerala, Karnataka, AP, MP and Rajasthan for RGNDWM)</li> </ul>
40.	Space Application Centre Value Added Services Cell (VASC) Remote Sensing Application Area Ahmedabad 380 053 079-676 1188	<ul style="list-style-type: none"> <li>⊗ National Natural Resource Information System</li> <li>⊗ Landuse mapping for coastal regulation zone (construction setback line) upto 1:12500 scale</li> <li>⊗ Inventory of coastal wetlands, coral reefs, mangroves, seaweeds</li> <li>⊗ Monitoring and condition assessment of protected coastal areas</li> </ul>

	Fax- 079-6762735	<ul style="list-style-type: none"> <li>⊗ Wetland mapping and inventory</li> <li>⊗ Mapping of potential hotspots and zoning of environmental hazards</li> <li>⊗ General geological and geomorphological mapping in diverse terrain</li> <li>⊗ Landslide risk zonation for Tehre area</li> </ul>
41.	State Pollution Control Board	<ul style="list-style-type: none"> <li>⊗ State Air Quality Monitoring Programme</li> <li>⊗ Inventory of polluting industries</li> <li>⊗ Identification and authorization of hazardous waste generating industries</li> <li>⊗ Inventory of biomedical waste generating industries</li> <li>⊗ Water quality monitoring of water bodies receiving wastewater discharges</li> <li>⊗ Inventory of air polluting industries</li> <li>⊗ Industrial air pollution monitoring</li> <li>⊗ Air consent, water consent, authorization, environment monitoring reports</li> </ul>
42.	State Ground Water Board	
43.	Survey of India	<ul style="list-style-type: none"> <li>⊗ Topographical surveys on 1:250,000 scales, 1:50,000 and 1:25,000 scales</li> <li>⊗ Digital Cartographical Data Base of topographical maps on scales 1:250,000 and 1:50,000</li> <li>⊗ Data generation and its processing for redefinition of Indian Geodetic Datum</li> <li>⊗ Maintenance of National Tidal Data Centre and receiving/ processing of tidal data of various ports.</li> <li>⊗ Coastal mapping along the Eastern coast line has been in progress to study the effect of submergence due to rise in sea-level and other natural phenomenon. Ground surveys have been completed for the proposed coastal region and maps are under printing.</li> <li>⊗ District planning maps containing thematic information (135 maps) have been printed out of 249 maps covering half the districts of India. Districts planning maps for remaining half of the area are being processed by National Atlas and Thematic Mapping Organisation (NATMO)</li> </ul>
44.	Town and Country Planning Organisation	<ul style="list-style-type: none"> <li>⊗ Urban mapping - Thematic maps and graphic database on towns (under progress in association with NRSA and State town planning department)</li> </ul>
45.	Wildlife Institute of India Post Bag No. 18, Chandrabani Dehradun - 248 001, Uttaranchal Tel#0135 640111 -15, Fax#0135 640117 email : wii@wii .	<ul style="list-style-type: none"> <li>⊗ Provide information and advice on specific wildlife management problems.</li> <li>⊗ National Wildlife Database</li> </ul>
46.	Zoological Survey of India Prani Vigyan Bhawan 'M' Block, New Alipore Calcutta - 700 053 Phone # 91-33-4786893, 4783383 Fax # 91-33-786893 RO - Shillong, Pune, Dehradun, Jabalpur, Jodhpur, Chennai, Patna, Hyderabad, Canning, Behrampur, Kozikode, Itanagar, Digha, Port Blair, Solan	<ul style="list-style-type: none"> <li>⊗ Red Book for listing of endemic species</li> <li>⊗ Survey of faunal resources</li> </ul>

---

**ANNEXURE X**  
**Impact Prediction Tools**

---

**Table 1: Choice of Models for Impact Prediction: Air Environment \***

MODEL	APPLICATION	REMARKS	REMARKS FOR DISTILLERY PLANTS APPLICATIONS
ISCST 3	<p>Appropriate for point, area and line sources</p> <p>Application for flat or rolling terrain</p> <p>Transport distance up to 50 km valid</p> <p>Computes for 1 hr to annual averaging periods</p>	<p>Can take up to 99 sources</p> <p>Computes concentration on 600 receptors in Cartesian on polar coordinate system</p> <p>Can take receptor elevation</p> <p>Requires source data, meteorological and receptor data as input.</p>	<p>ISCST3 is appropriate for distillery unit located in both simple terrain, where the terrain features are all lower in elevation than the top of the stack of the source, and in complex terrain, where terrain elevations rise to heights above the stack top.</p> <p>The meteorological data required to run ISCST3 includes mixing heights, wind direction, wind velocity, temperature, atmospheric stability and anemometer height.</p>
AERMOD with AERMET	<p>Settling and dry deposition of particles;</p> <p>Building wake effects (excluding cavity region impacts);</p> <p>Point, area, line, and volume sources;</p> <p>Plume rise as a function of downwind distance;</p> <p>Multiple point, area, line, or volume sources;</p> <p>Limited terrain adjustment;</p> <p>Long-term and short-term averaging modes;</p> <p>Rural or urban modes;</p> <p>Variable receptor grid density; and</p> <p>Actual hourly meteorology data</p>	<p>Can take up to 99 sources</p> <p>Computes concentration on 600 receptors in Cartesian on polar coordinate system</p> <p>Can take receptor elevation</p> <p>Requires source data, meteorological and receptor data as input.</p>	<p>AERMOD, is a state-of-art and steady-state plume dispersion model for assessment of pollutant concentrations from a variety of sources. AERMOD simulates transport and dispersion from multiple points, area, or volume sources based on an up-to-date characterization of the atmospheric boundary layer. Sources may be located in rural or urban areas, and receptors may be located in simple or complex terrain. AERMOD accounts for building near-wake and far-wake effects (i.e., plume downwash) using the PRIME wake effect model. The AERMOD model employs hourly sequential meteorological data to estimate concentrations for averaging times ranging from one hour to one year.</p> <p>The AERMET module is the</p>

MODEL	APPLICATION	REMARKS	REMARKS FOR DISTILLERY PLANTS APPLICATIONS
			<p>meteorological preprocessor for the AERMOD program. Output includes surface meteorological observations and parameters and vertical profiles of several atmospheric parameters. AERMET is a general purpose meteorological preprocessor for organizing available meteorological data into a format suitable for use by the AERMOD air quality dispersion model</p>
PTMAX	<p>Screening model applicable for a single point source  Computes maximum concentration and distance of maximum concentration occurrence as a function of wind speed and stability class</p>	<p>Require source characteristics  No met data required  Used mainly for ambient air monitoring network design</p>	
PTDIS	<p>Screening model applicable for a single point source  Computes maximum pollutant concentration and its occurrences for the prevailing meteorological conditions</p>	<p>Require source characteristics  Average met data (wind speed, temperature, stability class etc.) required  Used mainly to see likely impact of a single source</p>	
MPTER	<p>Appropriate for point, area and line sources applicable for flat or rolling terrain  Transport distance up to 50 km valid  Computes for 1 hr to annual averaging periods  Terrain adjustment is possible</p>	<p>Can take 250 sources  Computes concentration at 180 receptors up to 10 km  Requires source data, meteorological data and receptor coordinates</p>	



MODEL	APPLICATION	REMARKS	REMARKS FOR DISTILLERY PLANTS APPLICATIONS
CTDM PLUS (Complex Terrain Dispersion Model)	Point source steady state model, can estimate hrly average concentration in isolated hills/ array of hills	<p>Can take maximum 40 Stacks and computes concentration at maximum 400 receptors</p> <p>Does not simulate calm met conditions</p> <p>Hill slopes are assumed not to exceed 15 degrees</p> <p>Requires sources, met and terrain characteristics and receptor details</p>	
UAM (Urban Airshed Model)	<p>3-D grid type numerical simulation model</p> <p>Computes O<sub>3</sub> concentration short term episodic conditions lasting for 1 or 2 days resulting from NO<sub>x</sub> and VOCs</p> <p>Appropriate for single urban area having significant O<sub>3</sub> problems</p>		
RAM (Rural Airshed Model)	<p>Steady state Gaussian plume model for computing concentration of relatively stable pollutants for 1 hr to 1 day averaging time</p> <p>Application for point and area sources in rural and urban setting</p>	<p>Suitable for flat terrains</p> <p>Transport distance less than 50 km.</p>	
CRESTER	<p>Applicable for single point source either in rural or urban setting</p> <p>Computes highest and second highest concentration for 1hr, 3hr, 24hr and annual averaging times</p> <p>Tabulates 50 highest concentration for entire year for each averaging times</p>	<p>Can take up to 19 Stacks simultaneously at a common site.</p> <p>Unsuitable for cool and high velocity emissions</p> <p>Do not account for tall buildings or topographic features</p> <p>Computes concentration at 180 receptor, circular wing at five downwind ring distance 36 radials</p>	

MODEL	APPLICATION	REMARKS	REMARKS FOR DISTILLERY PLANTS APPLICATIONS
		Require sources, and met data	
OCD (Offshore and coastal Dispersion Model)	<p>It determines the impact of offshore emissions from point sources on the air quality of coastal regions</p> <p>It incorporates overwater plume transport and dispersion as well as changes that occur as the plume crosses the shore line</p> <p>Most suitable for overwater sources shore onshore receptors are below the lowest shore height</p>	<p>Requires source emission data</p> <p>Require hrly met data at offshore and onshore locations like water surface temperature; overwater air temperature; relative humidity etc.</p>	
FDM (Fugitive Dust Model)	<p>Suitable for emissions from fugitive dust sources</p> <p>Source may be point, area or line (up to 121 source)</p> <p>Require particle size classification max. up to 20 sizes</p> <p>Computes concentrations for 1 hr, 3hr, 8hr, 24hr or annual average periods</p>	<p>Require dust source particle sizes</p> <p>Source coordinates for area sources, source height and geographic details</p> <p>Can compute concentration at max. 1200 receptors</p> <p>Require met data (wind direction, speed, Temperature, mixing height and stability class)</p> <p>Model do not include buoyant point sources, hence no plume rise algorithm</p>	
RTDM (Rough Terrain Diffusion Model)	<p>Estimates GLC is complex/rough (or flat) terrain in the vicinity of one or more co-located point sources</p> <p>Transport distance max. up to 15 km to up to 50 km</p> <p>Computes for 1 to 24 hr. or annual average</p>	<p>Can take up to 35 co-located point sources</p> <p>Require source data and hourly met data</p> <p>Computes concentration at maximum 400 receptors</p> <p>Suitable only for non reactive gases</p> <p>Do not include gravitational effects or depletion</p>	

MODEL	APPLICATION	REMARKS	REMARKS FOR DISTILLERY PLANTS APPLICATIONS
	concentrations	mechanism such as rain/ wash out, dry deposition	
CDM (Climatologic ally Dispersion Model)	It is a climatologically steady state GPM for determining long term (seasonal or annual) Arithmetic average pollutant concentration at any ground level receptor in an urban area	Suitable for point and area sources in urban region, flat terrain Valid for transport distance less than 50 km Long term averages: One month to one year or longer	
PLUVUE-II (Plume Visibility Model)	Applicable to assess visibility impairment due to pollutants emitted from well defined point sources It is used to calculate visual range reduction and atmospheric discoloration caused by plumes It predicts transport, atmospheric diffusion, chemical, conversion, optical effects, and surface deposition of point source emissions.	Require source characteristics, met data and receptor coordinates & elevation Require atmospheric aerosols (back ground & emitted) characteristics, like density, particle size Require background pollutant concentration of SO <sub>4</sub> , NO <sub>3</sub> , NO <sub>x</sub> , NO <sub>2</sub> , O <sub>3</sub> , SO <sub>2</sub> and deposition velocities of SO <sub>2</sub> , NO <sub>2</sub> and aerosols	
MESO-PUFF II (Meso scale Puff Model)	It is a Gaussian, Variable trajectory, puff superposition model designed to account fro spatial and temporal variations in transport, diffusion, chemical transformation and removal mechanism encountered on regional scale. Plume is modeled as a series of discrete puffs and each puff is transported independently Appropriate for point	Can model five pollutants simultaneously (SO <sub>2</sub> , SO <sub>4</sub> , NO <sub>x</sub> , HNO <sub>3</sub> and NO <sub>3</sub> ) Require source characteristics Can take 20 point sources or 5 area source For area source – location, effective height, initial puff size, emission is required Computes pollutant concentration at max. 180 discrete receptors and 1600 (40 x 40) grided receptors Require hourly surface data including cloud cover and	

<b>MODEL</b>	<b>APPLICATION</b>	<b>REMARKS</b>	<b>REMARKS FOR DISTILLERY PLANTS APPLICATIONS</b>
	and area sources in urban areas Regional scale model.	twice a day upper air data (pressure, temp, height, wind speed, direction) Do not include gravitational effects or depletion mechanism such as rain/wash out, dry deposition	

**Table 2: Choice of Models for Impact Modeling: Noise Environment \***

<b>Model</b>	<b>Application</b>
FHWA (Federal Highway Administration)	Noise Impact due to vehicular movement on highways
Dhwani	For predictions of impact due to group of noise sources in the industrial complex (multiple sound sources)
Hemispherical sound wave propagation Air Port	Fore predictive impact due to single noise source For predictive impact of traffic on airport and rail road

**Table 3: Choice of Methods for Impact Modeling: Land Environment \***

<b>Model</b>	<b>Application</b>	<b>Remarks</b>
Digital Analysis Techniques	Provides land use / land cover distribution	
Ranking analysis for soil suitability criteria	Provides suitability criteria for developmental conversation activities	Various parameters viz. depth, texture, slope, erosion status, geomorphology, flooding hazards, GW potential, land use etc. are used.

**Table 4: Choice of Models for Impact Modeling: Water Environment \***

<b>Model</b>	<b>Application</b>	<b>Remarks</b>
QUAL-II E	Wind effect is insignificant, vertical dispersive effects insignificant applicable to streams Data required Deoxygenation coefficients, re-aeration coefficients for carbonaceous, nitrogenous and benthic substances, dissolved oxygen deficit	Steady state or dynamic model
	The model is found excellent to generate water quality parameters Photosynthetic and respiration rate of suspended and attached algae	
	Parameters measured up to 15 component can be simulated in any combination, e.g. ammonia, nitrite, nitrate, phosphorous, carbonaceous BOD, benthic oxygen demand, DO, coliforms, conservative substances and temperature	
DOSAG-3, USEPA: (1-D) RECEIV – II, USEPA	Water quality simulation model for streams & canal A general Water quality model	Steady-state
Explore –I, USEPA	A river basin water quality model	Dynamic, Simple hydrodynamics
HSPE, USEPA	Hydrologic simulation model	Dynamic, Simple hydrodynamics
RECEIVE-II, USEPA	A general dynamic planning model for water quality management	
Stanford watershed model	This model simulates stream flows once historic precipitation data are supplied The major components of the hydrologic cycle are modeled including interception, surface detention, overland inflow, groundwater, evapo-transpiration and routing of channel flows, temperature, TDS, DO, carbonaceous BOD coliforms, algae, zooplanktons, nitrite, nitrate, ammonia, phosphate and conservative substances can be simulated	
Hydrocomp model	Long-term meteorological and wastewater characterization data is used to simulate stream flows and stream water quality	Time dependant (Dynamic)
Stormwater Management model	Runoff is modeled from overland flow, through surface channels, and through sewer network Both combined and separate sewers can be	Time Dependent

<b>Model</b>	<b>Application</b>	<b>Remarks</b>
(SWMM)	modeled. This model also enables to simulate water quality effects to stormwater or combined sewer discharges. This model simulates runoff resulting from individual rainfall events.	
Battelle Reservoir model	Water body is divided into segments along the direction of the flow and each segment is divided into number of horizontal layers. The model is found to generate excellent simulation of temperature and good prediction of water quality parameters. The model simulates temperature, DO, total and benthic BOD, phytoplankton, zooplankton, organic and inorganic nitrogen, phosphorous, coliform bacteria, toxic substances and hydrodynamic conditions.	Two Dimensional multi-segment model
TIDEP (Turbulent diffusion temperature model reservoirs)	Horizontal temperature homogeneity Coefficient of vertical turbulent diffusion constant for charge of area with depth negligible coefficient of thermal exchange constant Data required wind speed, air temperature, air humidity, net incoming radiation, surface water temperature, heat exchange coefficients and vertical turbulent diffusion coefficients.	Steady state model
BIOLAKE	Model estimates potential fish harvest from a take	Steady state model
Estuary models/ estuarial Dynamic model	It is simulates tides, currents, and discharge in shallow, vertically mixed estuaries excited by ocean tides, hydrologic influx, and wind action Tides, currents in estuary are simulated	Dynamic model
Dynamic Water Quality Model	It simulates the mass transport of either conservative or non-conservative quality constituents utilizing information derived from the hydrodynamic model Bay-Delta model is the programme generally used. Up to 10 independent quality parameters of either conservative or non-conservative type plus the BOD-DO coupled relationship can be handled	Dynamic model
HEC -2	To compute water surface profiles for steady, gradually: varying flow in both prismatic & non- prismatic channels	
SMS	Lake circulation, salt water intrusion, surface water profile simulation model	Surface water Modeling system

Model	Application	Remarks
		Hydrodynamic model
RMA2	To compute flow velocities and water surface elevations	Hydrodynamic analysis model
RMA4	Solves advective-diffusion equations to model up to six non-interacting constituents	Constituent transport model
SED2D-WES	Model simulates transport of sediment	Sediment transport model
HIVEL2D	Model supports subcritical and supercritical flow analysis	A 2-dimensional hydrodynamic model
MIKE-II, DHI	Model supports, simulations of flows, water quality, and sediment transport in estuaries, rives, irrigation systems, channels & other water bodies	Professional Engineering software package

**Table 5: Choice of Methods for Impact Modeling: Biological Environment \***

Name	Relevance	Applications	Remarks
<b>Flora</b>			
Sample plot methods	Density and relative density Density and relative dominance	Average number of individuals species per unit area Relative degree to which a species predominates a community by its sheer numbers, size bulk or biomass	The quadrant sampling technique is applicable in all types of plant communities and for the study of submerged, sessile (attached at the base) or sedentary plants
	Frequency and relative frequency importance value	Plant dispersion over an area or within a community	Commonly accepted plot size: 0.1 m <sup>2</sup> - mosses, lichens & other mat-like plants
		Average of relative density, relative dominance and relative frequency	0.1 m <sup>2</sup> - herbaceous vegetation including grasses
			10.20 m <sup>2</sup> – for shrubs and saplings up to 3m tall, and
			100 m <sup>2</sup> – for tree communities
Transects & line intercepts methods	Cover	Ratio of total amount of line intercepted by each species and total length of the line intercept given	This methods allows for rapid assessment of vegetation transition zones, and requires minimum time or equipment of

Name	Relevance	Applications	Remarks
		its cover	establish
	Relative dominance	It is the ratio of total individuals of a species and total individuals of all species	Two or more vegetation strata can be sampled simultaneously
Plot-less sampling methods	Mean point plant Mean area per plant	Mean point – plant distance Mean area per plant	Vegetation measurements are determined from points rather than being determined in an area with boundaries
	Density and relative density		Method is used in grass-land and open shrub and tree communities
	Dominance and relative dominance		It allows more rapid and extensive sampling than the plot method
	Importance value		Point- quarter method is commonly used in woods and forests.
<b>Fauna</b>			
Species list methods	Animal species list	List of animal communities observed directly	Animal species lists present common and scientific names of the species involved so that the faunal resources of the area are catalogued
Direct Contact Methods	Animal species list	List of animals communities observed directly	This method involves collection, study and release of animals
Count indices methods (Roadside and aerial count methods)	Drive counts Temporal counts	Observation of animals by driving them past trained observers	Count indices provide estimates of animal populations and are obtained from signs, calls or trailside counts or roadside counts
	Call counts	Count of all animals passing a fixed point during some stated interval of time	These estimates, through they do not provide absolute population numbers, Provide an index of the various species in an area
			Such indices allow comparisons through the seasons or between sites or habitats
Removal	Population size	Number of species	Removal methods are used to



Name	Relevance	Applications	Remarks
methods		captured	obtain population estimates of small mammals, such as, rodents through baited snap traps
Market capture methods	Population size estimate (M)	Number of species originally marked (T) Number of marked animals recaptured (t) and total number of animals captured during census (n) $N = nT/t$	It involves capturing a portion of the population and at some later date sampling the ratio of marked to total animals caught in the population

**Table 6: Choice of Methods for Impact Predictions: Socio-economic Aspects \***

Relevance		
Name	Application	Remarks
Extrapolative Methods	A prediction is made that is consistent with past and present socio-economic data, e.g. a prediction based on the linear extrapolation of current trends	
Intuitive Forecasting (Delphi techniques)	Delphi technique is used to determine environmental priorities and also to make intuitive predictions through the process of achieving group consensus	Conjecture Brainstorming Heuristic programming Delphi consensus
Trend extrapolation and correlation	Predictions may be obtained by extrapolating present trends Not an accurate method of making socio-economic forecasts, because a time series cannot be interpreted or extrapolated very far into the future with out some knowledge of the underlying physical, biological, and social factors	Trend breakthrough precursor events correlation and regression
Metaphors and analogies	The experience gained else where is used to predict the socio-economic impacts	Growth historical simulation commonsense forecasts
Scenarios	Scenarios are common-sense forecasts of data. Each scenario is logically constructed on model of a potential future for which the degrees of "confidence" as to progression and outcome remain undefined	Common-sense
Dynamic modeling (Input-Output model)	Model predicts net economic gain to the society after considering all inputs required for conversion of raw materials along with cost of finished product	
Normative Methods	Desired socio-economic goals are specified and an attempt is made to project the social	Morphological analysis technology scanning

<b>Relevance</b>		
<b>Name</b>	<b>Application</b>	<b>Remarks</b>
	environment backward in time to the present to examine whether existing or planned resources and environmental programmes are adequate to meet the goals	contextual mapping - functional array - graphic method Mission networks and functional arrays decision trees & relevance trees matrix methods scenarios

\* **NOTE:** (i) If a project proponent prefer to use any model other than listed, can do so, with prior concurrence of concerned appraisal committee. (ii) Project-specific proposed prediction tools need to be identified by the project proponent and shall be incorporated in the draft ToR to be submitted to the Authority for the consideration and approval by the concerned EAC/SEAC.

---

**ANNEXURE XI**

**Form through which the State Governments/Administration of  
the Union Territories Submit Nominations for SEIAA and SEAC  
for the Consideration and Notification by the  
Central Government**

---

<b>Form for Nomination of a professional/expert as Chairperson / Member / Secretary of the SEIAA / EAC / SEAC</b>						
<b>1 Name (in block letters)</b>						
<b>2 Address for communication</b>						
<b>3 Age &amp; Date of Birth</b> (Shall be less than 67 years for the members and 72 years for the Chairman)						
<b>4 Area of Expertise (As per Appendix VI)</b>						
<b>5</b>	<b>Professional Qualifications (As per Appendix VI)</b>	<b>Qualification(s)</b>	<b>University</b>	<b>Year of passing</b>	<b>Percentage of marks</b>	
<b>6</b>	<b>Work experience</b>  (High light relevant experience as per Appendix VI)	<b>Position</b>	<b>Years of association</b>		<b>Nature of work. If required, attach separate sheets</b>	
			<b>From</b>	<b>to</b>		<b>Period in years</b>
<b>7</b>	<b>Present position and nature of job</b>	Serving Central / State Government Office?			<b>Yes/No</b>	
		Engaged in industry or their associations?			<b>Yes/No</b>	
		Associated with environmental activism?			<b>Yes/No</b>	
		If no is the answer for above three, please specify the present position and name of the organization				
<b>8</b>	<b>Whether experienced in the process of prior environmental clearance?</b>	Yes/No. If yes, please specify the experience in a separate sheet (Please restrict to 500 words)				
<b>9</b>	<b>Whether any out-standing expertise has been acquired?</b>	Yes/ No If yes, please provide details in a separate sheet (Please restrict to 500 words).				
<b>10</b>	<b>Any other relevant information?</b>	May like to attach separate sheets (Research projects, consultancy projects, publications, memberships in associations, trainings undergone, international exposure cum experience etc.)				

The Government of.....is pleased to forward the Nomination of Dr./Sh. .... for the position of Chairperson / Member / Secretary of the SEIAA / SEAC / EAC to the Ministry of Environment & Forests, the Government of India for the Notification.

(Authorized Signature with Seal)

---

**ANNEXURE XII**  
**Composition of EAC/SEAC**

---

## **Composition of the EAC/SEAC**

The Members of the EAC shall be Experts with the requisite expertise and experience in the following fields /disciplines. In the event that persons fulfilling the criteria of “Experts” are not available, Professionals in the same field with sufficient experience may be considered:

- Environment Quality Experts: Experts in measurement/monitoring, analysis and interpretation of data in relation to environmental quality
- Sectoral Experts in Project Management: Experts in Project Management or Management of Process/Operations/Facilities in the relevant sectors.
- Environmental Impact Assessment Process Experts: Experts in conducting and carrying out Environmental Impact Assessments (EIAs) and preparation of Environmental Management Plans (EMPs) and other Management plans and who have wide expertise and knowledge of predictive techniques and tools used in the EIA process
- Risk Assessment Experts
- Life Science Experts in floral and faunal management
- Forestry and Wildlife Experts
- Environmental Economics Expert with experience in project appraisal

---

**ANNEXURE XIII**

**Best Practices & Latest Technologies available and reference**

---

## **Best Practices & Latest Technologies available and reference**

### **Best Available Technologies across entire process:**

- Apply Clean-in-place (CIP) methods for decontaminating equipment.
- Use high-pressure, low-volume hoses for equipment cleaning.
- Use re-circulating systems on cooling water circuits.
- Filtrate bottom sediments from final fermentation tanks for use as animal feed

### **Best Available Technologies for effluent treatment:**

Wherever possible, waste water segregation is recommended. There exists potential for high-volume low-strength streams to be either:

- recycled (following suitable treatment)
- discharged directly to sewer (without treatment)
- mixed with treated final effluent prior to discharge

The options available will be dependent upon the receiving water and hence the consent to discharge. By segregating low-strength streams, a treatment facility can be reduced in size by designing on high strength waste waters released from an installation. Fermentable and non-fermentable wastes are kept separate to maximize potential for re-use.

In general, when applying techniques for the treatment of waste waters released from the brewery sub-sector, the following unit processes may be considered:

- Screening.
- Primary treatment.
- With regard to the pollution strength, aerobic or anaerobic biological techniques are regarded as BAT

### **Best Available Technology for Waste Water Treatment:**

Treatment for discharge to sewer

The level of treatment required prior to discharge to sewer is dependent upon the consent to discharge conditions. An economic balance needs to be achieved taking into account trade effluent charges and the capital and operating costs of a new effluent treatment plant.



The soft drinks and beverages sub-sector is a diverse sector on its own, however, for the purposes of effluent treatment, the waste waters generated can be categorized as follows:

- Low strength high volume
- High strength low volume
- Continuous regular discharges
- Campaign/seasonal discharges.

□ **Screening** to remove gross solids is recommended for installations in this sub-sector. Static wedge screens are cleaned several times a day to remove build-up. Self-cleaning screens are preferable, otherwise regular manual cleaning takes place. Vibrating screens have also been used successfully within this sub-sector.

Due to the batch-wise nature of the processes and wash down regimes, flow and load balancing would be required. The waste water from this sub-sector tends to be highly biodegradable and contain active bio-organisms. Excessive retention in the balance tank are avoided to ensure that the contents do not become anaerobic, leading to acidity and odour. The balance tank is agitated to prevent sludge accumulation, minimizing the potential for methane build-up. A balance tank would typically have a retention time of 6 - 12 hours.

□ High trade effluent charges will make it cost-effective for most installations to carry out some form of **primary treatment**. Dissolved air flotation is widely used in this sub-sector for the removal of fats, oils and greases and of suspended solids. The separated material can generally be re-used as animal feed if suitable coagulants and flocculants have been chosen.

In some instances, discharge to sewer could occur downstream of a primary process, depending upon the efficiency of the process and the receiving sewage treatment works. In this case operators must allow for a contingency strategy for failure of the primary treatment process, e.g. a diversion tank.

□ Following primary treatment, further stages may be required, either to achieve a consent to discharge or to minimize trade effluent charges. For waste water streams with a BOD concentration greater than 1000 - 1500 mg/L BOD **anaerobic treatment** processes are considered. If anaerobic technique is used, operators ensure that fats, oils and greases are not allowed to reach the anaerobic reactor as well as minimizing any biocides from reaching this stage of the process. Final effluent from the anaerobic process could be discharged directly to sewer, following flash aeration.

□ For lower strength waste water streams **aerobic treatment** would be the preferred option. Conventional activated sludge systems have been used for such waste water streams, and (where economics allow) activated sludge variants (pure oxygen, SBR, MBR) would also be applicable. High rate trickling filters have also been employed as well as the standard rate configuration.

Hybrid aerobic reactors, such as the submerged biological aerated filter are also gaining popularity in this field.

For installations affected by seasonal produce, a number of options exist. Installations such as these will have general waste water generated all year round from the continuous production on-site. During the season or campaign, further waste water is generated from intensive processes. The nature of the general waste water and the campaign waste water will dictate the technique for the installation.

Typically the campaign waste water will be higher in strength than the general waste water and a number of factors will affect an operators choice of techniques under these conditions, e.g. the discharge points for the waste water streams may not be close to each other and there may be little or no process benefit in combining the streams.

The main choice facing operators here will be whether to treat the waste water streams separately or together. This will be site-specific and will be dependent upon the nature of the streams, the nature of the streams when combined, and the economics of constructing an effluent treatment plant capable of receiving significantly higher loads during a campaign.

If treated separately, the general waste water stream may require primary treatment only (prior to discharge to sewer), however, secondary treatment requirements would be aerobic biological treatment, typically conventional activated sludge, trickling filters and hybrid reactors, such as the submerged biological aerated filter.

The campaign/seasonal waste water is typically high in strength and comparatively low in volume. As the waste water stream is generated during certain times of the year only, anaerobic treatment would be considered for the treatment of the stream. Final effluent from the anaerobic process could be discharged directly to sewer, following flash aeration.

For treating the streams together, a treatment plant must be of modular construction with two or more reactors working in parallel. This will allow for one reactor to be used out of season with the plant brought up to full capacity during the seasonal production. A technique to consider for this configuration would be a conventional activated sludge process with pure oxygen supplementation during the high loads associated with the seasonal production. The plant may require artificial feeding in preparation for the increased flows and loads.

#### ***Treatment for discharge to water course or for recycling***

For discharges to water courses, or for treating effluent to a quality suitable for re-use, further treatment stages would be required.

□ For high strength waste waters that have already passed through an **anaerobic treatment** plant, a **further aerobic plant** will be generally required. Typically anaerobic reactors are followed by conventional activated sludge systems for further treatment. A two stage biological system (anaerobic followed by aerobic) if designed correctly achieves a quality of effluent suitable for discharge to a water course. Should suspended solids consent be low a tertiary macrofiltration system (sandfilter) would be required.

Further tertiary treatment would be required for recycling all or part of the final effluent. Due to the nature of the waste, GAC filters and/or crossflow microfiltration would be required. Disinfection would also be recommended should recycled water be used in hygienic areas.

**Best Environmental Practices across the entire process:**

- Use of grit, weed seed, and discarded grain as chicken feed.
- Use of spent grain as animal feed, either 80% wet, or dry after evaporation.
- Disposal of wet hops by adding them to the spent grain.
- Disposal of spent hop liquor by mixing with spent grain.
- Use for livestock feed of spent yeast that is not reused.
- Disposal of trub by adding it to spent grain.
- Recovery of spilled beer, adding it to spent grain that is being dried through evaporation

**Sources:**

- An overview of wastewater treatment in distillery industry by Kanimozhi and N. Vasudevan, International Journal of Environmental Engineering, Issue: Volume2, Number1-3/2010, Pages: 159 – 184.
- <http://www.iitb.ac.in/~cep/brochures/2007/dikshit-bro-07.html> ,Lenntech, 2009
- <http://www.lenntech.com/membrane-technology.htm>. Water Treatment Method and Disposal
- <http://www.p2pays.org/ref/09/08972.pdf> , Zero Discharge System for Distilleries



## REFERENCES

### Reference Documents

- **Ministry of Environment and Forest, GoI** - “Environment Impact Assessment Notification” S.O.1533 dated 14th September 2006.
- **Ministry of Environment and Forest, GoI** – “Environment Impact Assessment Notification 2006 – Amendment” S.O. 195 (E) dated 1st December, 2009.
- **Ministry of Environment and Forest, GoI** – Charter on Corporate Responsibility for Environment Protection Action Points for 17 Categories of Industries, CPCB, March 2003.
- **Larry W. Canter**, “Environmental Impact Assessment”, Second Edition, McGraw Hill, University of Oklahoma, 1997.
- **International Association for Impact Assessment** in Cooperation with Institute of Environmental Assessment, UK – “Principles of Environmental Impact Assessment Best Practice, 1996
- **IFC**, “Environmental Health and Safety Guidelines for Sugar manufacturing, Draft, August 2006.
- **Confederation of Indian Industry (CII)** - Case Study: Waste Minimization Practices in Distillery Unit, Sohrabji Green Business Centre.
- **Central Pollution Control Board** - Comprehensive industry Document Fermentation Industries
- **Central Pollution Control Board** - Management of Distillery Wastewater, Resource Recycling Series: RERES/4/2001-2002, September, 2001.
- **Prof.(Dr.) Arvind Kumar**, “Industrial Pollution Problems and Solutions”, Environmental Science Research Unit, Post Graduate Department of Zoology, S.K.M University, Dumka, Jharkhand, Daya Publishing House, Delhi, 2006
- **Ecosmart India Ltd.**, - Report on Secondary Data Collection for Environmental Information Centre, submitted to Ministry of Environment and Forests, 28<sup>th</sup> March 2003

### Referred Websites

- [http://d.wanfangdata.com.cn/NSTLHY\\_NSTL\\_HY10565889.aspx](http://d.wanfangdata.com.cn/NSTLHY_NSTL_HY10565889.aspx)
- <http://envfor.nic.in/divisions/iass/eia.htm>
- <http://kspcb.kar.nic.in/Disp.htm>



- <http://www.distill.com/india.html>
- <http://www.envis.nic.in/>
- <http://www.iaia.org>
- <http://www.scribd.com/doc/7027043/Bio-Gas-From-Distillery-Spent-Wash>
- [www.cpcb.nic.in](http://www.cpcb.nic.in)



**IL&FS Ecosmart Limited**  
**Flat # 408, Saptagiri Towers**  
**Begumpet**  
**Hyderabad – 500 016**  
**Ph: + 91 40 40163016**  
**Fax: + 91 40 40032220**